



Engineering Knowledge Transfer Units to Increase
Student's Employability and Regional Development

Options for a CO₂ reduced Mobility

Introduction Trainer Wolfgang Kriegler, MSC

FOR EDUCATIONAL PURPOSE ONLY



Co-funded by the
Erasmus+ Programme
of the European Union

This project has been funded with support from the European Commission. This publication reflects the views only of the author, and the Commission cannot be held responsible for any use which may be made of the information contained therein.
598710-EPP-1-2018-1-AT-EPPKA2-CBHE-JP

Brief Introduction

Wolfgang Kriegler MSC



- Study of “Mechanical Engineering”, TU Vienna Austria (1974-1979)
Focus on Internal Combustion Engines and Steam Generators
- Professional Career
 - **AVL Prof. List GesmbH, (1980-2007):**
 - Combustion research Dept. (1 Cyl. FoMo up to truck engines)
 - Test bed developments (dyn. powertrain test bed)
 - Automated ICE calibration methodology
 - Dept. Leader „System-Integration“ (incl. hybrids, vehicle simulation)
 - Core team leader Project House for a Scandinavian truck manufacturer
 - Program & Project-leader for development of a chin. truck engine family
 - **Magna Steyr (2007-)**
 - Product manager Hybrid & EV
 - Leader Hybrid Powertrain in PH MagnaSteyr/Powertrain/Electronics
 - Director Advanced Development & Innovation Management
 - Public Funding, R&D Coordination
 - **FH Joanneum (1997-)**
 - Avocational lecturer alternative powertrains (Hybrid & EV), Piston engines & ICE
 - Predominant occupation since 2014
 - **A3PS Austrian Agency for Advanced Propulsion System (2014-2019)**
 - CEO and Chairman of the board



How to react to the global Trends in Automotive Engineering?



- **Internal Combustion Engines I & II (BAC);** Focus on:
 - Efficiency > low CO₂ foot print
 - Low emissions, aftertreatment systems
 - Use of ice in hybridization
- **Electric machines and inverter (BAC)**
 - Synchron. & asynchronous motors
 - Power electronics
- **Advanced drive and propulsion systems (Master)**
 - Electric vehicles
 - Hybrid vehicles
 - Fuel cell / hydrogen vehicles
- **Energy Management and Storage Systems (Master, elective course)**
 - Energy management / control systems in EVs and Hybrids
 - Mechanical storage systems
 - Electro-chemical storage systems (batteries)
 - Charging technology
 - Gaseous storage systems for CNG and hydrogen
- In Planning: **Advanced Driver Assistance Systems/ Automated Driving**
 - Vehicle related equipment and control systems for ADAS & AD



My lessons @ FH-Joanneum

Internal combustion engines II (BA):

- Mixture process, ignition, combustion, emission, aftertreatment

Advanced Drive and Propulsion systems (MA): encyclopedic

- Electric Vehicle
- Hybrid Vehicles
- Fuel Cell Vehicles

Energy Management and Storage Systems (MA):

- Mechanical storage system; EV and Hybrid energy management

Large Engines (MA):

- Ship powertrains (2 Stroke, cross head) , medium speed engines for power plants, gas engines

Project Work (MA):

- Supervising several student project groups



Engineering Knowledge Transfer Units to Increase
Student's Employability and Regional Development

Options for a CO₂ reduced Mobility

Fuel Options for ICE



Co-funded by the
Erasmus+ Programme
of the European Union

This project has been funded with support from the European Commission. This publication reflects the views only of the author, and the Commission cannot be held responsible for any use which may be made of the information contained therein.
598710-EPP-1-2018-1-AT-EPPKA2-CBHE-JP

FOR EDUCATIONAL PURPOSE ONLY

Starting Point – CO₂ Increase & Global Warming



Statement:

The dominance of conventional (internal combustion engine) powertrains has led to the following problems:

- Traffic congestions (Stop & Go)
- **Emissions** problems (CO, Ozone, HC, NO_x, particulates, dust...)
- Global warming / CO₂ increase
- **CO₂ Legislation**
- Fuel prices up and down
- Political & economic dependency from oil producing countries
- Limited oil reserves

Advanced powertrains and alternatives fuels are becoming more important → Upcoming diversification



Co-funded by the
Erasmus+ Programme
of the European Union

Starting Point – CO₂ Increase & Global Warming



Statement:

The dominant problem of conventional (internal combustion engine) vehicles is the following problems:

**Do you agree, we cannot continue!
We need actions!!!**

- Global warming / CO₂ increase
- **CO₂ Legislation**
- Fuel prices up and down
- Political & economic dependency from oil producing countries
- Limited oil reserves

Advanced powertrains and alternatives fuels are becoming more important → Upcoming diversification



Co-funded by the Erasmus+ Programme of the European Union

Increase of CO₂ Emission in the last decades – a closer look

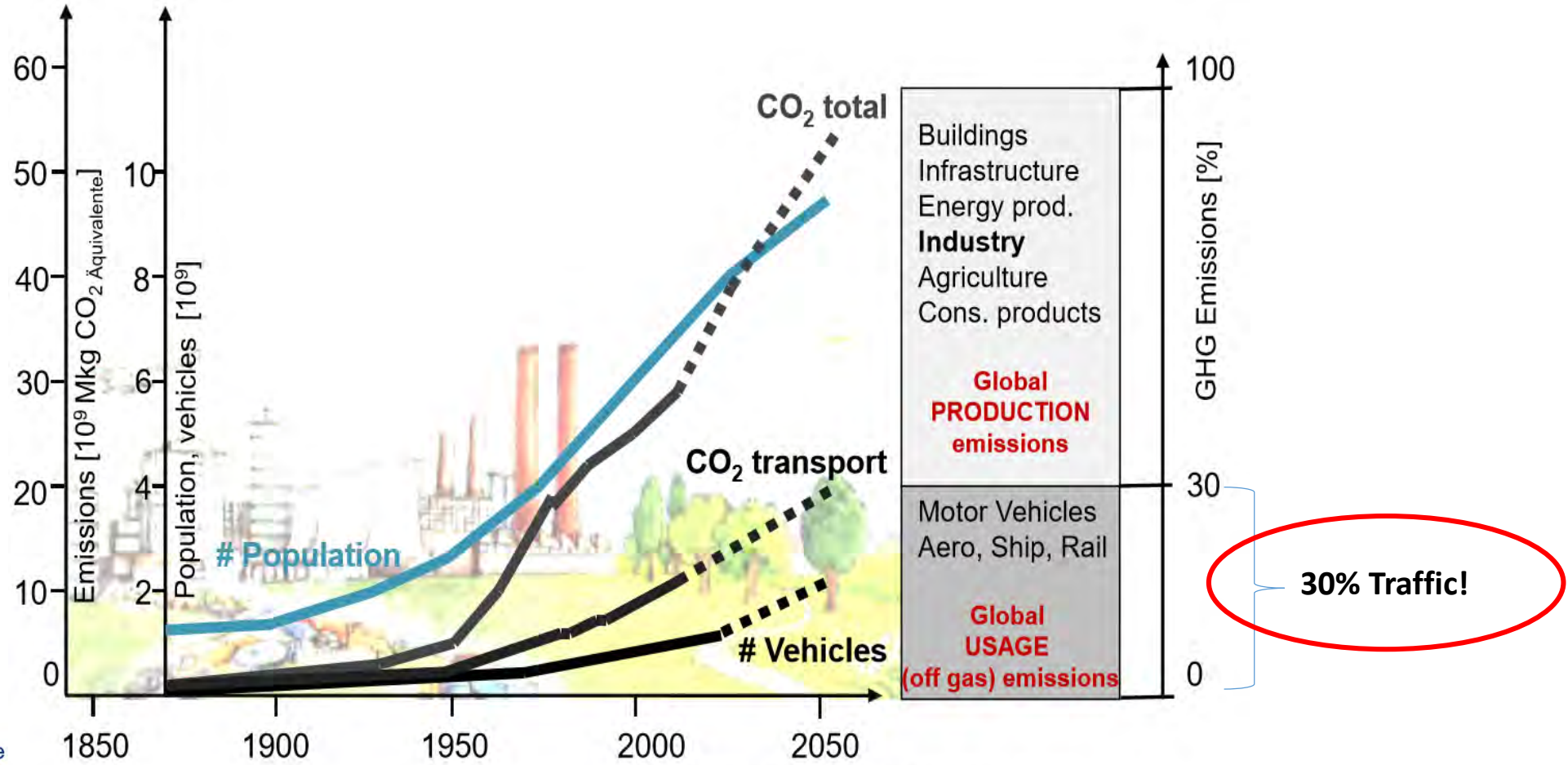

Forecast: World energy demand in regions increases

World primary energy demand by region in the New Policies Scenario

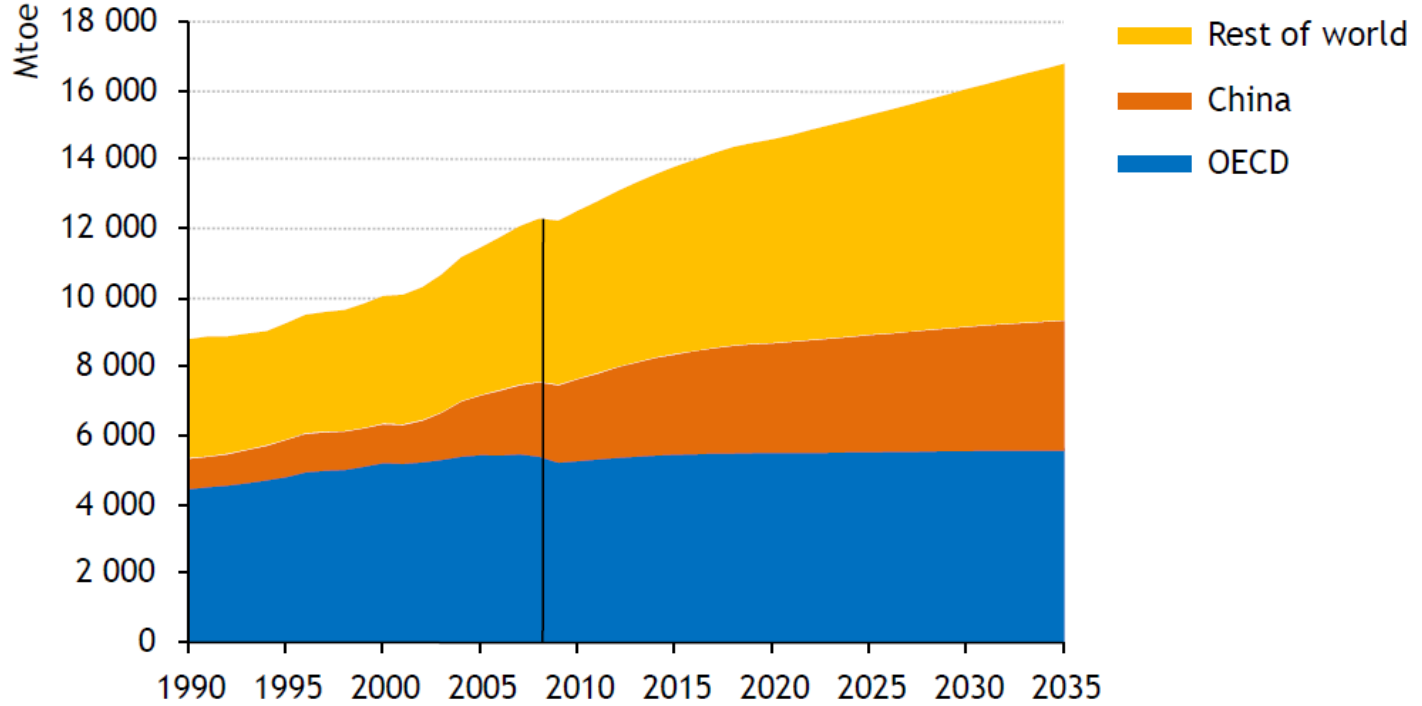

Global energy use grows by 36%, with non-OECD countries – led by China, where demand surges by 75% – accounting for almost all of the increase

Source: F. Birol, IEA

Fuels for engines

Trends – crude oil cannot be forever

- Overall intrinsic finite and instable nature of fossil fuel supply
- Crude oil reserves a **”moving target”**: no certainty on its end of usage and production
- “Peak oil” production soon achieved?
- According to experts, **no real shortage** of fossil fuels or hydrocarbons in sight for the next few decades
- Production will get more expensive > price-problem
- **Conclusion: anyway, the fossil age will be short!**

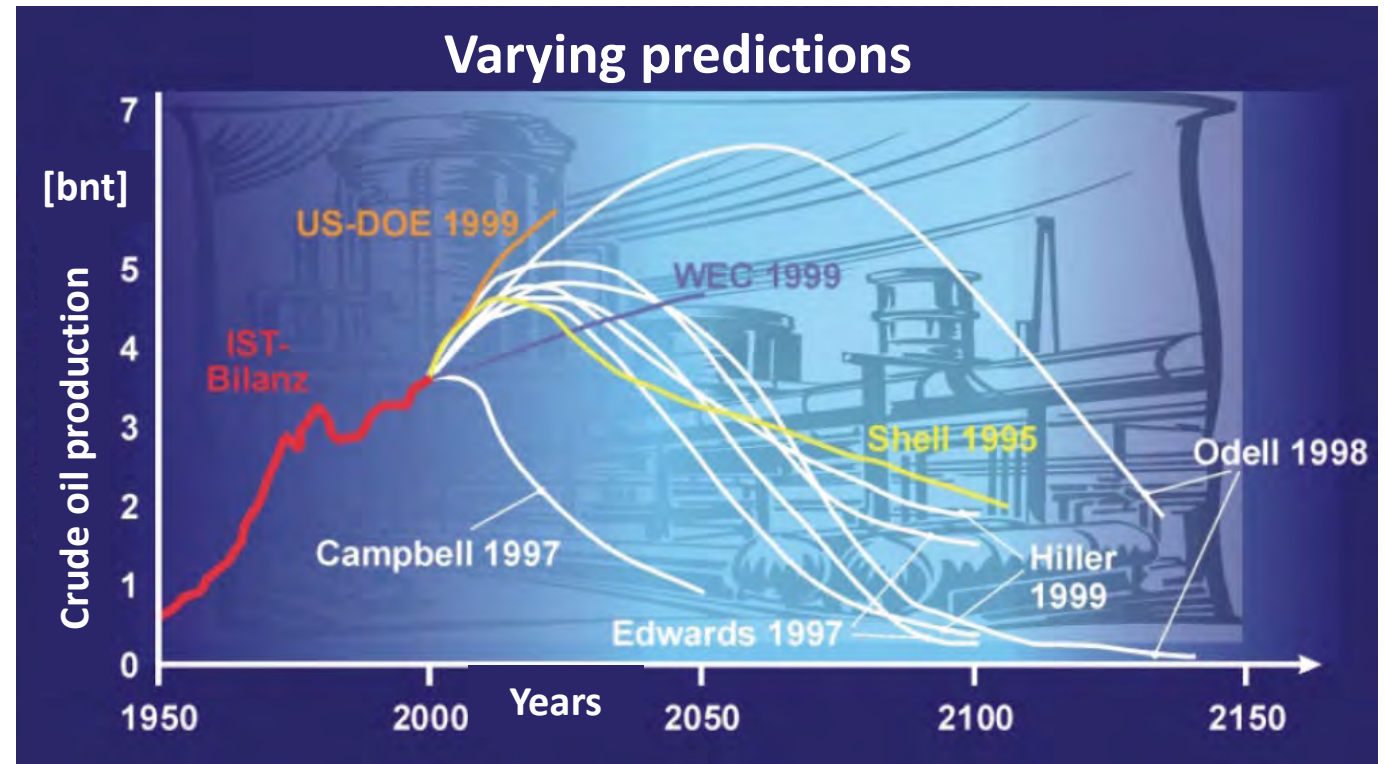

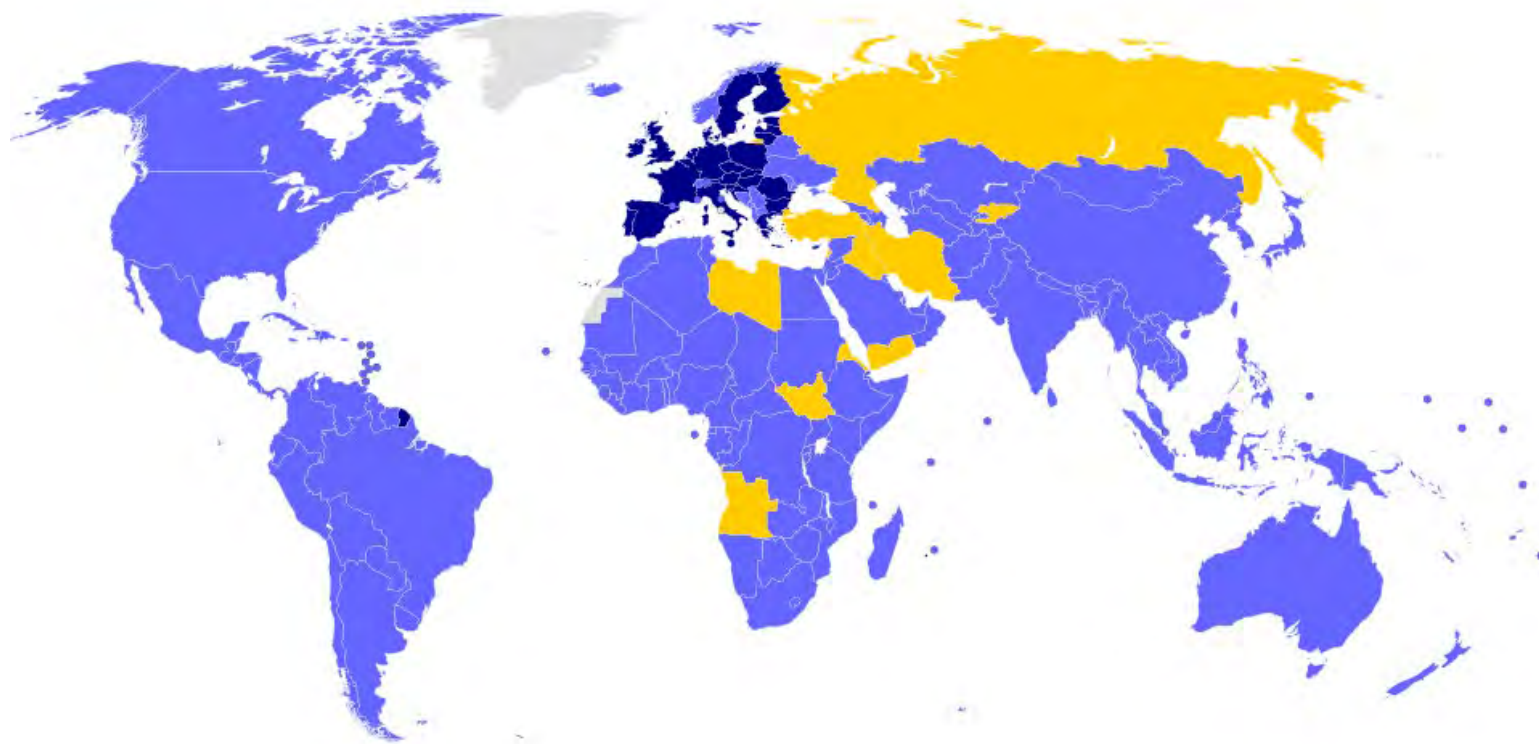

Actions: CO₂ Target and Paris Treaty - to reduce Global Warming



- Keep CO₂ emissions so low that the global warming stays well below **2 deg.C**
- EU-goal at least -80% to -95% reduction of CO₂ until 2050

Paris Treaty:

- States signed and ratified 
- States signed but not ratified 
- States of EU signed & ratified 



Co-funded by the
Erasmus+ Programme
of the European Union

FOR EDUCATIONAL PURPOSE ONLY

Source:[CC BY-SA 4.0](https://creativecommons.org/licenses/by-sa/4.0/)

File:ParisAgreement.svg

Erstellt: 22. April 2016

https://de.wikipedia.org/wiki/%C3%9Cbereinkommen_von_Paris

Action: worldwide Legislation to reduce CO₂ from cars

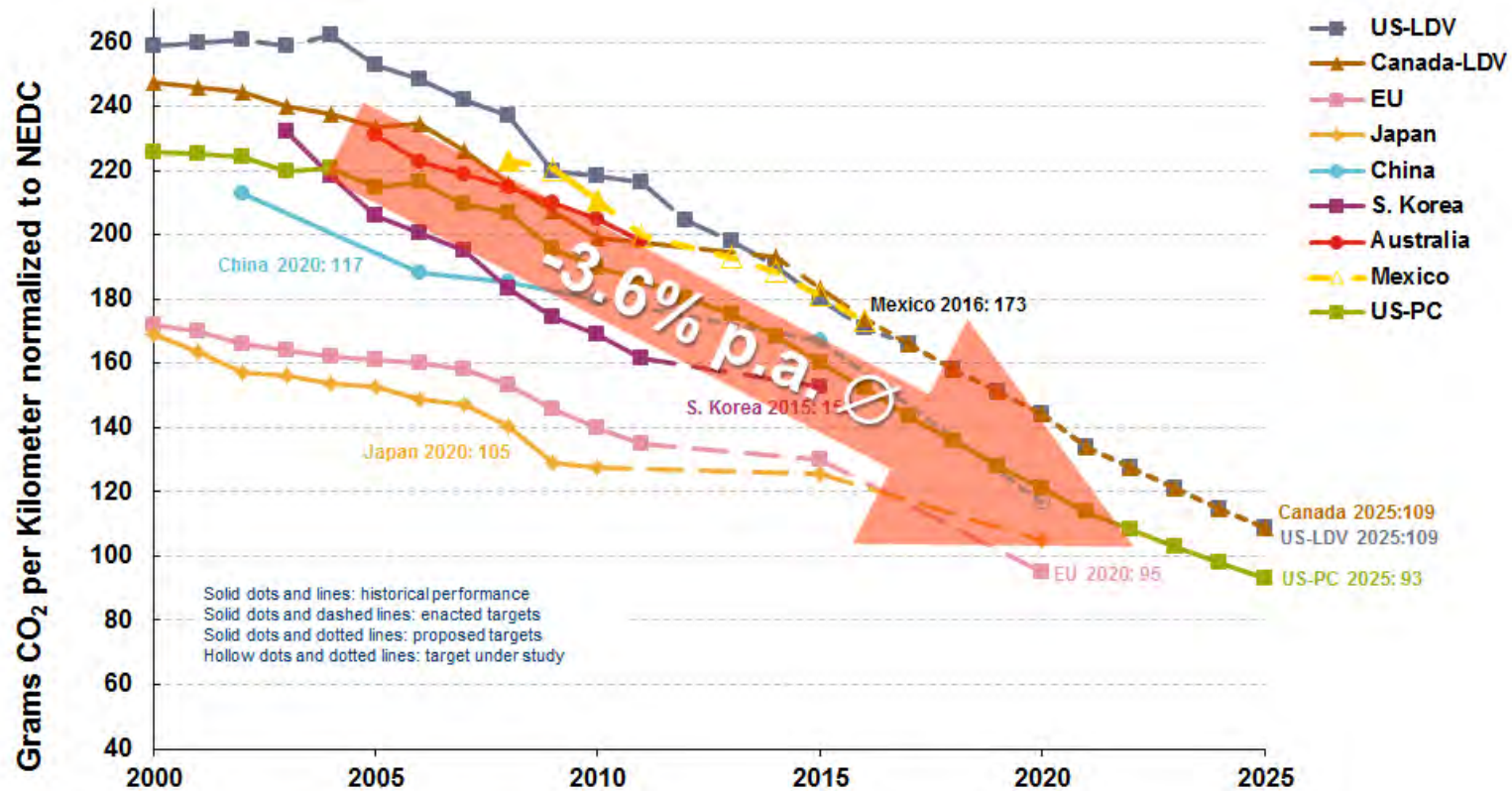

- Worldwide Agreement to reduce CO₂ emissions from cars
- Gradient of reduction required ~ 4% per year
- 2030 approx. 60 gCO₂/km need to be reached
- Cannot be achieved by “conventional” measures and by further development of existing technology

Required Action: Change to renewable Energy and alternative Fuels



Fossil Fuels

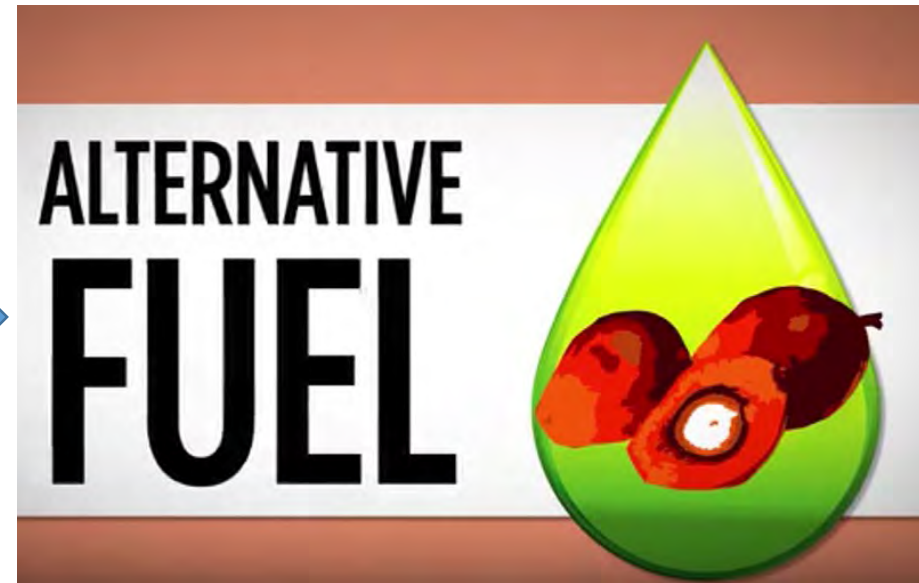

Alternative Hydrocarbon Fuels, when high energy density is inevitable (high power over long duration):

- Long Haule Trucks
- Big ships
- Aeroplanes

Required Action: Change to renewable Energy and alternative Fuels



Fossil Fuels

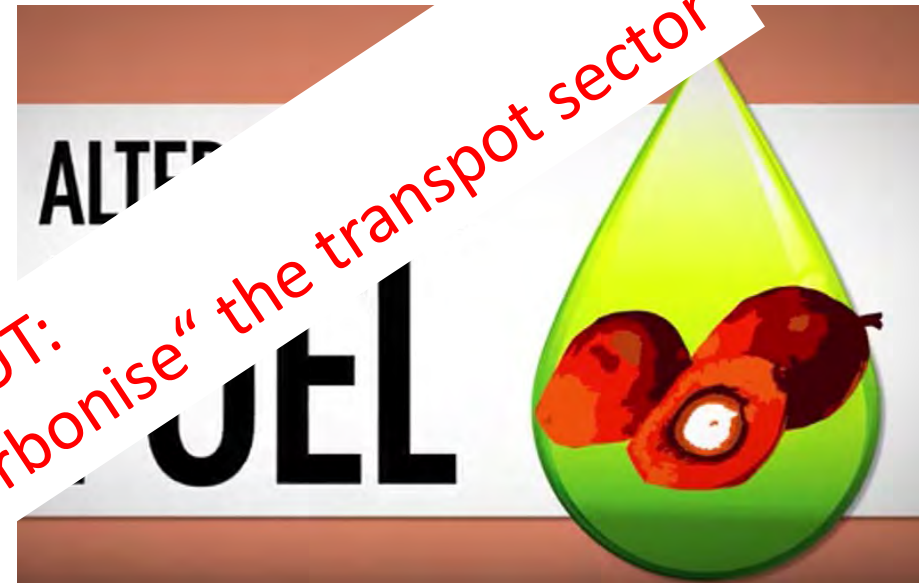

Alternative Hydrocarbon Fuels, when high energy density is inevitable (high power over long duration):

- Long Haule Trucks
- Big ships
- Aeroplanes

BUT: Politicians want to "decarbonise" the transport sector

Fuels for ic - engines – Future fuel trends

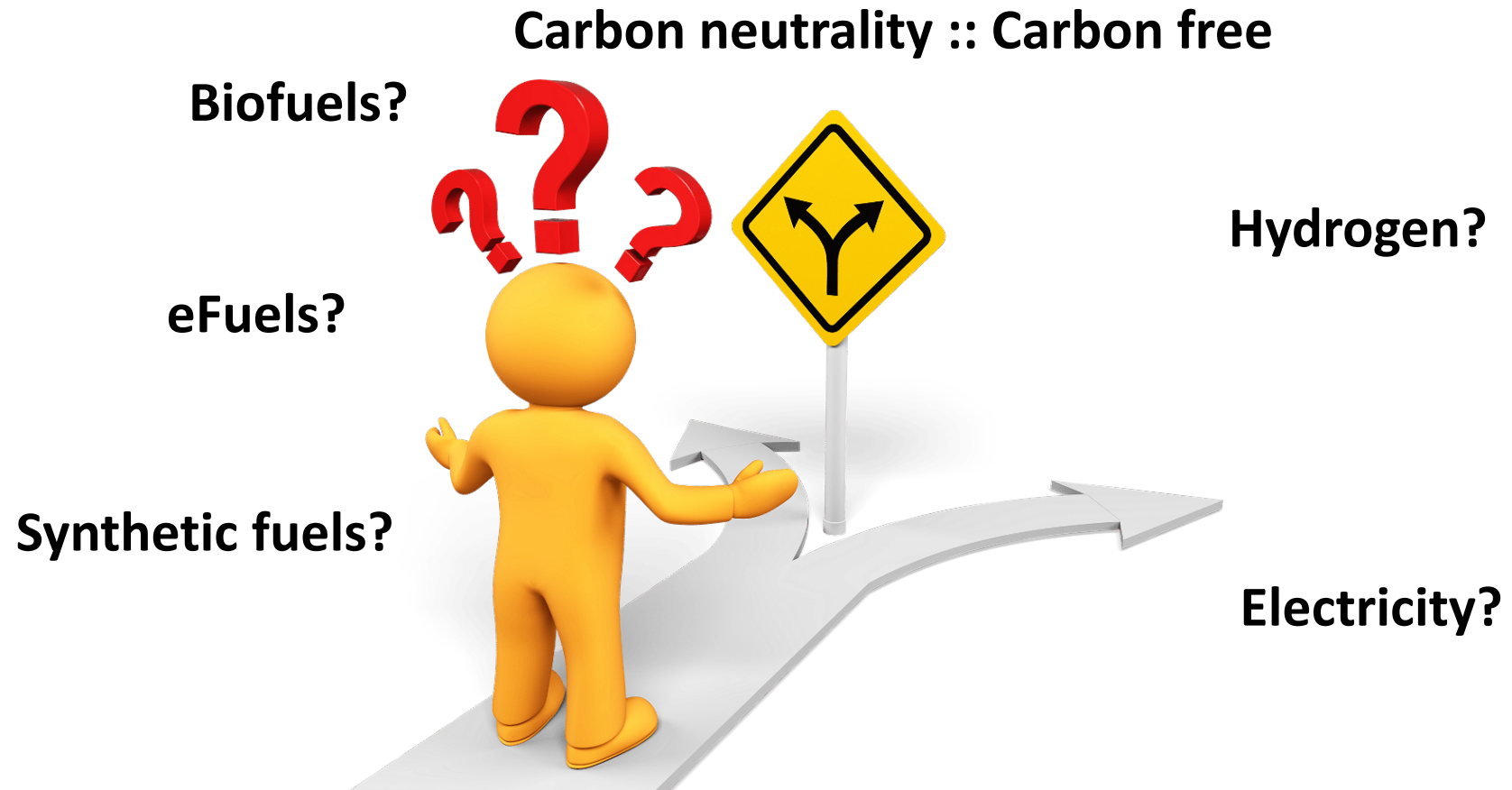

Co-funded by the
Erasmus+ Programme
of the European Union

Source:
- <http://revell-accounting.com/>

Proposal from ERTRAC

European Road Transport Research Advisory Council

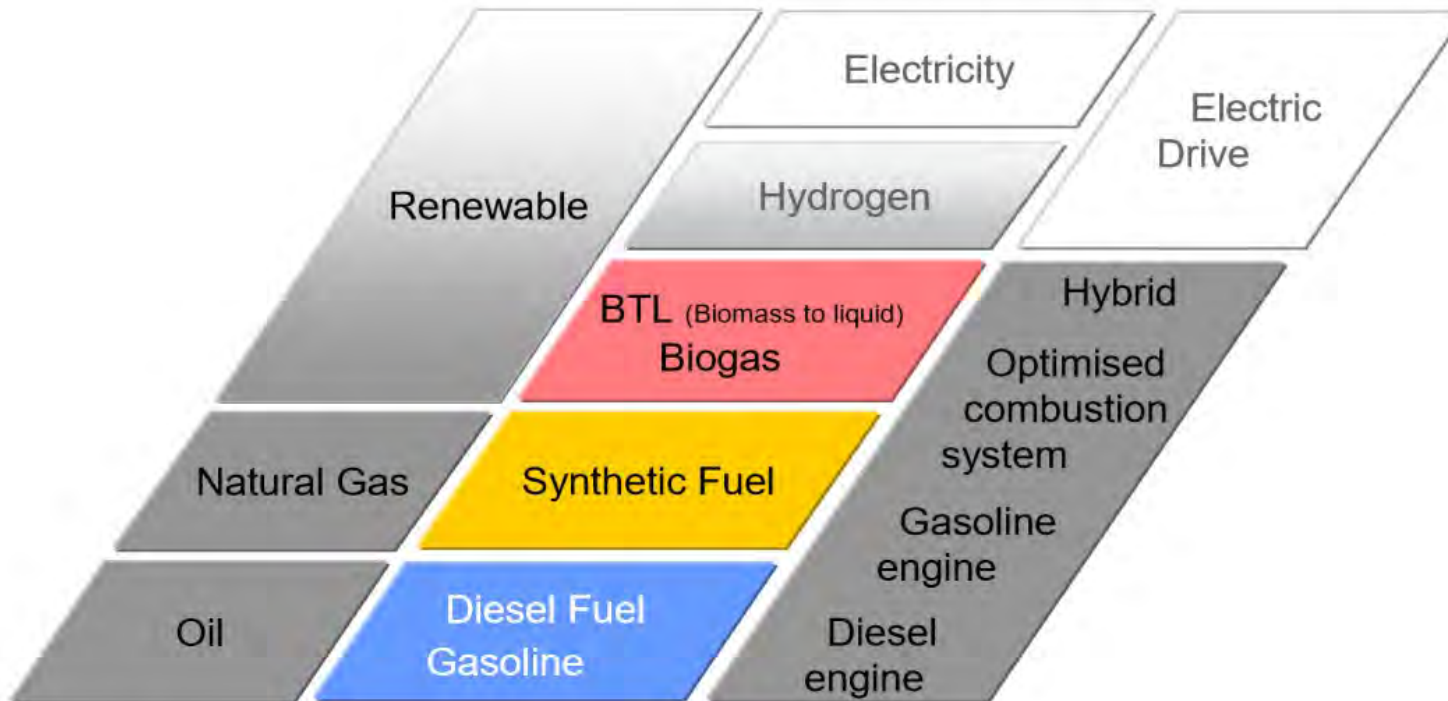

- Fuel options for the future
- Will all of them be used??

Fuel and vehicle propulsion strategy (Source: ERTRAC)



Co-funded by the
Erasmus+ Programme
of the European Union

Fuel Options for ic-engines – Future fuel trends



Worldwide rising prices and environmental concerns **increase political pressure against coal, nuclear fuels and crude oil** in particular. Over the next few decades all experts agree on their gradual substitution in favor of:

- **Bio fuels:** carbon neutrality by a circular CO₂ process
- **Synthetic fuels:** higher purity, if obtained from renewable sources -- > carbon neutrality
- **Pure electricity** from renewable sources & **eFuels** (PtG (Power to Gas))
- **Hydrogen:** produced via hydrolysis from renewable energy sources

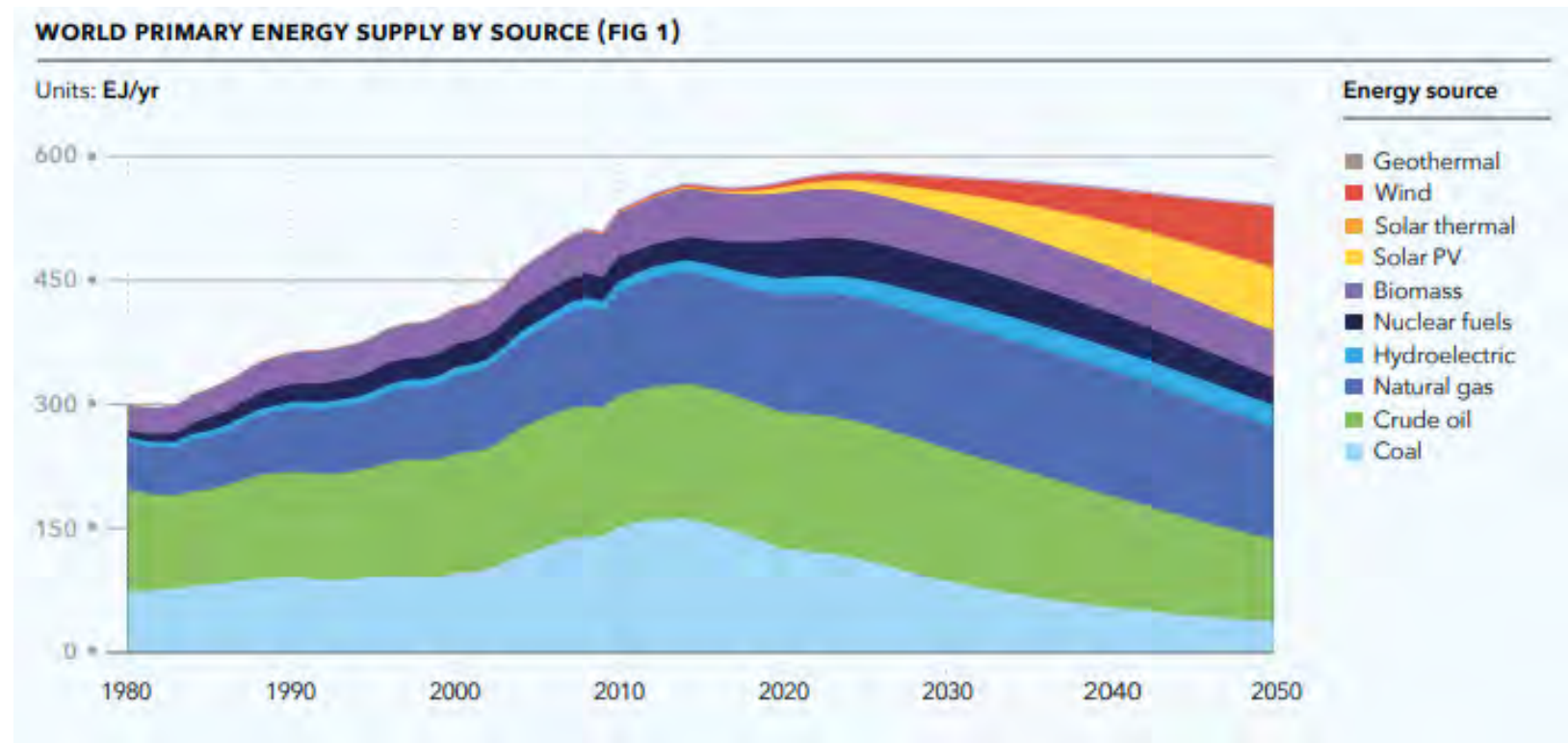

Which Fuel Path will make the race ?

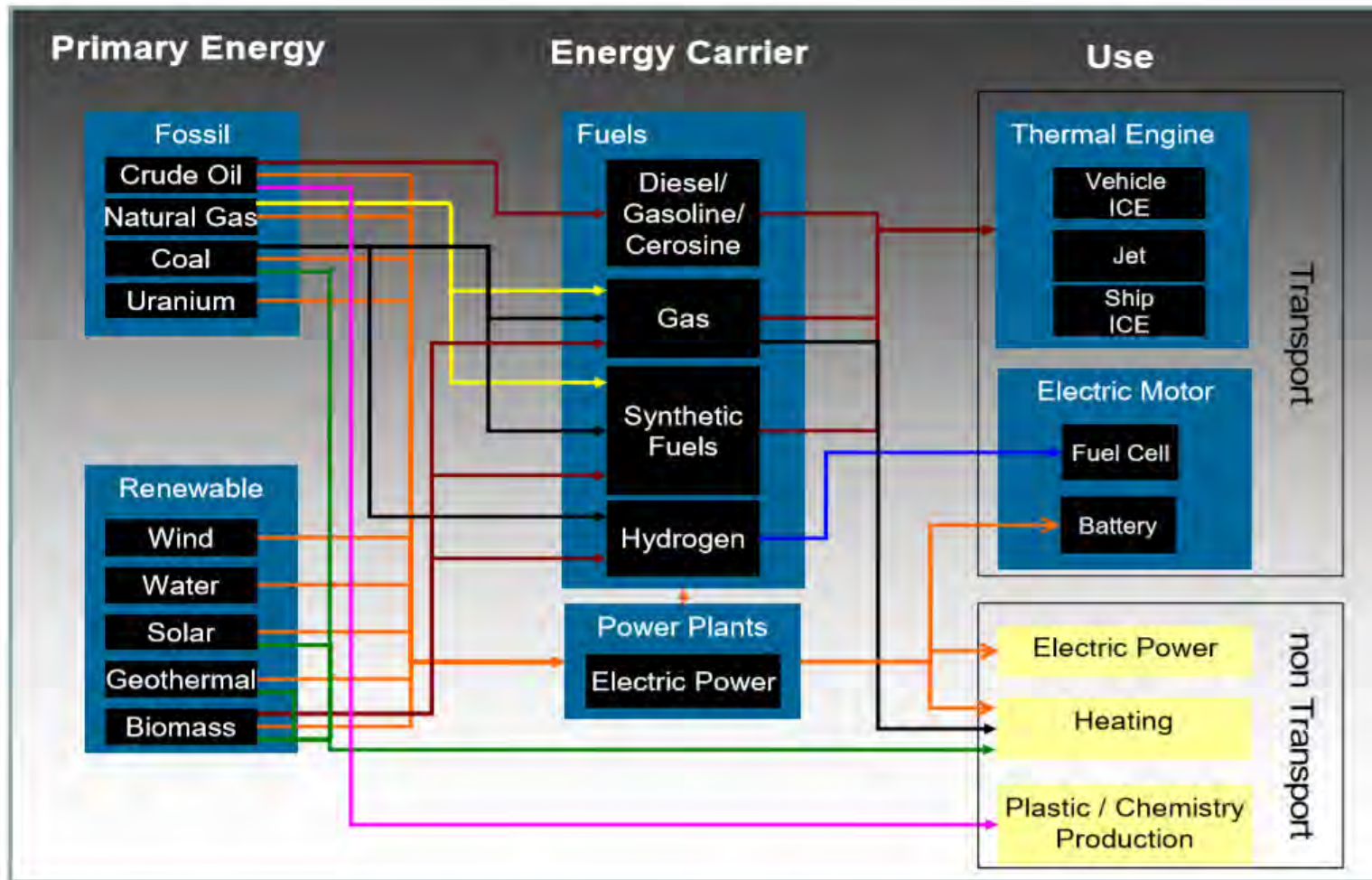

Energy pathways in transport and other sectors (Source: ERTRAC)

Future Transport Fuels
Report of European Expert Group
on future Transport Fuels, January 2011

Everybody asks for renewable energy ??



Land requirement necessary to drive a vehicle over 12.000 km per year

5000 m² for Bio-diesel plus ICE

1000 m² for H₂ out of Biomass + fuel cell

500 m² for hydrogen produced by electricity from wind power

65m² for Photovoltaic plus fuel cell

20m² for Photovoltaic + battery electric powertrain



Quelle: ZSW 2010



Co-funded by the
Erasmus+ Programme
of the European Union

FOF

Source: https://www.dlr.de/tt/Portaldata/41/Resources/dokumente/ec/Friedrich_Electromobilitaet.pdf

Different sectors will require different solutions



The different Transport modes require different options of alternative fuels:

- **Road transport** could be powered by electricity for short distances, hydrogen and methane up to medium distance and biofuels/synthetic fuels, LNG, LPG up to long distances.
- **Railways** should be electrified wherever feasible, otherwise use biofuels or hydrogen.
- **Aviation** should be supplied from biomass derived kerosene.
- **Waterborne transport** could be supplied by biofuels (all vessels), hydrogen (inland waterways and small boats), LPG (short sea shipping), LNG and nuclear.



Propulsion 2050 – most likely Scenario



CONSEQUENCES FOR ROAD VEHICLE PROPULSION



Commercial Vehicles:

- Off-road propulsion with regenerative fuels
- Plug-in hybrid propulsion for N1 and N2 trucks
- Pure electric buses (battery and/or fuel cell)

Passenger Vehicles:

- Fully electric propulsion (inner city)
- Fuel cell electric or hybrid propulsion
- 100% regenerative fuels (H2 from regenerative sources, bio-waste-based fuels)



Co-funded by the
Erasmus+ Programme
of the European Union

FOR EDUCATIONAL PURPOSE ONLY

Source: P.Prenninger, AVL
10. A3PS Conf. Nov. 2016

Fuel Options for ic-engines

Content :

- Basics & Overview
- Bio-fuels
- Synthetic Fuels and E-Fuels
- Hydrogen

- Discussion



Fuel Options for ic-Engines - Basics

The fuel used defines the **engine types** and thus **his output** (power, NVH, emissions)!

Learning targets:

- Understanding of the ignition process resulting in engine types
- Which fuels exist
- Define the most important characteristics
- Learn the general and specific properties related to engines
- Understand trend/ Outlook to future fuels



Fuel Options for different ic-Engines

- **Spark Ignited (SI)** engines can use:

- Gasoline
- Alcohols: (bio-) ethanol
- Gaseous Fuels: Compressed Natural Gas (CNG); Liquified Petroleum Gas (LPG); biogases (Methane); Hydrogen
- Ignition needs to be **supported by a spark plug**

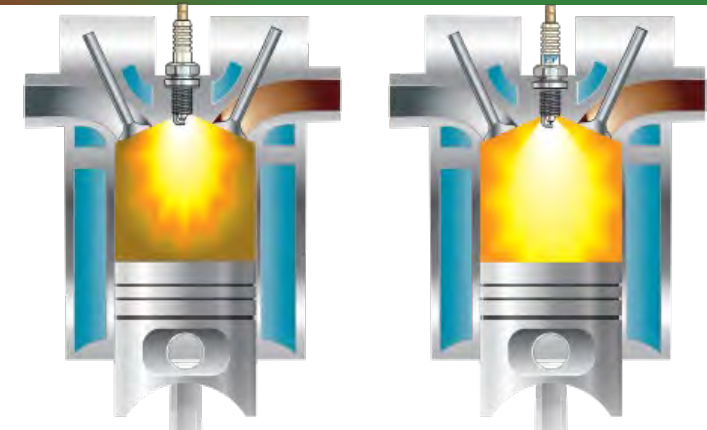

- **Compression ignited (CI)** engines can use:

- Diesel, Biodiesel, Rapeseed Methyl Ester (RME); DME
- Regarding CI engines, very small or none engine tuning is required when switching
- **Self-ignition** when temperature and pressure is high enough

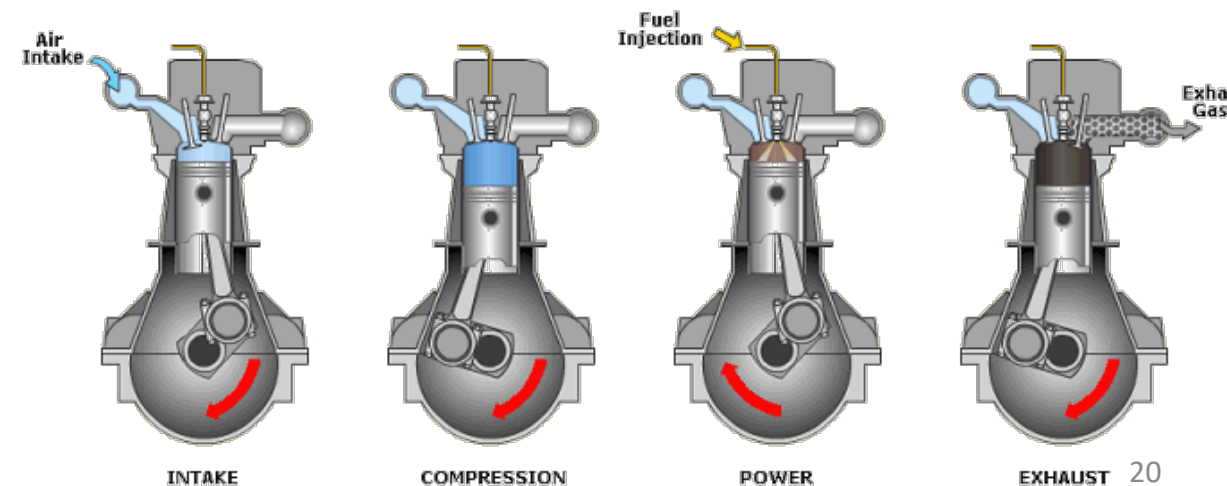

Fuel Options for ic-Engines

- Production from Crude Oil

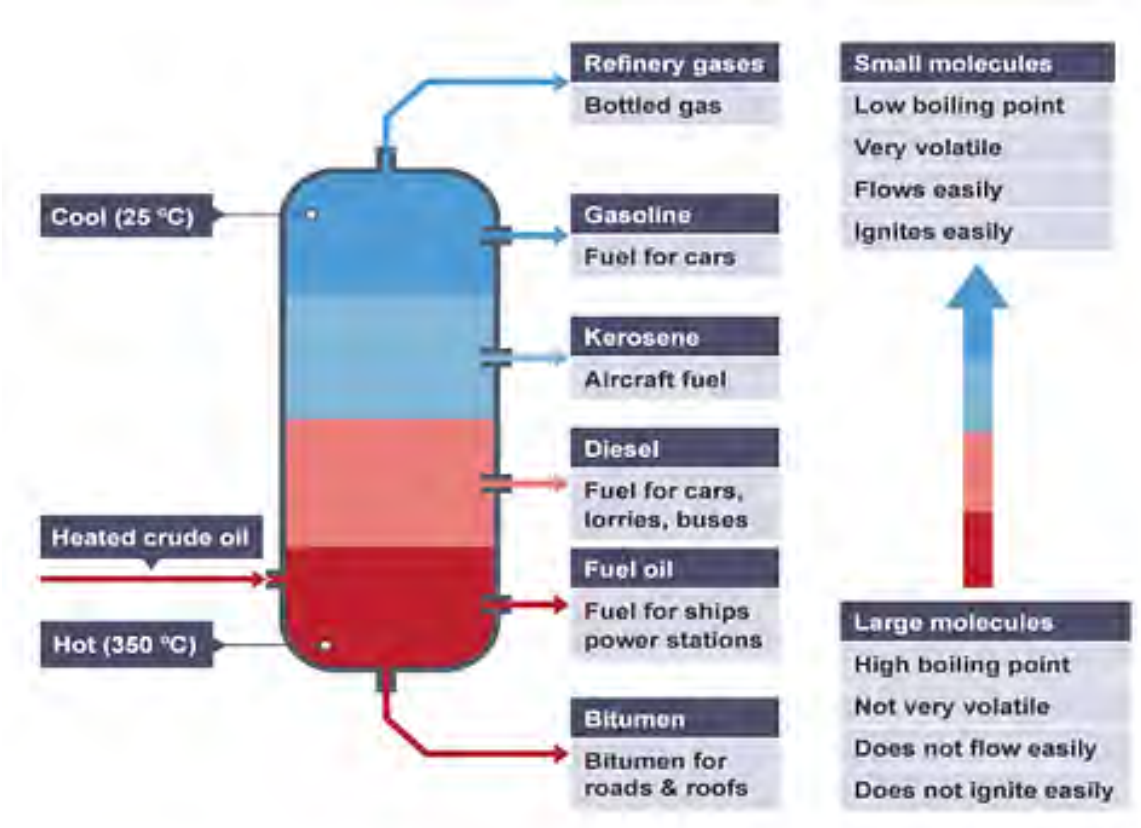

Refinery products

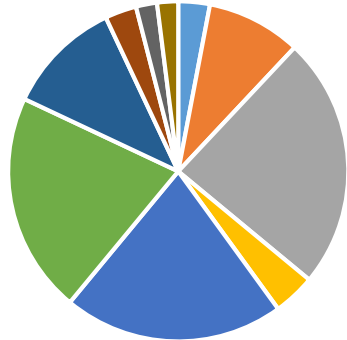

- 3% Liquefied propane butane
- 9% Raw petroleum, naphta
- 24% Petrol/gasoline
- 4% Jet fuel, kerosene
- 21% Diesel fuel
- 21% Light heating oil
- 11% Heavy heating oil
- 3% Bitumen
- 2% Lubricants
- 2% Others

Standard Fuels for engines

Chemical Nature



- All fossil fuels from crude oil are **mixtures of hydrocarbons**. The fuel properties are defined by the following parameters:
 - Chemical weight/volume analysis
 - Relation between the C-atoms and H-atoms numbers
 - Structure (i.e. chains or rings)

It is important to point out that **no fixed composition** exists: many variances of the same fuel are produced, depending on the field of utilization. So it is better to offer average values.

Gasoline average properties:

- 87 % C and 13% H
- $C_{7.2}H_{12.6}$
- 4-8% alkanes; 2-5%
- Mostly **saturated hydrocarbons** (4-8% alkenes; 25-40% isoalkanes; 3-7% cycloalkanes; 1-4% cycloalkenes); and 20-50% **aromatics** (0.5-2.5% benzene)

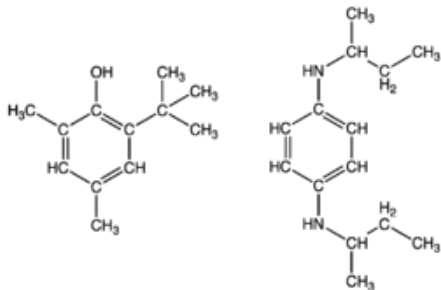

Diesel average properties:

- 85 % C ,14% H and 1% impurities and additives
- $C_{12}H_{24}$ (from $C_{10}H_{20}$ to $C_{15}H_{28}$)
- 75% **saturated hydrocarbons** (primarily alkanes including n, iso, and cycloalkanes); 25% **aromatics** (including naphthalenes and alkylbenzenes)

CNG average properties:

- 75 % C, 25% H
- CH_4
- Between 85 and 99% **methane**; ethane, propane, butane and pentane in **small and variable quantities**.

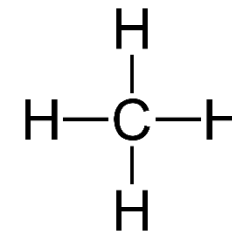

Sources and further reading:

- <http://webserver.dmt.upm.es/~isidoro/bk3/c15/Fuel%20properties.pdf>
- <https://en.wikipedia.org/wiki/Gasoline>
- <https://www.atsdr.cdc.gov/toxprofiles/tp72-c3.pdf>
- <http://www.newworldencyclopedia.org/entry/Diesel>
- <http://www.dynamicscience.com.au/tester/solutions1/chemistry/organic/diesels.html>
- <https://www.uniongas.com/about-us/about-natural-gas/chemical-composition-of-natural-gas>



Co-funded by the
Erasmus+ Programme
of the European Union

LNG (Liquified Natural Gas)

- Liquefied natural gas is produced by cooling natural gas to approx. $-161^{\circ} \sim -164^{\circ} \text{C}$ (112 to 109 K) ;
- LNG has only 1/600 of the volume of gaseous methane.
- Natural gas is usually transported via pipe lines to a LNG Terminal where it is cooled and purified. Normally natural gas contains also „heavier“ hydrocarbons, nitrogen, CO_2 , sulfur and water. After purification it is distributed by big tanker ships to their destination.
- Especially for transport and storage LNG has big advantages and can be distributed in special tanks.
- In Europe big efforts are being made to introduce LNG in the inland navigation on the big rivers like Rhein or Danube. Harbor for the distribution is Rotterdam.
- In this course truck application is coming up.



LPG (Liquified Petroleum Gas, Auto Gas)

Condition	gaseous under normal condition, liquid when pressurized
Density	0,54–0,60 kg/L (under pressure)
Calorific. Value Hu	46 MJ/kg, 12,8 kWh/kg; 24,8 MJ/L, 6,9 kWh/L
Octane No.	105-115 ROZ (depending on mixture)
Boiling Range	Propan: -42 °C, Butan: -0,5 °C
CO ₂ emission when burned	0,236 kg (CO ₂) /kWh = 1,64 kg (CO ₂) /L = 3,04 kg (CO ₂) /kg

- LPG (Liquefied Petroleum Gas) is a by-product of the hydrocarbon fuel chain, currently resulting from oil and natural gas, in future possibly also from biomass.
- It is mixture of Propane and Butane
- LPG is currently the most widely used alternative fuel in Europe, accounting for 3% of the fuel for cars and powering 5 million cars.
- The core infrastructure is established, with over 27,000 public filling stations. Single-fuel solutions covering all transport modes would be technically possible with liquid biofuels and synthetic fuels.
- But (fossil) feedstock availability and sustainability considerations constrain their supply potential.



#47231903



Methane CH₄ from Bio-mass



- Among all biofuels, biogas/biomethane offers the best results in terms of energy production potential and land efficiency, and it is also the only one able to be efficiently produced from several different sources.
- Bio-methane is usually not pure and comes along with high content of CO₂, nitrogen, sulfur compounds and other components. To purify the bio-methane causes high efforts and additional energy is necessary.
- Plants need to have a certain magnitude to guaranty a constant quality. This mix of gases might be ignored for heating purposes, but efficiency of ICEs depends on a constant fuel quality and practically engine parameters cannot be adjusted “online” all the time, if the fuel quality changes.
- Bio-methane can be mixed with natural gas at any percentage and without any problem for the vehicle engines.
- Methane in general allows higher compression ratio, is less knocking sensitive and thus leading to higher thermal efficiency of the ice engine.



Typical gas composition of gaseous fuels for large engines



Gas type	CH ₄	C ₂ H ₄	C ₂ H ₆	C ₃ H ₈	C ₄ H ₁₀	H ₂	CO	CO ₂	N ₂	Others
Natural Gas	75-98	-	0,6-7,2	0,2-1,3	0,1-0,6	-	-	0,1-1,6	0,8-9,8	1-11
Oil accomp.Gas	60-90	-	2-20	3-15	2-10	-	-	-	-	-
Sewer Gas	60-66	-	-	-	-	0-3	-	32-33	1-5	-
Bio Gas	45-70	-	-	-	-	0-1	-	25-55	0,01-5	0-10
Landfill Gas	45-50	-	-	-	-	-	-	35-40	9-15	0-1
Wood Gas	3-7	0-2	-	-	-	6-19	9-21	11-19	42-60	-
Coke Gas	25-31	-	0-1,6	-	-	54-57	5,5-8	1,2-2,3	3,8-9,7	0-1
Furnance Gas	-	-	-	-	-	2-4	20-30	20-25	45-60	-
Mine Gas (CSM)	25-60	-	-	-	-	-	0,1-0,4	1-6	4-40	7-17

Ethanol (E5, E10 blends)



Production process

EtOH is a naturally widespread chemical, produced by ripe fruits and by wild yeasts or bacteria through fermentation. Ethanol from biomass can be produced from any feedstock containing appreciable amounts of sugar or materials that can be converted into sugar. Fermentation (biotechnology) is the predominate pathway for EtOH production. Biomass can also be converted to EtOH via biotechnological and thermochemical pathways.

Biochemical pathways

The most common raw materials are sugar cane and corn, and in temperate climates also sugar beet, wheat or potatoes. The overall fermentation process starting from glucose is:

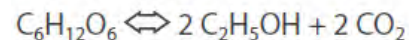

Naturally, the underlying biochemical processes are much more complicated. Adapted yeasts, for example *Saccharomyces cerevisiae* are used and fermentation can be carried out with or without the presence of oxygen. With oxygen some yeasts are prone to respiration, the conversion of sugars to carbon dioxide and water. As EtOH is a toxin, there is a limit to the maximum concentration in the brew produced by the yeasts. This results in a high energy demand for EtOH purification by distillation.

State of the Art

Global bioethanol production in 2011 has been estimated at 84.6 BI. The United States is the leading producer with 52.6 BI (62%), while Brazil produced 21.1 BI (25%). The EU-27, with a production of 5467 MI (4.6%), ranks third behind these two majors producers.

As an alternative to using sugar- and/or starch-based biomass, R&D is focused on advanced processes that use lignocellulosic materials as feedstocks. These processes have the potential to increase the variety and quantity of suitable feedstocks, including cellulosic and food-processing wastes, corn stovers and cereal straws, as well as dedicated fast-growing plants such as poplar trees and switch-grasses. Advanced processes include biomass pre-treatment to release cellulose and hemicellulose, hydrolysis to fermentable 5- and 6-carbon sugars, sugar fermentation, thermal conversion of solid residues and non-hydrolysed cellulose, and distillation of ethanol to fuel grade. In order to provide better conversions, new pretreatment schemes and innovative enzymatic processes have been investigated.

Applications

Low-percentage ethanol-gasoline blends (E5, E10) can be effectively used in most conventional spark-ignition engines with no technical changes, while modern flexi-fuel vehicles (FFV), which can run on any gasoline-EtOH mixture up to 85% EtOH (E85), are made with just a few modifications during production. The use of alcohol fuels, such as ED95, in heavy duty applications is also implemented on a limited scale.

EtOH has a series of technical advantages as a fuel for spark-ignition engines. First, EtOH has a very high octane number. This gives the fuel a strong resistance to knock which translates into the possibility of optimizing the engine by increasing compression ratio and advancing spark. Second, EtOH has a high heat of vaporization, enabling an air-cooling effect. This enhances the filling efficiency, partly offsetting its lower energy content per litre. Finally, the presence of oxygen in the ethanol molecule provides a more homogeneous fuel-air mix formation and permits low-temperature combustions with a consequent decrease in unburned or partially burned molecule emissions (HC, CO, and NOx).

Source:

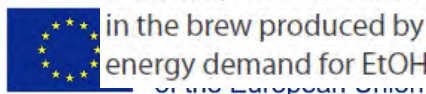
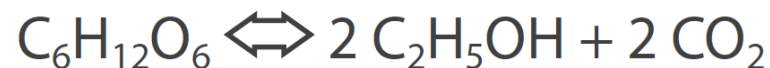

Methanol (from Biomass)

Introduction

Methanol, also known as methyl alcohol, wood alcohol, or wood spirits, is often abbreviated as MeOH. It is the simplest alcohol, and is a light, volatile, colourless, flammable liquid with a distinctive odour. At room temperature it is a polar liquid. MeOH is miscible with water, petrol and many organic compounds. MeOH burns with an almost invisible flame and is biodegradable. Without proper conditions, methanol attracts water while stored. Methanol is a safe fuel. The toxicity (mortality) is comparable to or better than gasoline. It also biodegrades quickly (compared to petroleum fuels) if spilled.

State of the Art

MeOH has grown into one of the largest chemical synthesis feedstocks. Key uses include production of formaldehyde, MTBE/TAME (petrol additives), acetic acid, DME and olefins and direct use as a petrol blend component.

In 2007 the world production of MeOH amounted to 40 million tonnes with a forecast compound annual growth rate of 4.2 % for the period 2008-2013 excluding captive production for the methanol-to-olefins (MTO) route. Today, methanol from biomass is produced through gasification of glycerine, a by-product of biodiesel production, by BioMCN in the Netherlands. The thermochemical conversion of syngas to methanol is well known from fossil feedstocks and the basic steps are not different for biomass. The main issue faced is the economic feasibility of gasification of biomass at elevated pressures and conditioning of the raw synthesis gas.

Molecular Formula

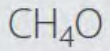

Comparison of Fuel Properties

Property	Methanol	Petrol
Density at 20 °C [kg/l]*	0.79	0.74
Lower heating value [MJ/kg]*	19.7	43.9
Octane number	>110	92
Fuel equivalence	0.48	1
GHG [gCO ₂ eq/MJ]**	Waste wood methanol: 5 Farmed wood methanol: 7	

Source: *FNR 2012. Median values are used for simplification. Please refer to standards for ranges. ** Directive 2009/28/EC, total for cultivation, processing, transport and distribution

Source:



Blends up to 3 % as per current EU standard EN228

Production process

In nature MeOH is produced via anaerobic metabolism by many bacteria. It is also formed as a by-product during the ethanol fermentation process. MeOH also occurs naturally in many plants, especially in fruits. MeOH is mainly synthesized from natural gas, but also from coal, mainly in China and South Africa. Biomass can be converted to MeOH via thermochemical and biotechnological pathways as shown in the following diagram.

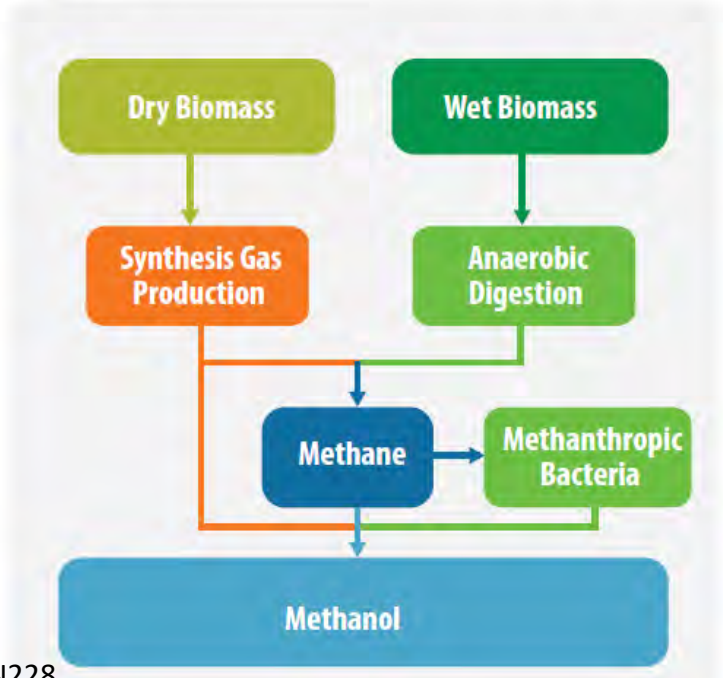

Overview Production of Renewable Bio - Fuels

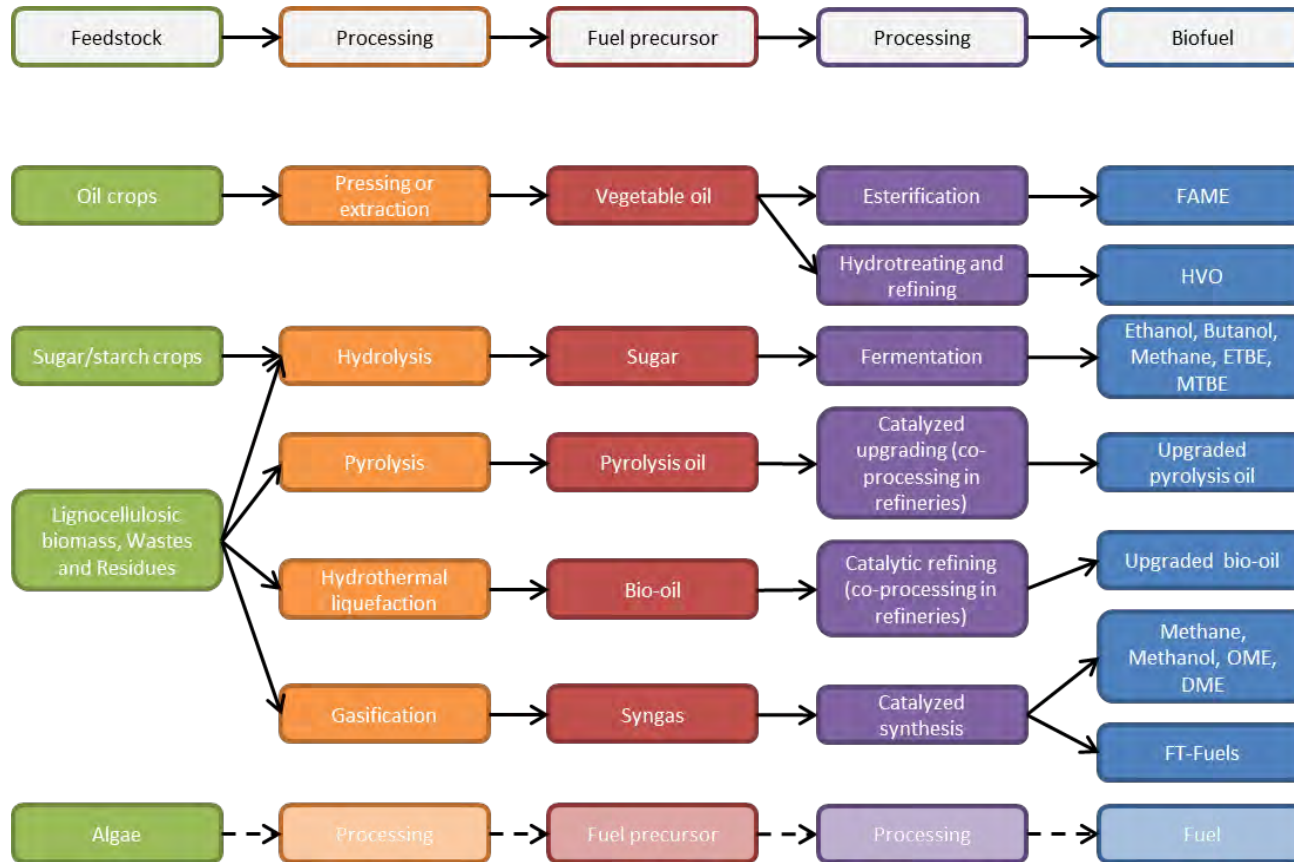

Legend

- FAME Fatty Acid Methyl Esters
- HVO Hydro-treated Vegetable Oil
- ETBE Ethyl-tert-butylether
- MTBE Methyl-tert-butylether
- OME Polyoxymethylenedimethylether
- DME Dimethylether
- FT-Fuel Fischer-Tropsch Process

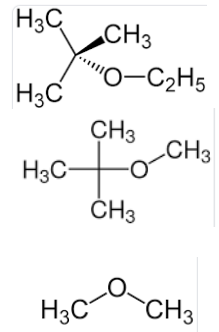

Source: A3PS Roadmap 2018

FAME – Fatty Acid Methyl Esters

Production process

FAME is produced from vegetable oils, animal fats or waste cooking oils by transesterification. In the transesterification process a glyceride reacts with an alcohol in the presence of a catalyst, forming a mixture of fatty acids esters and an alcohol. Using triglycerides results in the production of glycerol.

Transesterification is a reversible reaction and is carried out by mixing the reactants. A strong base or a strong acid can be used as a catalyst. At the industrial scale, sodium or potassium methanolate is mostly used. The following reaction occurs:

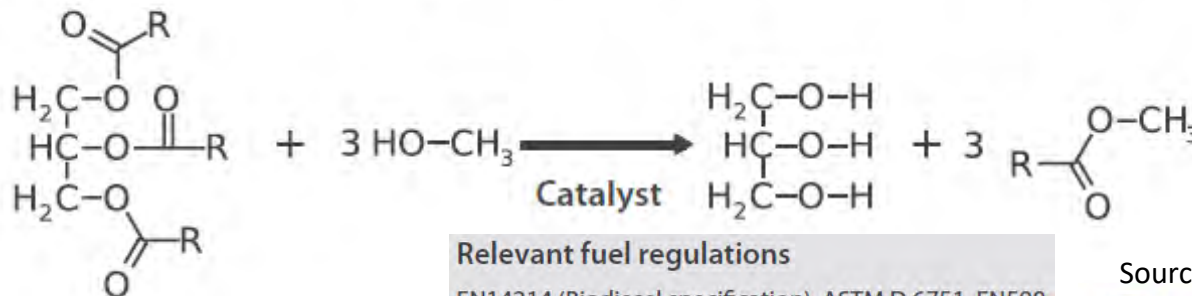

Relevant fuel regulations
EN14214 (Biodiesel specification), ASTM D 6751, EN590

Source:



Molecular Formula

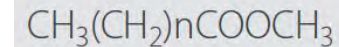

Comparison of Fuel Properties

	FAME	Diesel
Density at 20 °C [kg/l]*	0.88	0.83
Lower heating value [MJ/kg]*	37.1	43.1
Viscosity at 20 °C [mm ² / s]*	7.5	5.0
Cetane number*	56	50
Fuel equivalence*	0.91	1
GHG [gCO ₂ eq/MJ]**	Rape seed biodiesel: 46 Waste vegetable or animal oil biodiesel: 10 Palm oil biodiesel (process not specified): 54	

Source: FNR 2012. * Median values are used for simplification. Please refer to the standards for ranges. ** Directive 2009/28/EC, total for cultivation, processing, transport and distribution



Co-funded by the
Erasmus+ Programme
of the European Union

Who uses Palm Oil in Europe?

Palm oil use in Europe's cars: comparisons

EU CARS USE:

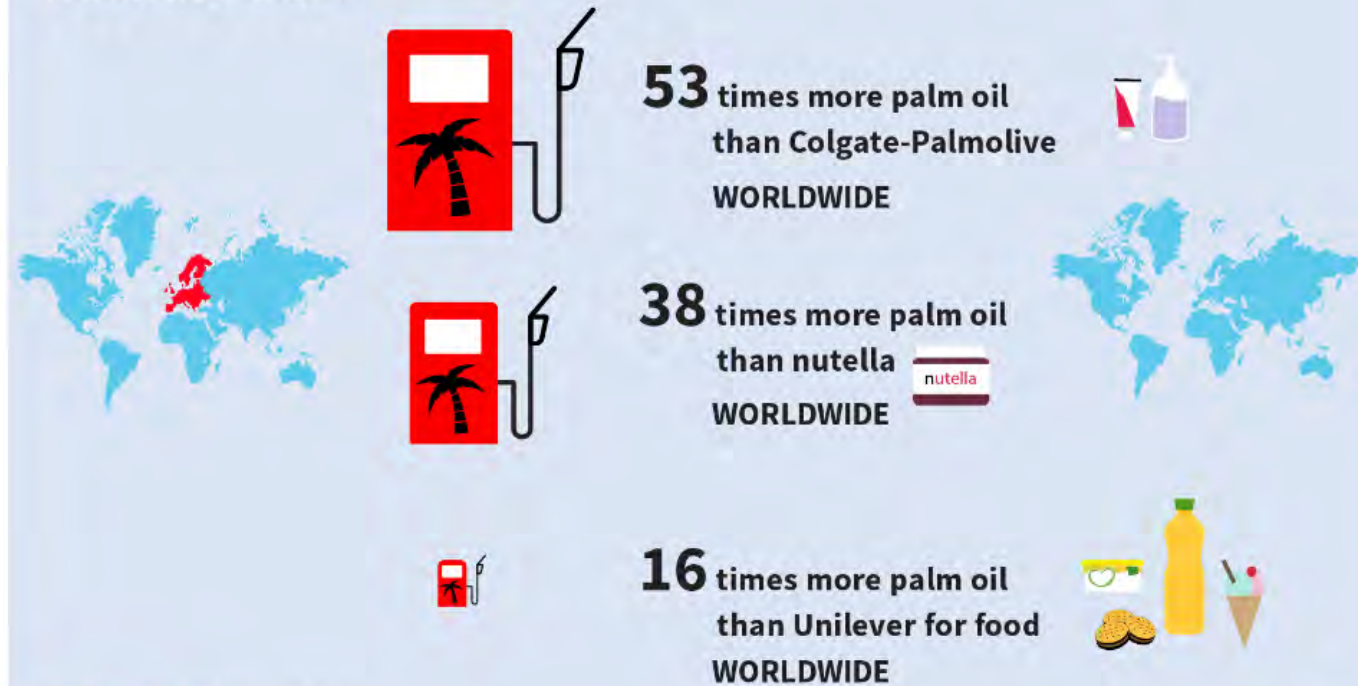

TRANSPORT & ENVIRONMENT
 @transenv @transenv
 transportenvironment.org

Source: T&E

- Palm oil is widely used as fuel in the EU, and has become a political issue!



Co-funded by the
 Erasmus+ Programme
 of the European Union

Fame: Palm oil fuel usage increasing!

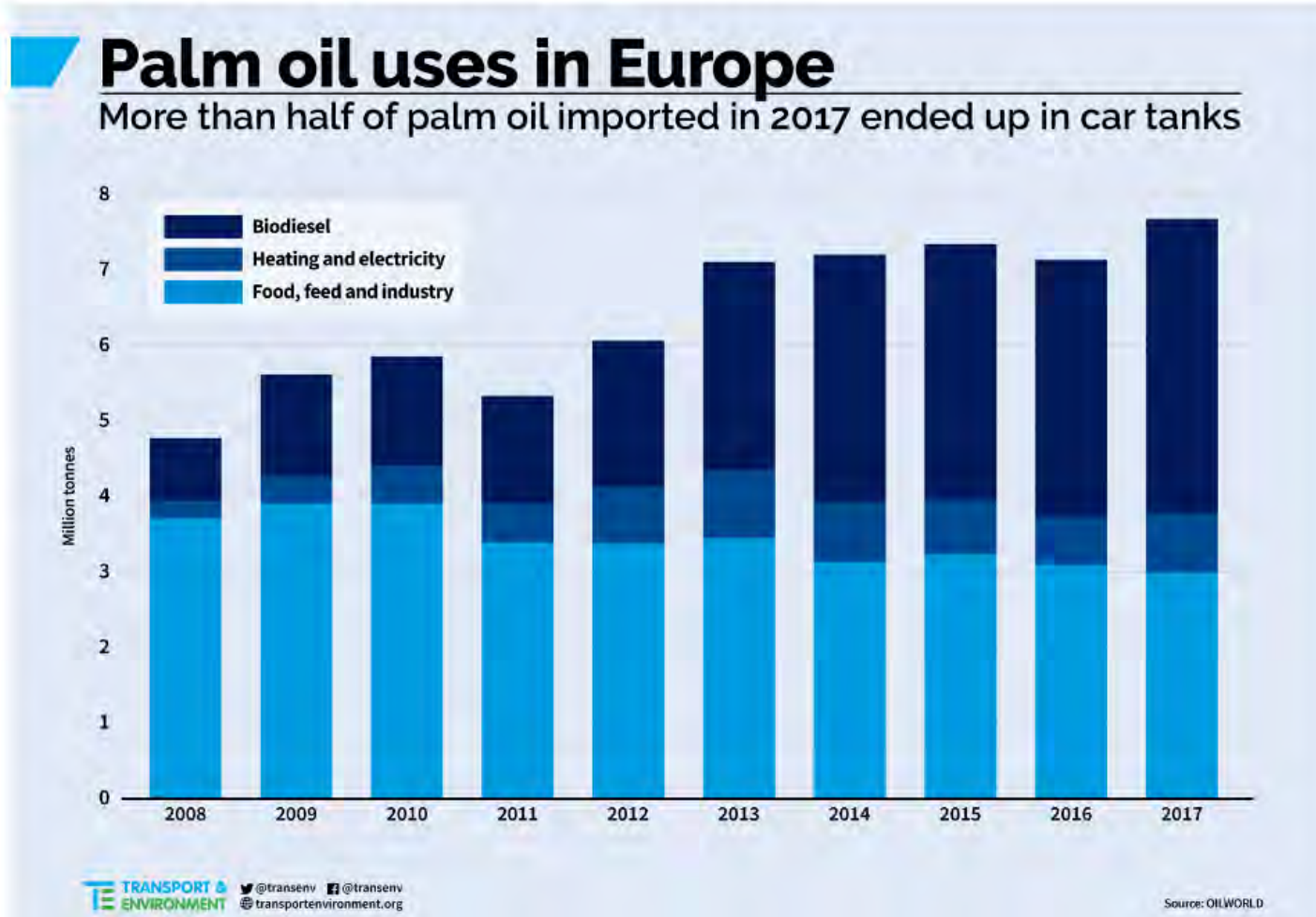

Widely used in EU, palm oil has the following reputation:

- unsustainable
- In competition with rainforest (especially in South America, Indonesia, Malaysia)
- This environmental destruction threatens biodiversity and increases greenhouse gas emissions

Source: Transport and Environment
Square de Meeus, 18
B-1050 Brussels, Belgium
<https://www.transportenvironment.org/what-we-do/biofuels/why-palm-oil-biodiesel-bad>



Ambivalence with Palm Oil I



- Palm oil is the Dr. Jekyll and Mr. Hyde of biofuels. On one hand, palm oil, extracted from the fruit of palm trees, is one of the most energy-efficient [biodiesel](#) fuels on the market.
- [Diesel engines](#) don't have to be modified to run on palm oil biodiesel, and biodiesel from palm oil releases less carbon dioxide into the atmosphere than [gasoline](#).
- Plus, palm oil helps the economies of Malaysia and Indonesia, where most palm tree plantations are located.
- However, the farmers in Malaysia and Indonesia are burning thousands of acres of rainforest each day to make room for more palm plantations. This destruction threatens an already fragile ecosystem and puts thousands of plant and animal species at risk [source: [Brune](#)].

Ambivalence with Palm Oil II

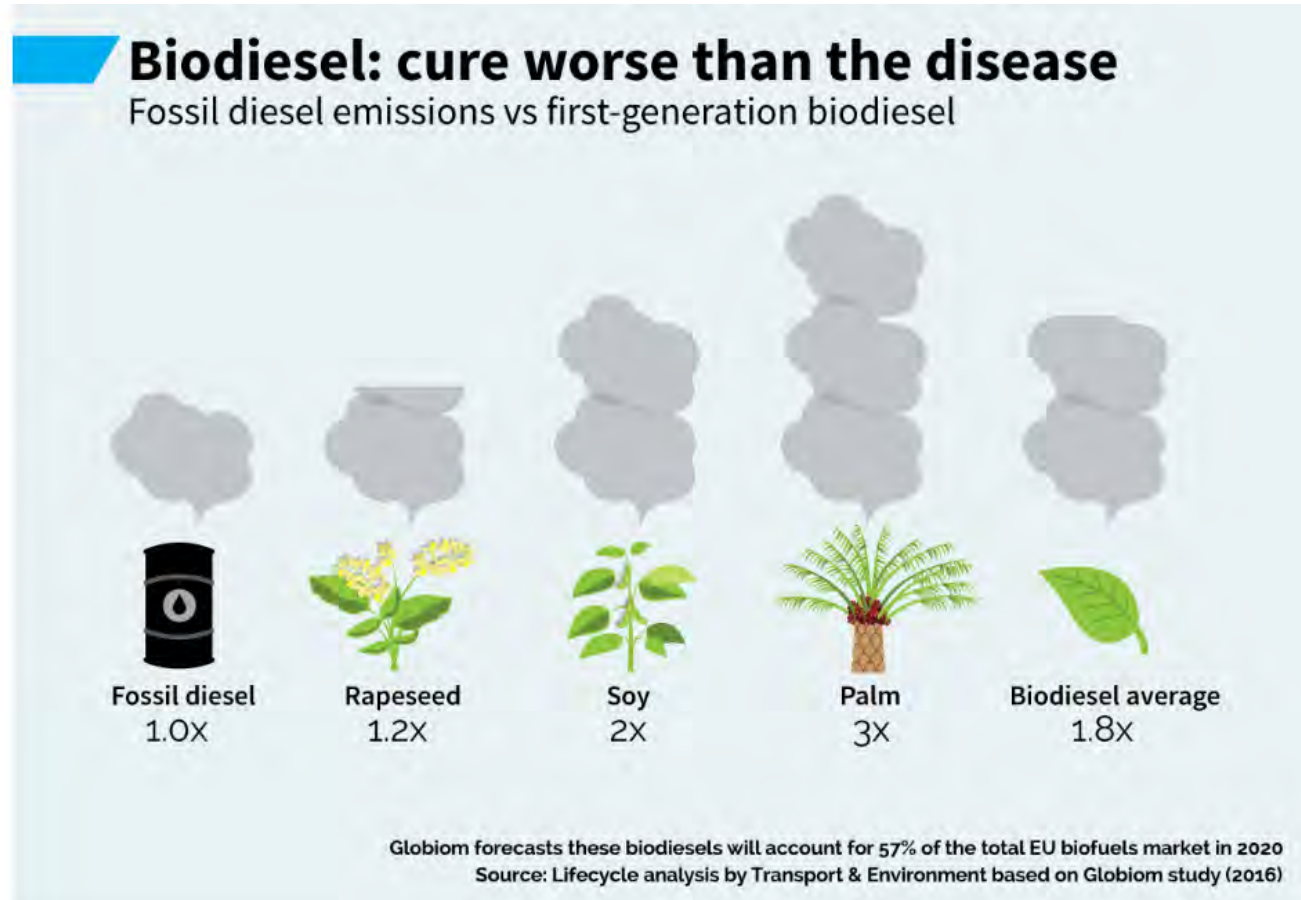

- To satisfy Europe's current thirst for palm oil biodiesel, 4,300,000 hectares of land in the tropics would be needed
- That area is equal to the remaining rainforests and peatlands of Borneo, Sumatra and peninsular Malaysia
- In 1/2018, the European Parliament proposed to end public subsidies for the use of palm oil biofuels in 2021, in 6/2018 it was decided to phase out the support to high CO₂ emitting biofuels such as palm oil by 2030
- Of course the calculation depends on relatively arbitrary chosen factors for changing land use and might be not completely fair to Indonesian countries
- This causes even a „small trade war“ between Indonesian countries and the EU

WWF Video



- <https://www.youtube.com/watch?v=7BRGj0DwYwA>



Co-funded by the
Erasmus+ Programme
of the European Union

Oxynigated Diesel-like Fuels

General Behavior in Engines



- Diesel-like fuels with a higher oxygen content burn very clean (without soot emissions), but also produce more NO_x due to higher local combustion temperatures (which can be compensated by higher EGR rates).
- Ignition delay is reduced too with increasing Cetane number!
- Combustion quality and efficiency is increased!

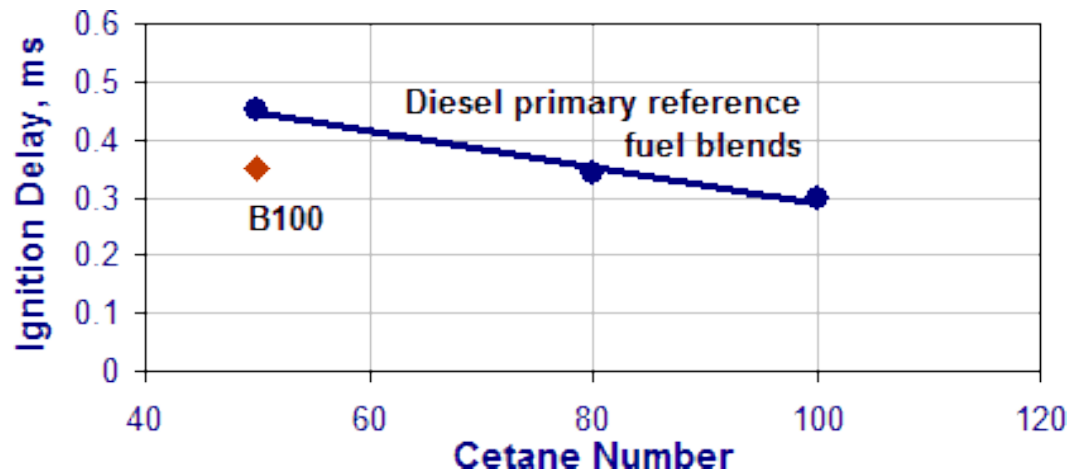

Hydrotreated vegetable oils (HVO), of a similar paraffinic nature, can be produced by hydrotreating plant oils and animal fats.

Liquid, synthetic hydrocarbons



Introduction

Hydrocarbons are organic compounds consisting of hydrogen and carbon. There are many sub-groups: paraffins, such as alkanes, alkenes, alkynes, naphthenes, such as cycloalkanes, and aromatics, such as xylene and benzene, as well as many other related compounds consisting of hydrogen, carbon, nitrogen and sulphur.

Hydrocarbon fuels produced from biomass are called biofuels. When the fuels are produced via extensive processing, such as the xTL routes, they are generically called synthetic fuels.

See page two for Production Process and Applications.

State of the Art

Currently, there is no large-scale production of BtL fuels in Europe. The research project OPTFUEL, led by the Volkswagen Group, aims at demonstrating the production of BtL-based fuels made from wood and wood residues. In the OPTFUEL project fast growing biomass like willow or poplar are used as feedstock. The development of BTL production technology is still in progress and is not yet competitive.

Source:



Co-funded by the Erasmus+ Programme of the European Union

Relevant fuel regulations

EN 590 (diesel fuel)
ASTM D7566 (50% FT fuel in Jet-A1)

FOR EDUCATIONAL PURPOSE ONLY

Molecular Formula

C_xH_y (general), C_nH_{2n+2} (alkanes)

Comparison of Fuel Properties

	BtL **	Diesel
Density at 20 °C [kg/l]*	0.76	0.83
Lower heating value [MJ/kg]*	43.9	43.1
Viscosity at 20 °C [mm ² / s]*	4.0	5.0
Cetane number*	>70	50
Fuel equivalence*	0.97	1
GHG [gCO ₂ eq/MJ]*	n.a.	

Source: FNR 2012. * Median values are used for simplification. Please refer to the standards for ranges. ** Figures based on FT.

in the production of syngas:

- low temperature gasification
- high temperature gasification
- endothermic entrained bed gasification

After gas conditioning the Fischer-Tropsch process is then used to convert the synthesis gas into a crude product which is further processed using hydrocracking into products such as the automotive fuel SunDiesel™.

1. Gasification – to produce raw syngas:

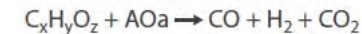

Exact reactions are multifold, e.g. any sulphur becomes H₂S and COS

2. Syngas conditioning – to achieve correct gas quality:



and removal of CO₂, and any H₂S and COS

3. Synthesis via a type Fischer-Tropsch process:



or

synthesis via a Methanol-to-Gasoline process:

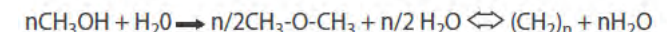
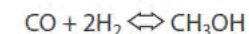

4. Product preparation – to achieve desired properties:

DME Dimethyl ether

Production process

DME is primarily produced by converting natural gas, organic waste or biomass to synthesis gas (syngas). The syngas is then converted into DME via a two-step synthesis, first to methanol in the presence of catalyst (usually copper-based), and then by subsequent methanol dehydration in the presence of a different catalyst (for example, silica-alumina) into DME.

The following reactions occur:



Source:



Relevant fuel regulations

EN 228, EN 15736

Co-funded by the
Erasmus+ Programme
of the European Union

Molecular Formula

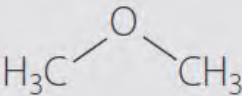

Comparison of Fuel Properties

Property	DME	Diesel
Density at 20 °C [kg/l]*	0.67	0.83
Lower heating value [MJ/kg]*	28.4	43.1
Cetane number*	60	50
Fuel equivalence*	0.59	1
GHG [gCO ₂ eq/MJ]**	Waste wood DME: 5 Farmed wood DME: 7	

Source: FNR 2012. * Median values are used for simplification. Please refer to the standards for ranges. ** Directive 2009/28/EC, total for cultivation, processing, transport and distribution

Introduction

Dimethyl ether (typically abbreviated as DME), also known as methoxymethane, wood ether, dimethyl oxide or methyl ether, is the simplest ether. It is a colourless, slightly narcotic, non-toxic, highly flammable gas at ambient conditions, but can be handled as a liquid when lightly pressurized. The properties of DME are similar to those of Liquefied Petroleum Gas (LPG). DME is degradable in the atmosphere and is not a greenhouse gas.

Applications

Due to its good ignition quality, with a high cetane number, DME can be used in diesel engines as a substitute for conventional diesel fuel. However, compared to diesel fuel DME has a lower viscosity (insufficient), and poor lubricity. Like LPG for gasoline engines, DME is stored in the liquid state under relatively low pressure of 0.5 MPa. This helps to limit the number of modifications required to the engine. Still, some slight engine modifications are necessary, primarily relating to the injection pump and the installation of a pressure tank, similar to that for LPG. The fuel line must also be adapted with specific elastomers.

DME in diesel engine burns very cleanly with no soot.

The infrastructure of LPG can be used for DME. As part of the FP7 project BioDME, under the leadership of the Volvo Group, DME production is being optimized, especially for use as a transport fuel.



DME Dimethyl ether



The following reactions occur:

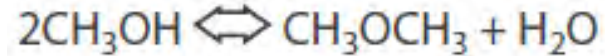

State of the Art

The DME demonstration plant in Piteå, Sweden, which was put into operation in 2010, is the only gasification plant worldwide producing high-quality synthesis gas based on 100% renewable feedstocks. The raw material used is black liquor, a high-energy residual product of chemical paper and pulp manufacture which is usually burnt to recover the spent sulphur.



BioDME plant with DME log truck in foreground © Chemrec 2011

Major stakeholders

Volvo Group, Sweden

Chemrec, Piteå, Sweden

Haldor Topsøe, Kgs. Denmark

Preem, Sweden

Total, France



Co-funded by the
Erasmus+ Programme
of the European Union

Source:



European Biofuels
TECHNOLOGY PLATFORM

E-Fuels – the (long term) solution??

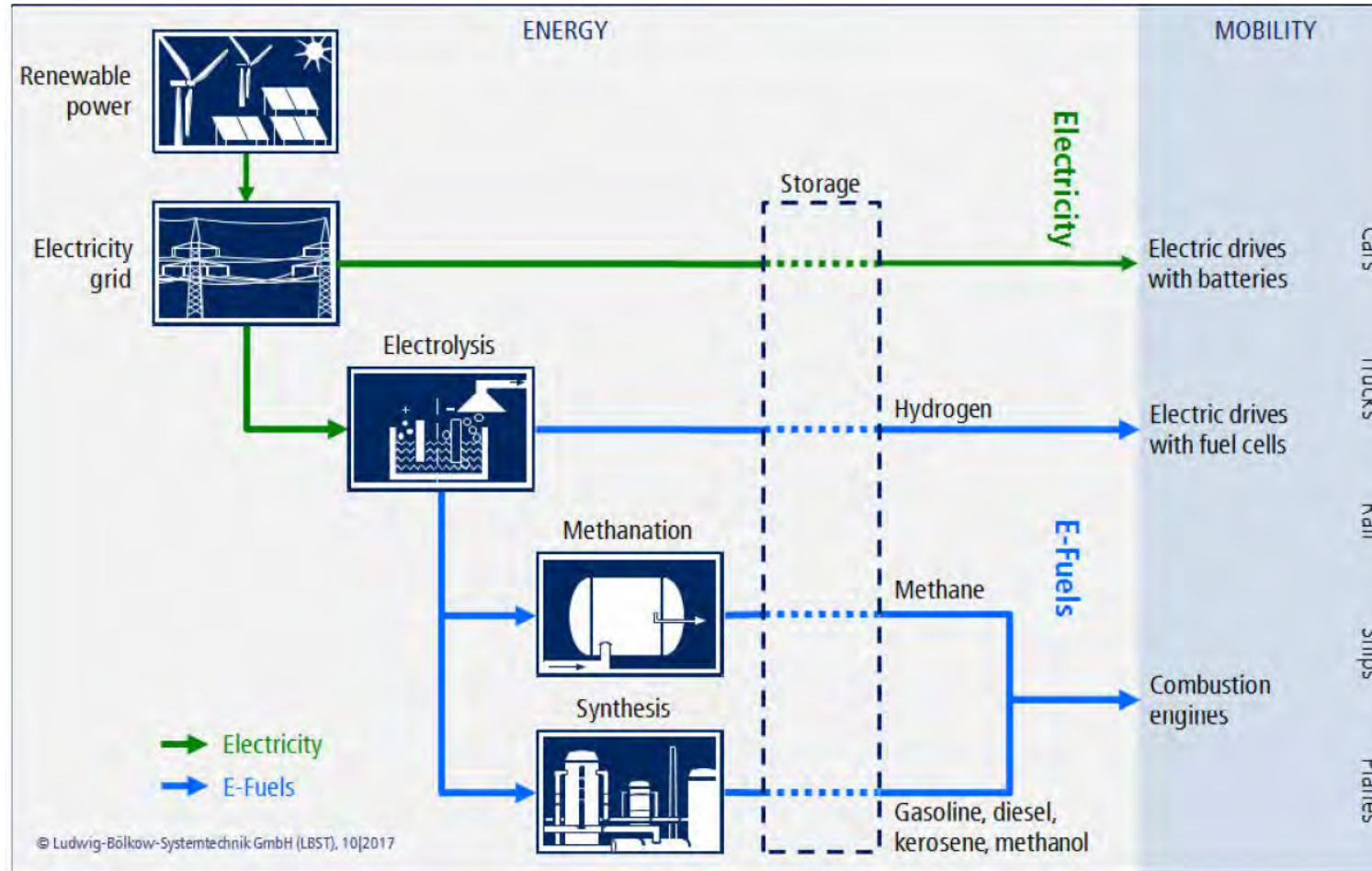

Co-funded by the
Erasmus+ Programme
of the European Union

Synthetic Fuels – E-Fuels

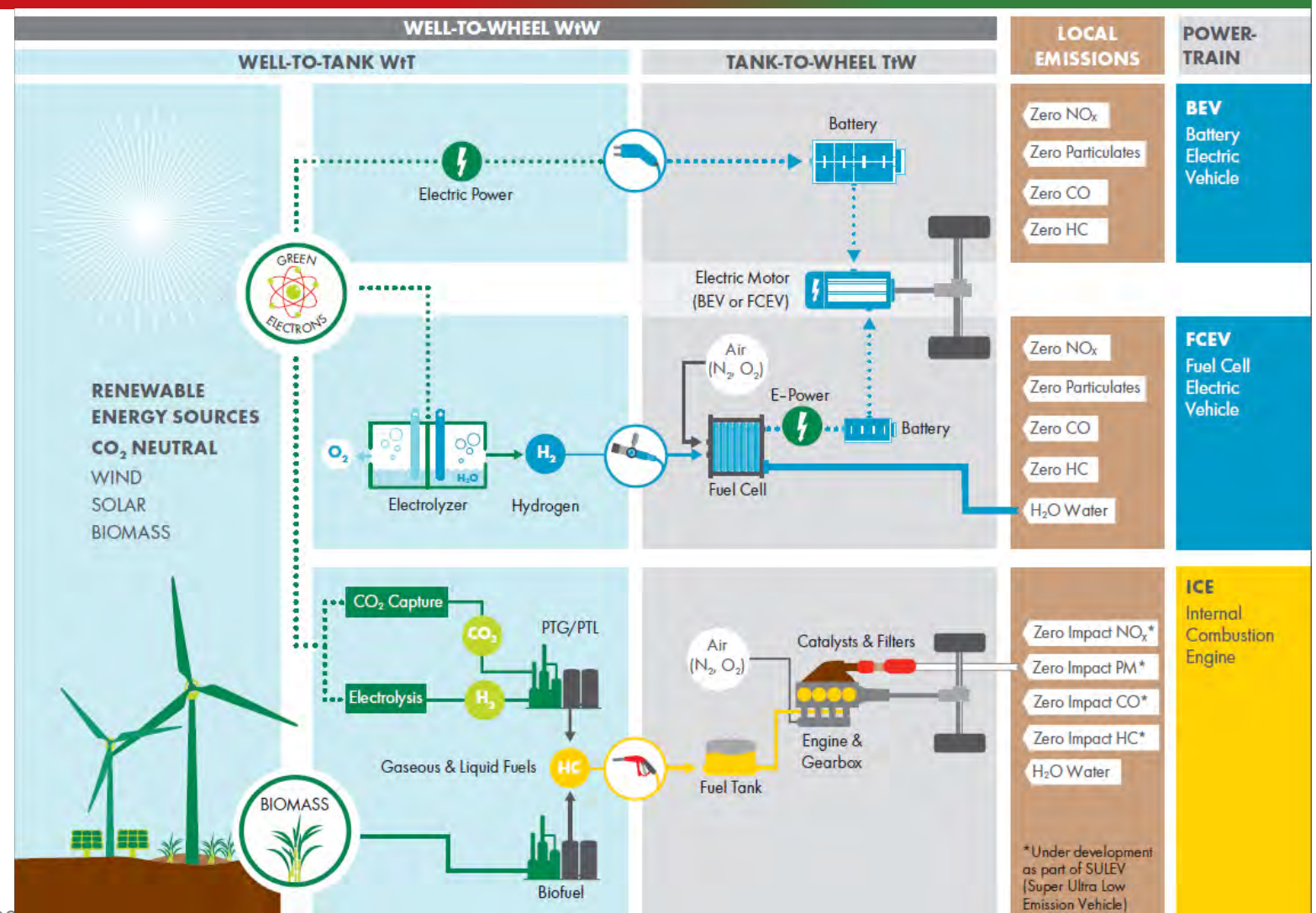

Source: The road to sustainable fuels as basis for Zero Emission Mobility 2018 Vienna Engine Symposium, Shell Warnecke et.al & ÖVK Publication Pdf: 2018_roadtoZEm_Warnecke_Shell_ÖVK.pdf



Power to Liquid – Energy required

4 RESOURCES REQUIRED FOR POWER-TO-LIQUIDS PRODUCTION

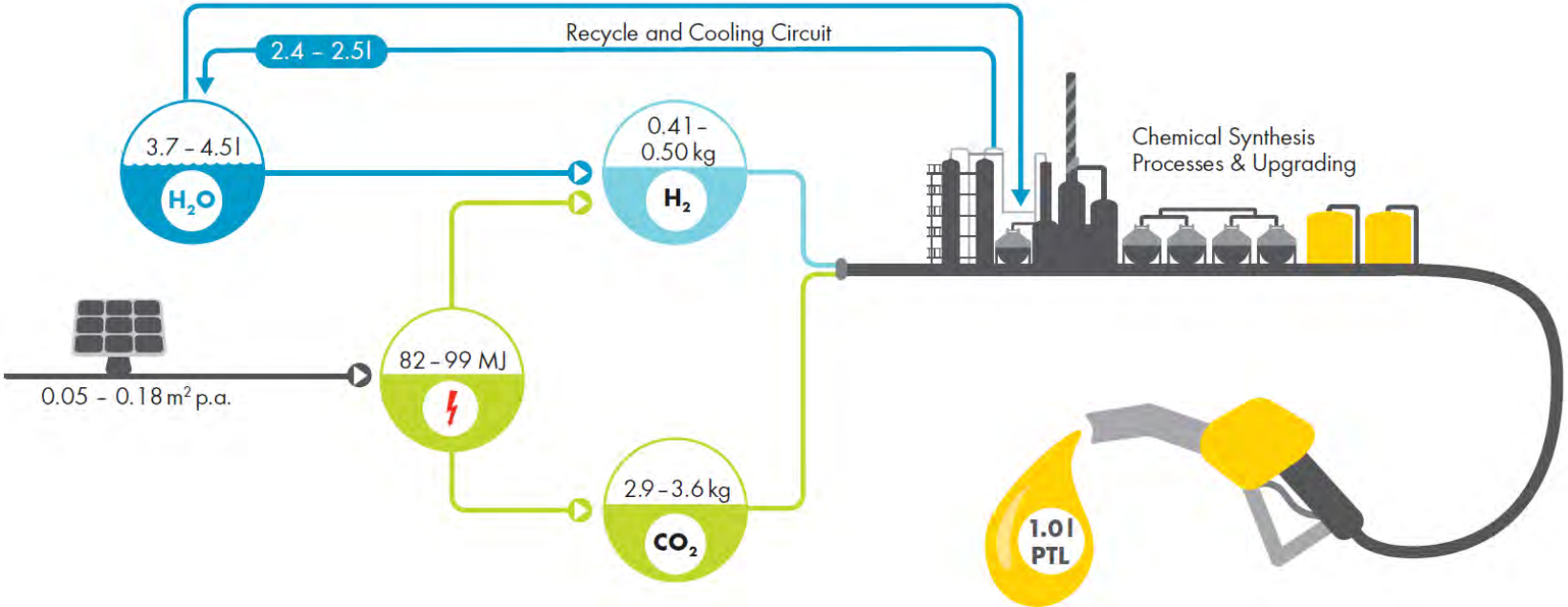

Average amounts of energy and feedstock needed to produce 1 litre of an average PTL fuel (decane), which could be either diesel (FT route) or gasoline (methanol route). Efficiencies are those of a PTL plant in 2030. Synthesis processes comprise Reverse Water-Gas Shift and Fischer-Tropsch steps or Reverse Water-Gas Shift, Methanol Synthesis and Methanol-to-Gasoline steps. Upgrading is included.

Synthetic Fuels – E-Fuels



- **E-Fuels** are synthetic fuels, which are produced via electricity out of water and CO₂ => Power-to-Fuel
- This technology can produce gaseous (**Power-to-Gas**, PtG) or liquid (**Power-to-Liquid**, PtL) fuels
- If the electricity is produced by renewable sources (i.e. wind, photovoltaic etc) and the CO₂ is taken from the atmosphere, then this fuel can be called „**climate neutral**“ or „**Zero Impact Fuel**“
- DME (Di-Methyl-Ether) is a promising synthetic fuel produced from fossil or biomass resources via gasification (synthesis gas), requiring moderate engine modifications.
- Advantages of E-fuels over E-Mobility are that the infrastructure need not be changed and that ice engines are highly developed and reliable
- Disadvantage of E-Fuels are the **high costs for production and the low efficiencies** involved, – they are currently not economical feasible
- Per km cars fueled by E-Fuels need double times electricity compared to fuel cell cars and five times more than battery electric vehicles
- First applications could be seen in air and marine transport, rather than in passenger cars



Hydrogen



Running on hydrogen and air, emitting water....

The ultimate solution???

Hydrogen – Fuel Station



Co-funded by the
Erasmus+ Programme
of the European Union

Source: https://www.123rf.com/photo_8833700_close-up-of-gas-pump-nozzles-at-a-gas-station-.html

FOR EDUCATIONAL PURPOSE ONLY

“Conventional” Fuels for engines

Overview and comparison

	Gasoline	Diesel	Comp. Natural Gas LNG	Methan CH4	Liquid gas LPG: 50/50 Propan/Butan	Hydrogen H2
Hu [MJ/kg]	42	41,5	48,8	50	45,8	120
H _{meas} [MJ/m3], 20°C, λ=1	3,45	3,87	3,18	3,22	3,73	2,97
Density liquid [kg/m3]	730-780	820-850	440	424	540	71
Density gas [kg/m3]			0,73	0,72	2,06	0,09
Density @ 20 MPa [kg/m3]			170			
Tboil [°C]	30-190	170-350	-162	-162	-30	-253
L _{stöch} [kg/kg]	14,7	14,5	17	17,2	15,5	34
C-Cont. [Weight%]	86	86	73	75	82	0
CO ₂ in Exhaust [g/MJ]	75	74	62	63	65	0
ROZ	92-98		120-130		100	
MZ			98	100	18	0
Cetan No.		45-50				

HYDROGEN EXAMPLE:

- **Lower heating/calorific value (Hu):** ~ usable energy content of a fuel, in this case around 120 MJ/kg or **33 kWh/kg** (> 3x gasoline!)
- **Density liquid (>-253°C) :** 71 Kg /m3
- **Density gas:** 0.09 Kg/m3
- **Boiling temperature:** - 253°C
- **Stoichiometric ratio (Lstöch)** mass of air an fuel required for combustion: **34 Kg/Kg**
- **Passenger car storage standard:** 70 mPa¹⁵

Fuels for vehicles - Hydrogen

The most promising long term solution may be **hydrogen**:

- producing it by renewable sources you **stabilize their intrinsically instable output** and have **CO₂ free energy storage**
- **many fields** of direct H₂ applications
 - Transports (cars, trucks, trains..)
 - Agriculture (Ammonia synthesis)
 - Heating (gas synthesis)
 - Industry (metal production)
 - Electric energy supply (via Fuel Cells) for static applications
- **well known technology**
- main obstacles are the **lack of diffused infrastructures** and still **high costs** for both producers and users

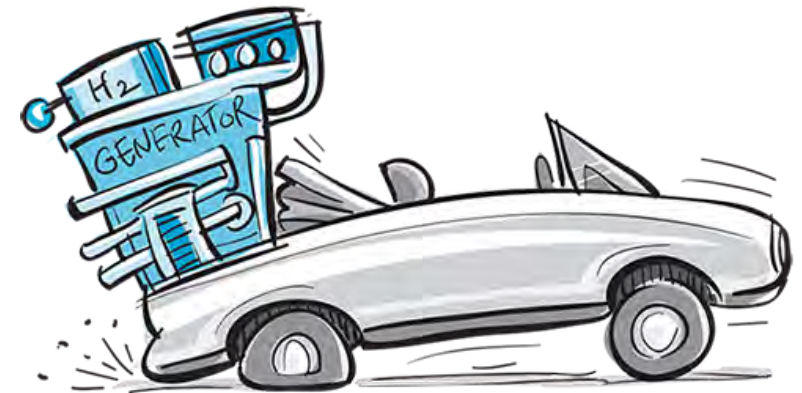

Sources:

- <https://cafcp.org/faqs>
- <https://openbudgetsindia.org/group/agriculture>
- <https://www.tra.gov.au/Economic-analysis/state-of-the-industry>



Fuel cell applications by power level

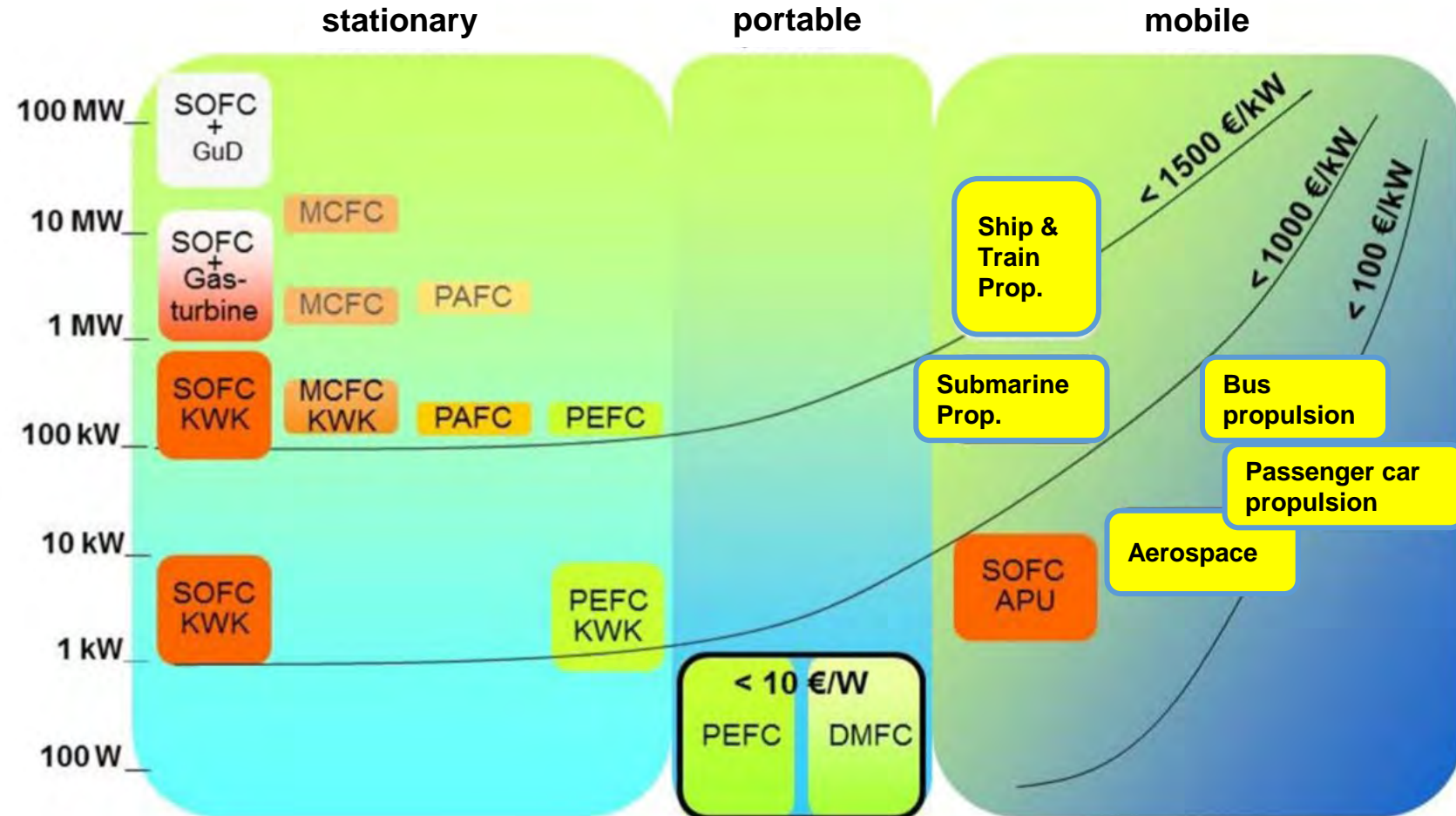

Hydrogen Well to Tank (WtT)

- ~30 Fuel production path shown
- Efficiency and energy for production varies a lot
- Most economical path is from natural gas reforming (no CO₂ reduction, still fossil!), to be avoided!
- From renewable electricity (electrolysis) decentralized production is possible (everywhere!).

W2T Hydrogen Production Paths or W2W Balance for H₂ Application in FCV



Hydrogen in ICE -a solution for ships?



Source: R&D EU Project HyMethShip



Co-funded by the
Erasmus+ Programme
of the European Union

Partner Companies in R&D Project HyMethShip

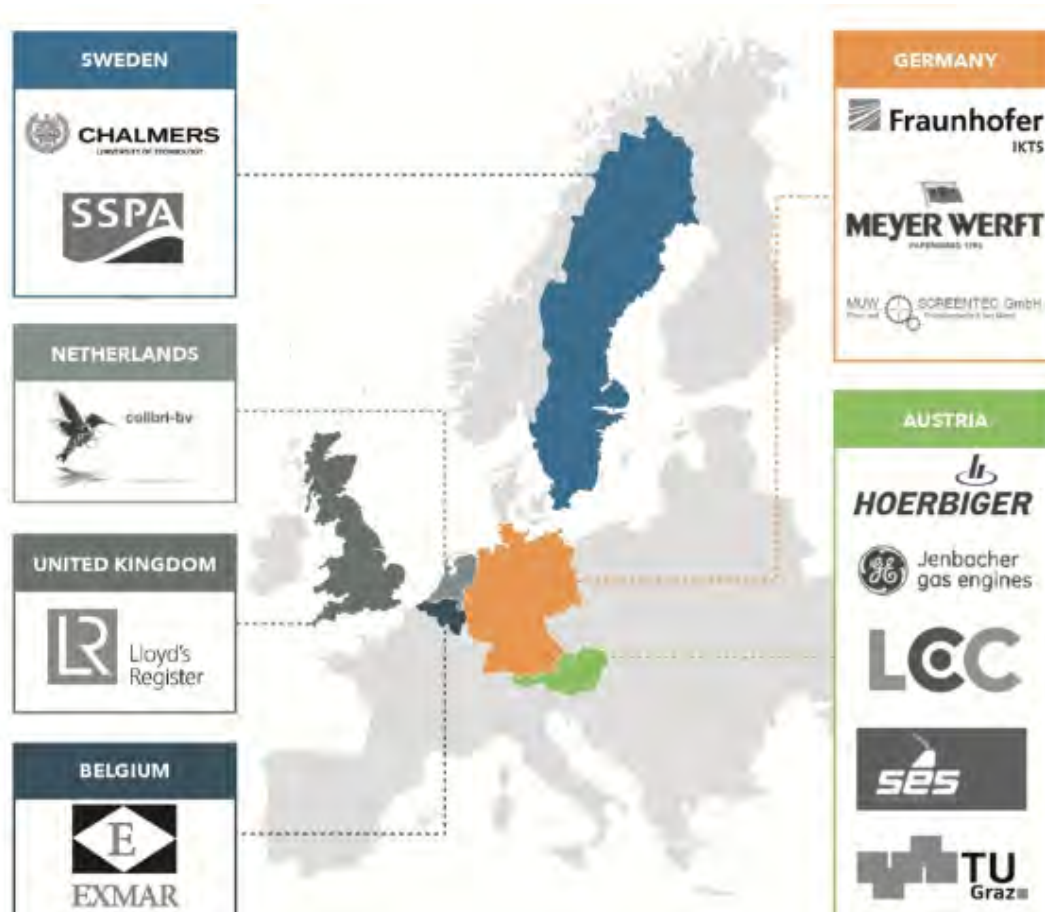

Partner overview:

- LEC GmbH (Projektkoordinator)
- GE Jenbacher GmbH & Co OG
- Fraunhofer IKTS
- Chalmers Tekniska Hoeskola AB
- SSPA Sweden AB
- Lloyd's Register IMEA IPS
- SE.S
- Colibri bv
- Exmar Marine NV
- Technische Universität Graz
- MUW Screentec GmbH
- MEYER WERFT GmbH & Co. KG
- HOERBIGER Ventilwerke GmbH & Co OG



Co-funded by the Erasmus+ Programme of the European Union

HyMethShip Project

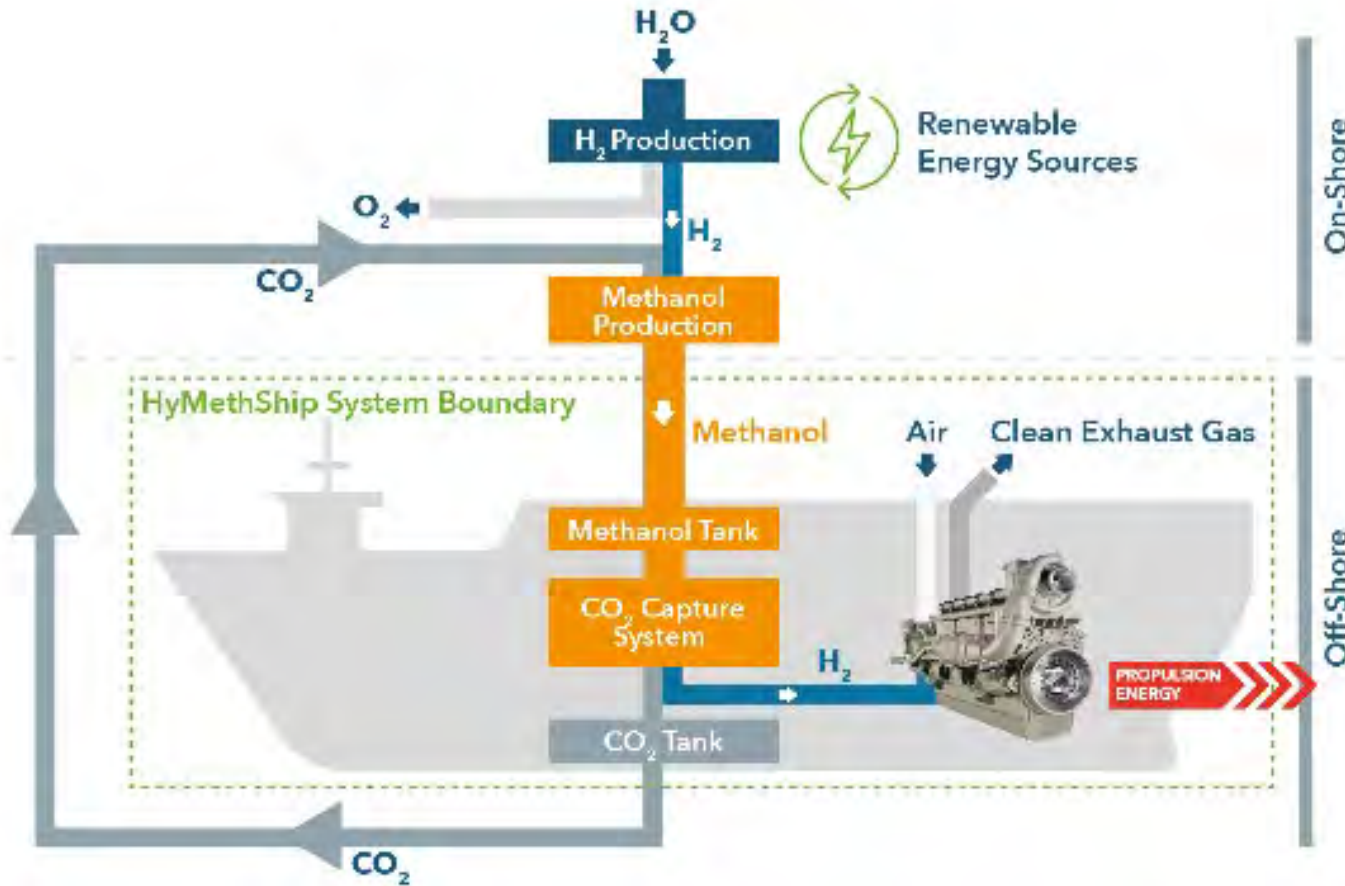

- Burning H₂ in the engine results in almost carbon free emission (only oil residues)
- CO₂ in a closed loop
- But still: NO_x emission (reduced by heavy EGR)!!!



Co-funded by the
Erasmus+ Programme
of the European Union

Electricity and Hydrogen - Summary



- Electricity and hydrogen are universal energy carriers and can be produced from all primary energy sources.
- Both pathways can in principle be made CO₂ free; the CO₂ intensity depends on the energy mix for electricity and hydrogen production. Propulsion uses electric motors. The energy can be supplied via three main pathways:
 - Battery-electric**, with electricity from the grid stored on board vehicles in batteries. Power transfer between the grid and vehicles requires new infrastructure and power management. Application is limited to short-range road transport and rail. The development of cost competitive high energy density batteries and the build-up of charging infrastructure are of the highest priority.
 - Fuel cells powered by hydrogen**, used for on-board electricity production. Hydrogen production, distribution and storage require new infrastructure. Application is unlikely for aviation and long-distance road transport. The development of cost-competitive fuel cells, onboard hydrogen storage, and strategic refuelling infrastructure is of the highest priority.
 - Overhead Line / Third Rail** for tram, metro, trains, and trolley-buses, with electricity taken directly from the grid without the need of intermediate storage.



Fuels for engines - Conclusions

Focus on renewable fuels for ice's



The use of renewable fuels in internal combustion engines allows for a

- A significant reduction of GHG emission reduction (down to CO₂ neutral mobility) with the existing car fleet
- The considered fuels are either based on biomass only or combine hydrogen from renewable electricity with a carbon source through a PtX technology
- Renewables can directly replace fossil fuels in road transport and common internal combustion engines and existing infrastructure require only little to no adjustments
- Further research needed towards increased efficiency and zero impact emissions
- Depending on the GHG emissions from the production pathway, renewable fuels can be more efficient and environmentally friendly than systems with all electric power trains, and additionally offer the further advantage that they can be used in the existing infrastructure
- In the long term, even beyond 2050, optimized combustion engines will still be needed and applied in power trains of heavy passenger cars, hybrid utility vehicles (e.g. in heavy duty or long-distance road transportation), trains, ships and airplanes as well as in stationary applications

Conclusion from an engine engineer's point of view



- Although politicians want to get rid of ICEs, they are proven, reliable and relatively cheap machines and using alternative bio based fuels can make them CO₂ neutral, which could guarantee their survival in times of global warming.
- Almost anything that burns and is liquid or gaseous can be filled in combustion engines and will work in principle. Differences mainly occur in ignition delay, combustion speed (rate of heat release) and (minor) differences in emission behavior.
- Changes are definitely necessary in the application of engine parameters such as injection timing, ignition (timing), exhaust gas recirculation, aftertreatment systems, etc. But this is just APPLICATION WORK! “Drop-In Fuels” (without changes to the engine) have a market share ~ 2-3% and so currently minor impact.
- Changes might be necessary to tank systems, valves and sealings (chemical robustness against aggressive fuels)

General Conclusion



- Introducing alternative fuels to internal combustion engines is technically no major problem – all issues can be solved
- Alternative fuels are **an economical issue**: production and treatment energy costs; investments in infrastructure;
- Alternative fuels are **a political issue**:
 - How serious is the political will to avoid fossil fuels and
 - Will they cope with Paris CO₂ targets
 - Are politicians are willing to accept CO₂ neutral fuels or are they heading for electricity only
- Changes are definitely necessary in politics:
 - Financial support for investments in production, distribution and infrastructure
 - Subsidies for compensating higher prices for end consumers



Fuels for engines

Discussion



A few questions:

- **Give me an instant feedback on the content!**
- **How is the attitude in your area/university on alternative fuel?**
- **How can we make students interested in this topic of alternative fuels?**
 - Do you have engine labs/infrastructure that you can also test the effects of different fuels in your engine labs?
 - Can you do engine experiments with different fuels for comparison reasons?
- **Learning targets for students in “alternative fuels”**
 - Get an Overview about all possible fuel alternatives
 - Understand the different pros and cons for each fuel possibility
 - Understand technical, societal and environmental impact
 - Find a specific solution for your country





Engineering Knowledge Transfer Units to Increase Student's Employability and Regional Development



<https://www.facebook.com/unitederasmus/>



Co-funded by the
Erasmus+ Programme
of the European Union

This project has been funded with support from the European Commission. This publication reflects the views only of the author, and the Commission cannot be held responsible for any use which may be made of the information contained therein.
598710-EPP-1-2018-1-AT-EPPKA2-CBHE-JP

FOR EDUCATIONAL PURPOSE ONLY



Engineering Knowledge Transfer Units to Increase
Student's Employability and Regional Development

Options for a CO₂ reduced Mobility

ICE / Electric Hybrid Powertrain



Co-funded by the
Erasmus+ Programme
of the European Union

This project has been funded with support from the European Commission. This publication reflects the views only of the author, and the Commission cannot be held responsible for any use which may be made of the information contained therein.
598710-EPP-1-2018-1-AT-EPPKA2-CBHE-JP

FOR EDUCATIONAL PURPOSE ONLY

Future diversification of Powertrains

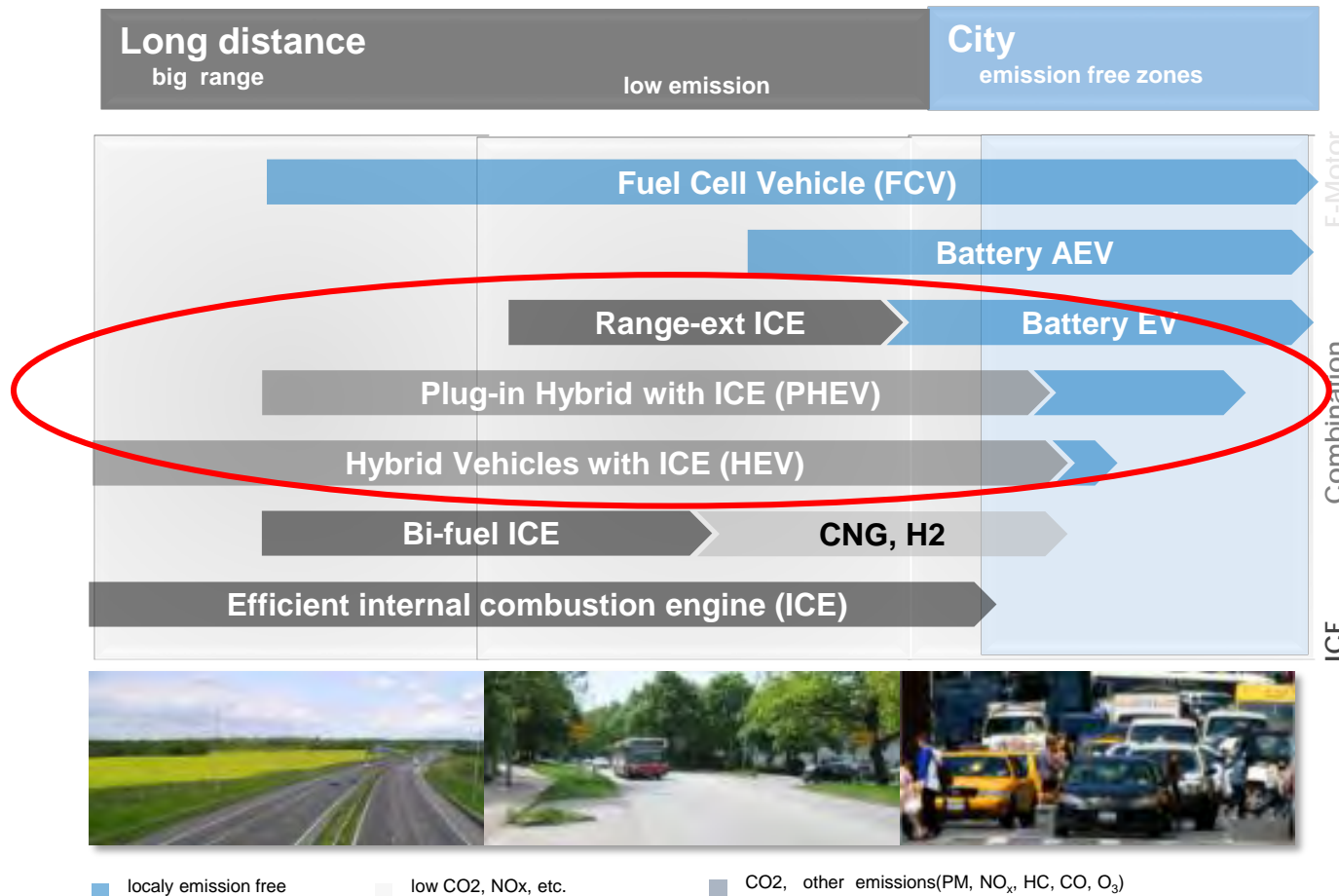

Diversification of powertrains and fuels to fulfil CO₂ legislation

- ### Advanced powertrains
- High Engineering demand
 - New Components & Systems
 - Electrification need battery systems with high energy density
 - CNG and hydrogen need high pressure gaseous storages



■ locally emission free ■ low CO₂, NO_x, etc. ■ CO₂, other emissions (PM, NO_x, HC, CO, O₃)

Electrification of PWT

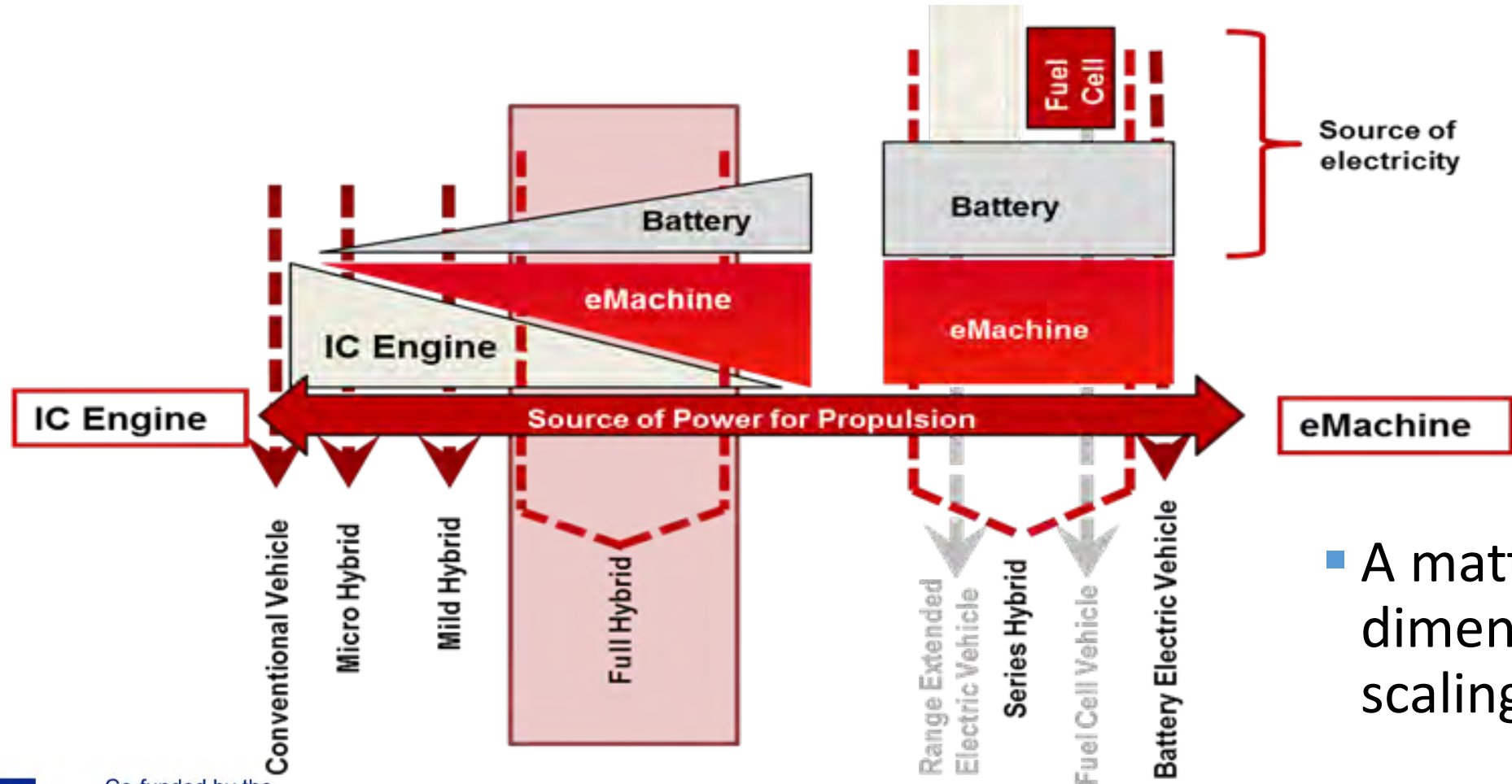

- A matter of dimensioning and scaling!

EU Legislation promotes Hybridization

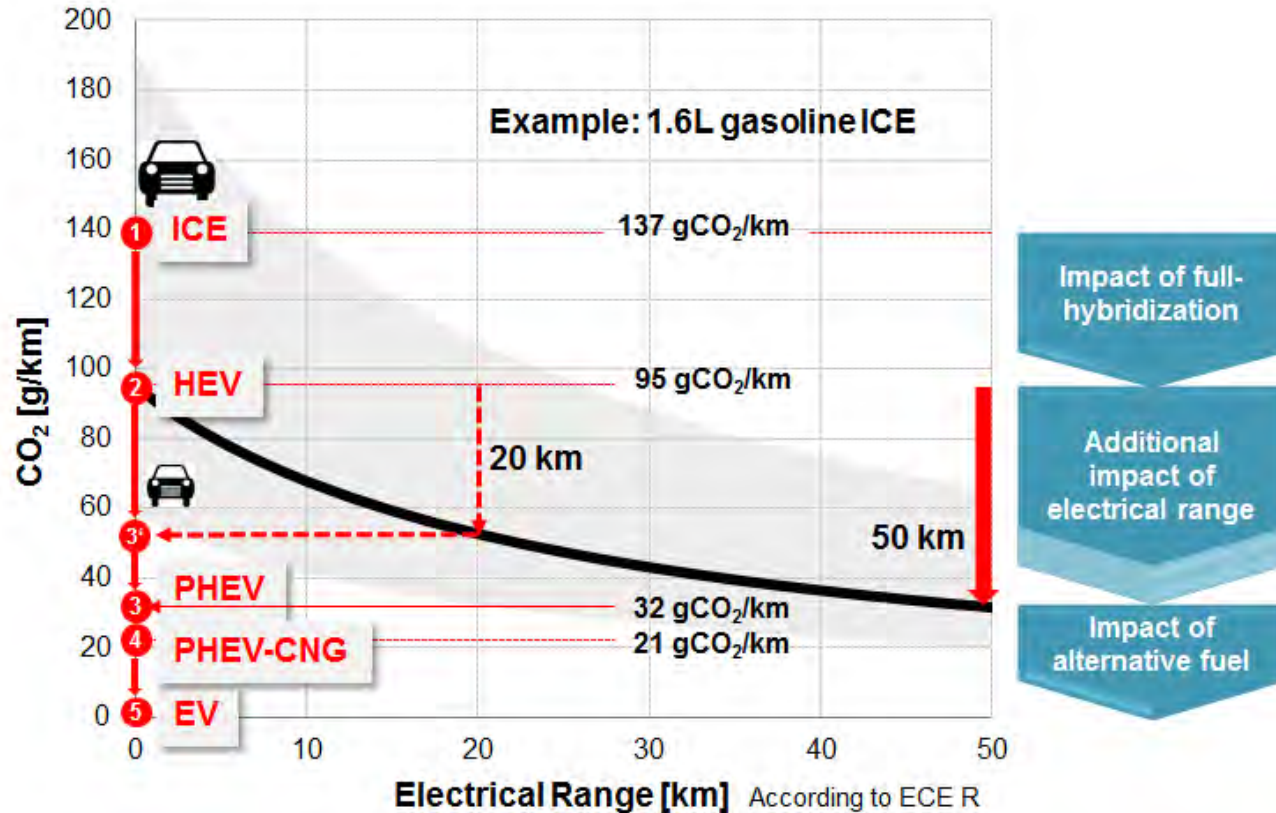

According to ECE R 101:

$$M = (D_e \cdot M_1 + D_{av} \cdot M_2) / (D_e + D_{av})$$

M...mass emission of CO₂ [g/km]

M₁...CO₂ [g/km] with a fully charged electrical energy/power storage device

M₂...CO₂ [g/km] with maximum discharge of storage device capacity

D_e...vehicle's electric range

D_{av}...25km (assumed average distance between two battery recharges)

- CO₂ discount depending on electrical range
- No benefit for too big batteries
- Suitable especially for commuting
- Increasing acceptance of electrification

Hybrid – Powertrain I - Pros



**Hybrid drive =
Combination of combustion engine and electric powertrain :**

Arguments for hybrid vehicles:

- Emission free range in city environment
- Fuel consumption reduction in city driving (up to 30%)
- Additional functions such as start/stop, recuperation of brake energy
- Big, usual range and transport capacity
- Universal usability in all traffic zones
- smallest possible ice-emissions in hybrid mode
- Reduced dependency from battery (no range anxiety/no low battery syndrom)
- Using existing infrastructure
- Higher end customer acceptance

Hybrid – Powertrain II - Cons

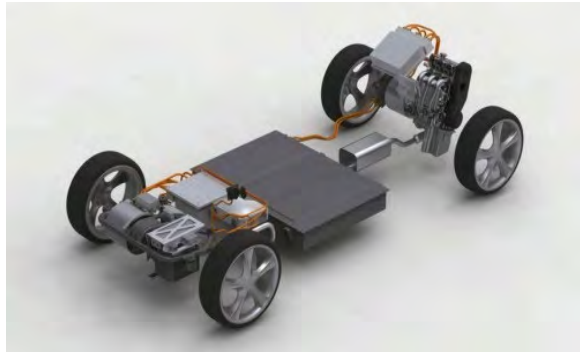

**Hybrid drive =
Combination of combustion engine and electric powertrain :**

Arguments against hybrid vehicles:

- High production costs and complexity
- Weight increase and space requirements especially for batteries
- High effort in the control for both drives
- No fuel consumption reduction in higher speeds
- High development status and quality required for market entry
- Does not solve the principal problem of fossil fuel consumption and CO₂

>> Hybrid powertrain combines advantages and disadvantages of both drives!



Co-funded by the
Erasmus+ Programme
of the European Union

Hybrid – Powertrain - Torque potential

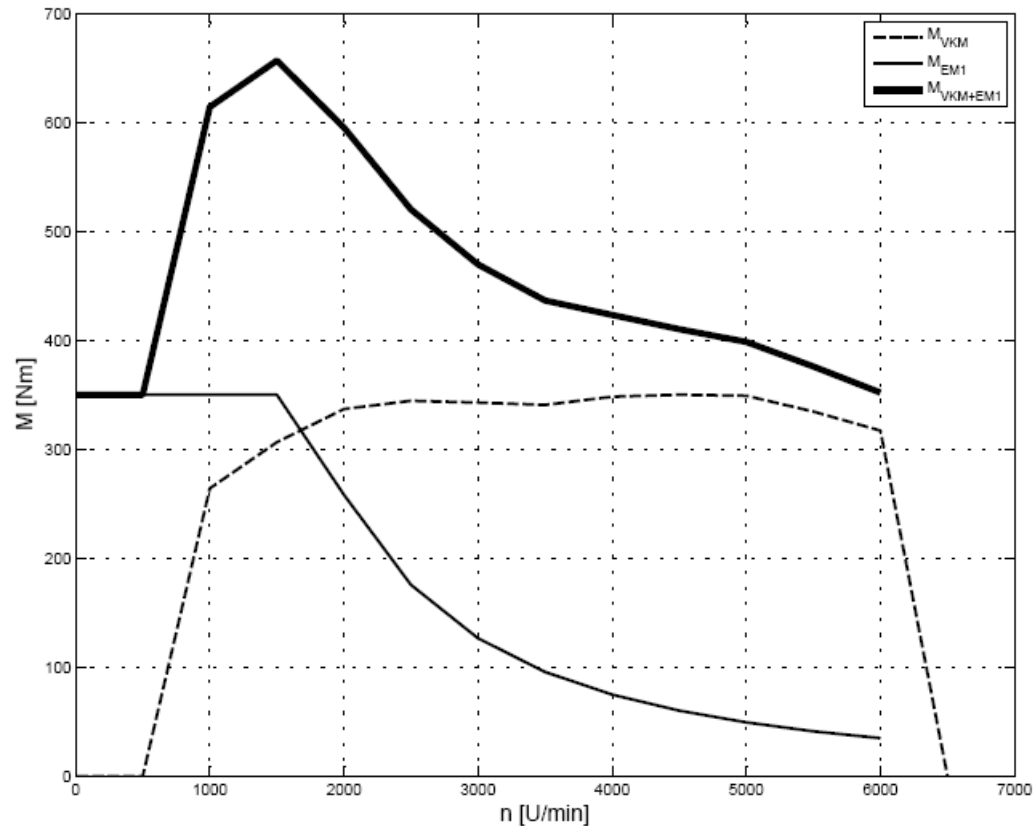

- The combination of both drives offers also a high power potential:
- „Power-HEV“ with big fun to drive“
- The torque characteristics of both drives can be added!



Hybrid – Powertrain Efficiency Evaluation



Hybrid powertrains offer additional degrees of freedom compared to the conventional and pure electric drives.

The powertrain efficiency depends on:

- selected hybrid architecture,
- efficiency of components,
- and the chosen operating strategy (new!).

Evaluation / „Common sense rules“

1. Any energy-transformation causes losses
2. (in-between) Storage of energy causes losses too
3. Operating big components in part load is not efficient



Co-funded by the
Erasmus+ Programme
of the European Union

Hybrid – Powertrain Classification



Hybrid architectures:

- **Series- Hybrid**
- **Parallel-Hybrid**
- **Power Split / mixed or structure-variable hybrid drives**

Hybrid power:

- **Micro - Hybrid (improved alternator/generator combination, 2-5 kW)**
- **Mild - Hybrid (app. 10-15 kW E- Motor, Voltage level 12V , 48 V, but below 200 V)**
- **Full - Hybrid (E-Motor > 15 kW, bigger energy storage; Voltages 150 to 800V)**

Charging strategy of the battery: „Autarkic“ or „Plug-In“ Hybrid



Hybrid – Basic Architectures

Series-Hybrid

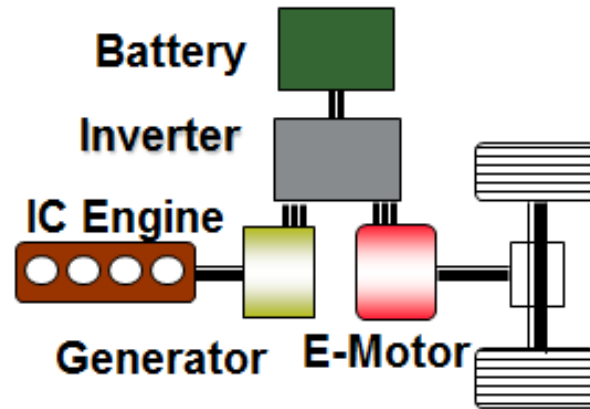

Parallel-Hybrid

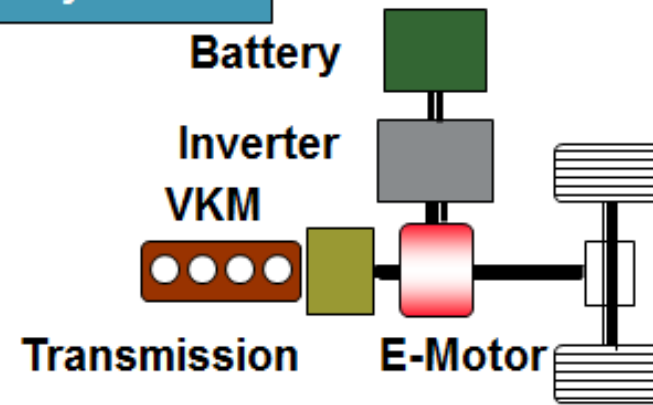

Power Split Hybrid

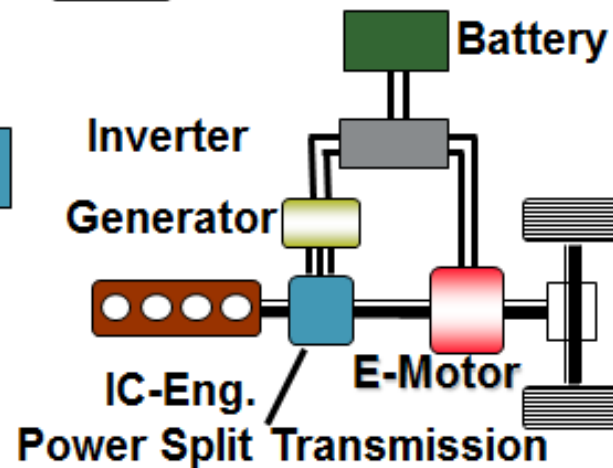

Hybrid vehicle architectures – “Series Hybrid!”



Key characteristics:

- No mechanical connection between ICE and final drive
- ICE powers generator at high efficiency load points
- Traction motor is supplied with electrical power from battery and/or generator

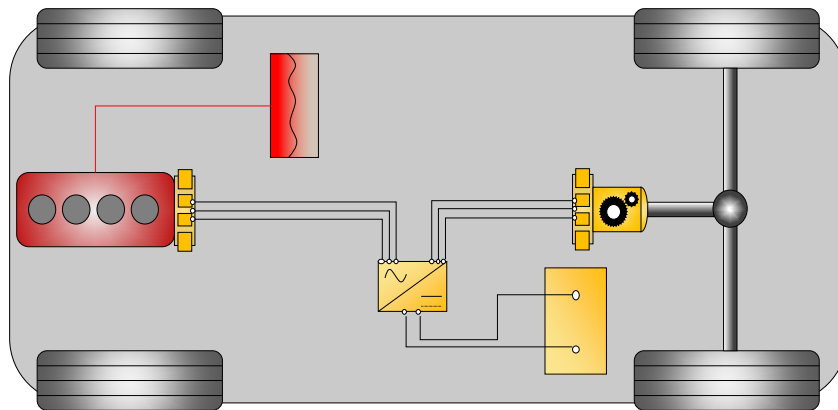

Series Hybrid



Fisker Atlantic



Series hybrid

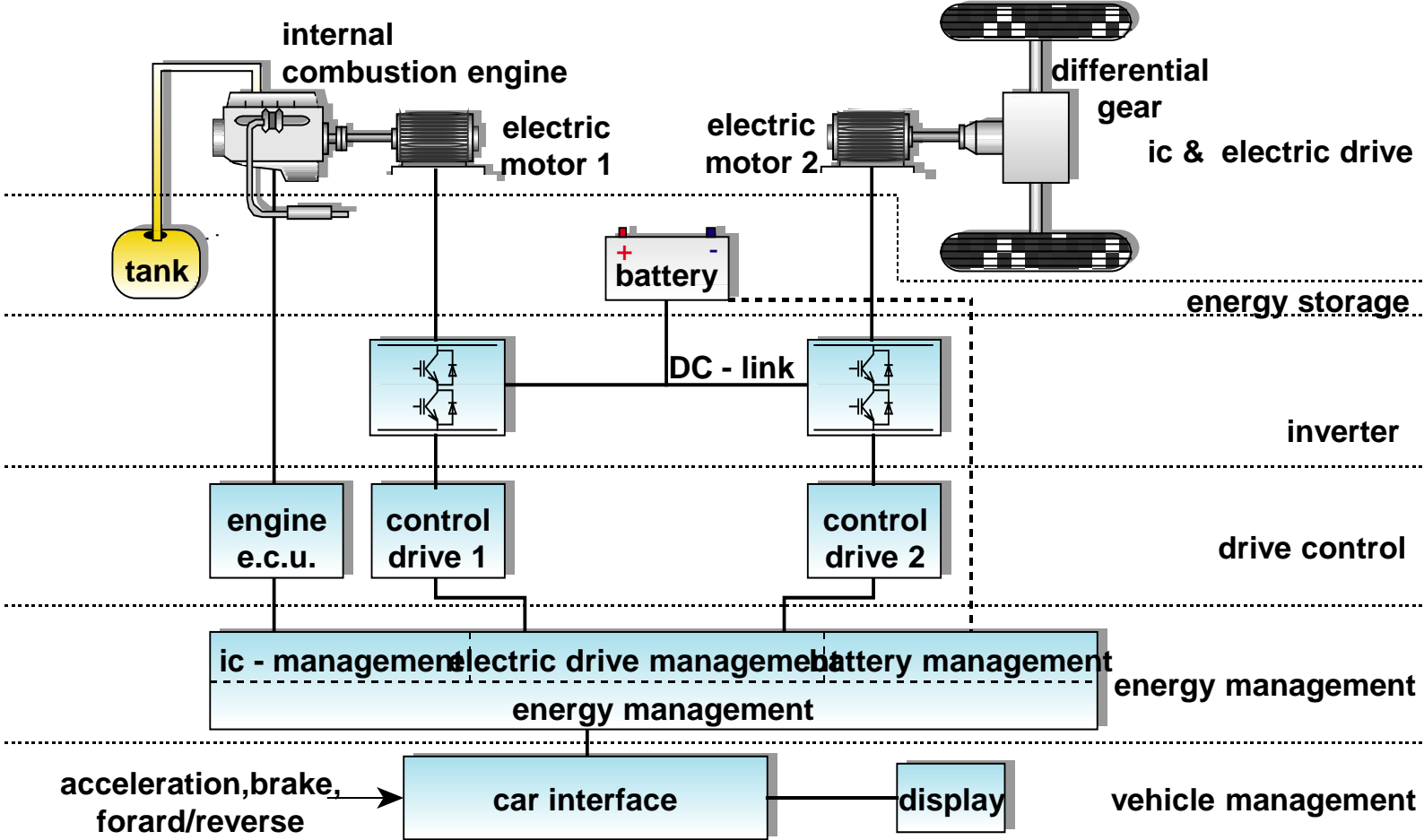

Efficiency chain with series hybrid

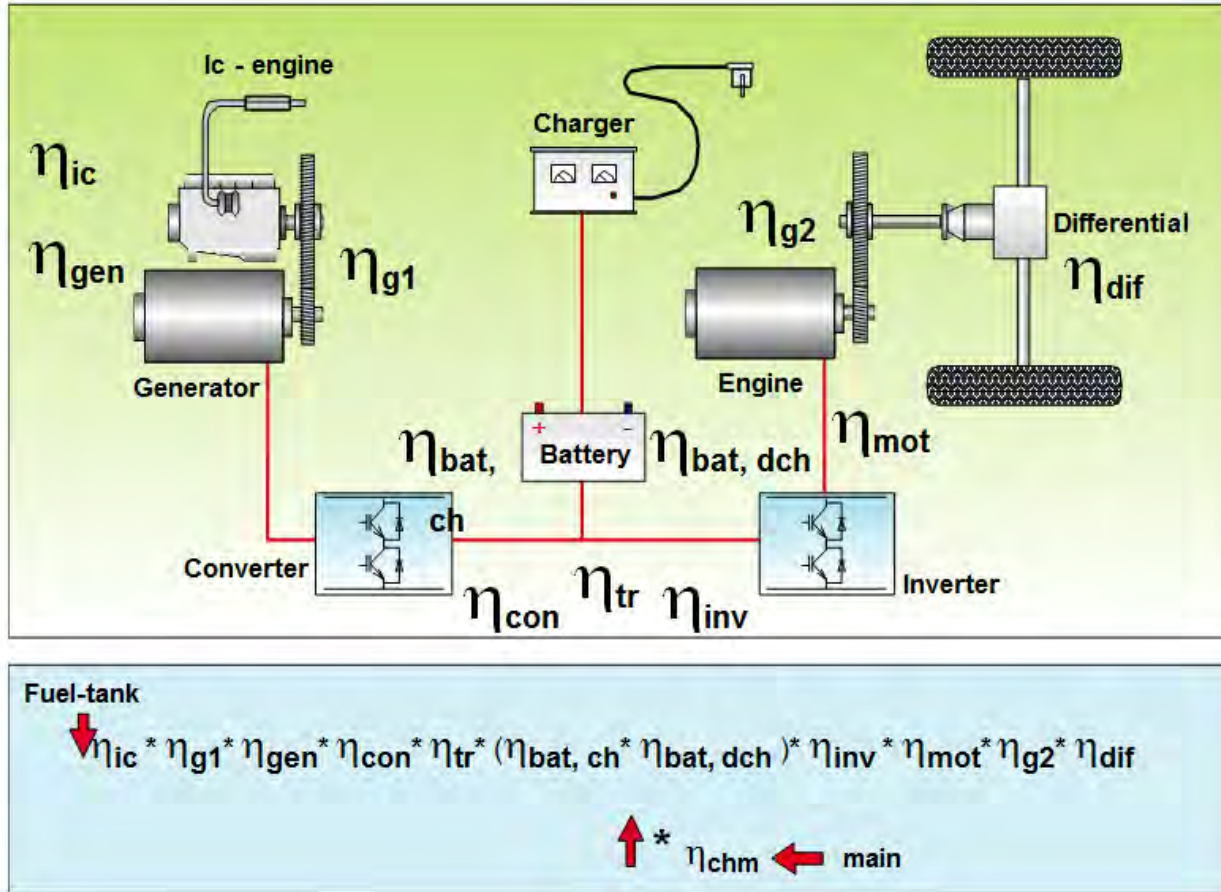

Series hybrid is good for emissions, but a long efficiency chain cannot be good for energy consumption – even with „best operating point“ ice strategy; expensive at high power!!

Range Extender - Magna Mila EV

Mila EV = „electric dominant“ PHEV
(Plug-In Hybrid Electric Vehicle)

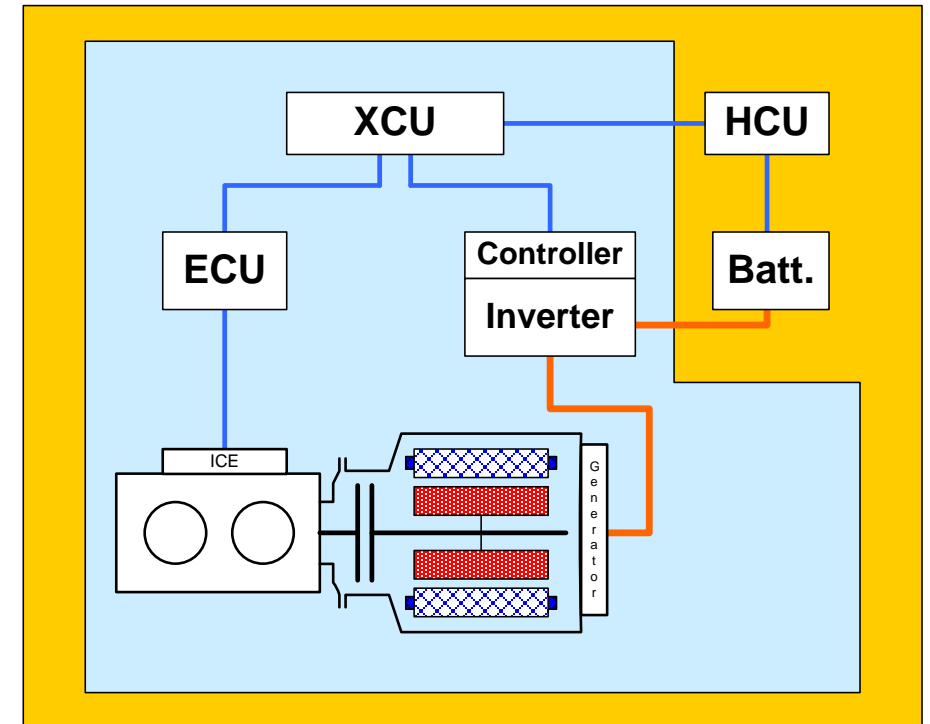
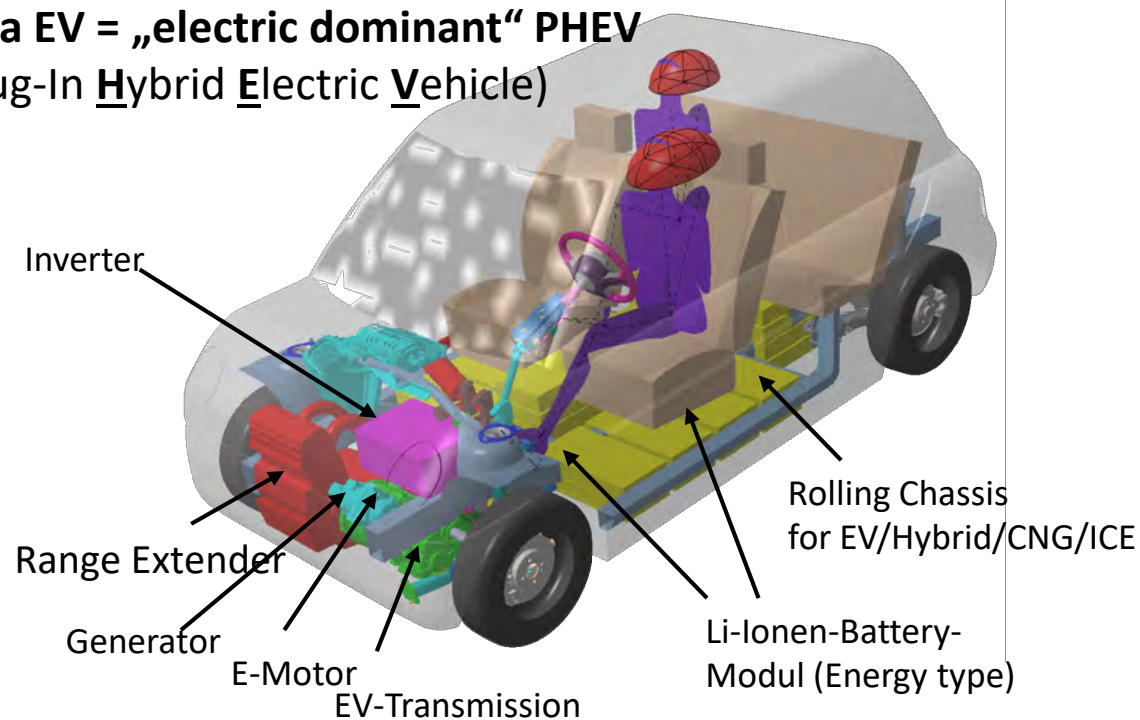

Source: MagnaSteyr

REEV & PHEV Definition

- On-board charging- & energy supply system for (Hybrid-) EVs
- Compact unit consisting of a smaller ice, an electric generator/(motor) and sub systems (fuel supply, exhaust system, vehicle controller)

Application of REX in dominantly electric driven vehicles > 3 possibilities:

- Charging Unit for electric driven vehicles in series arrangement
- additionally with a mechanical coupling to the wheels in parallel, also >> PHEV
- a flexible **combination** of both possibilities (switchable by clutch)

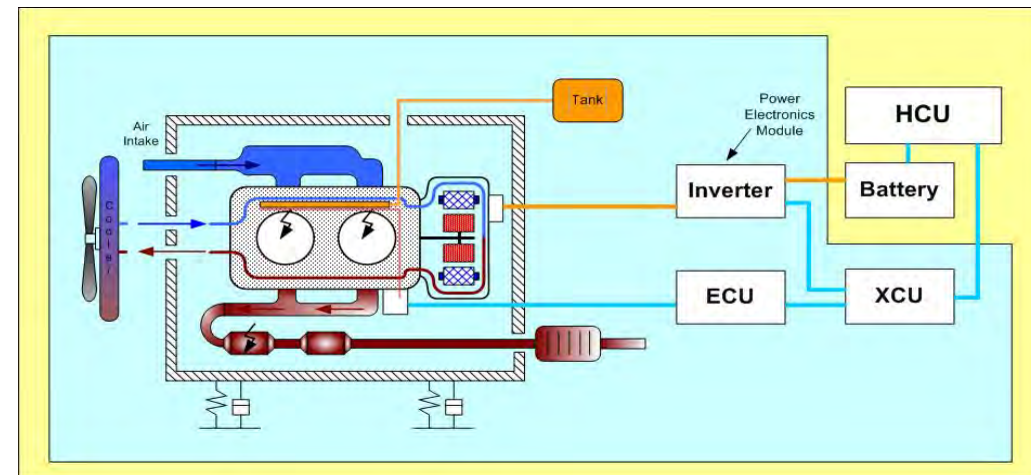

REX Integration

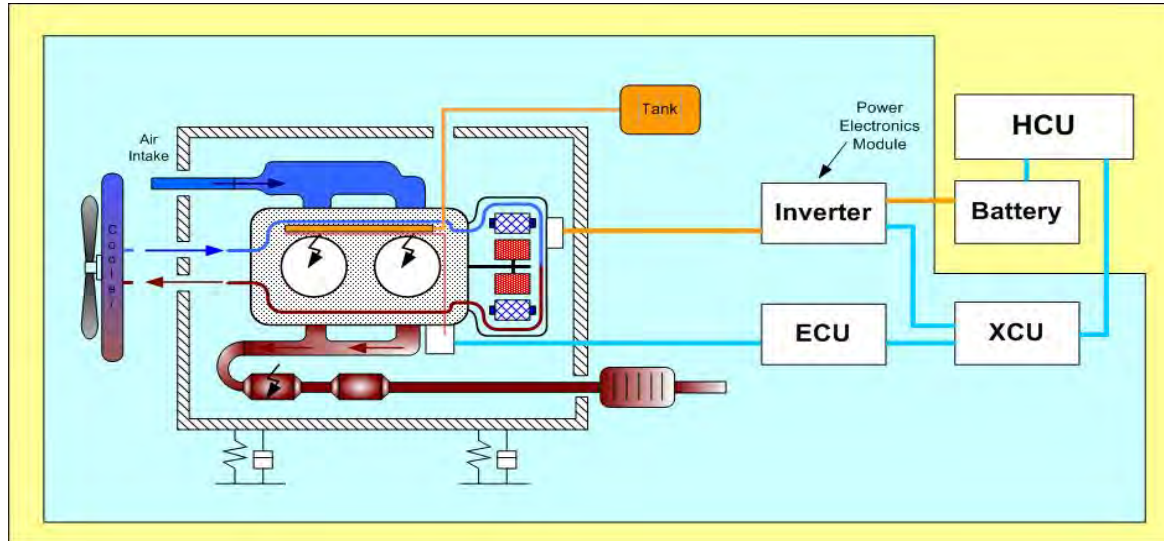

- mechanically sound mounting with extra frame, damper/spring
- Air intake system with filter etc.
- Acoustic capsulation (very important!!)
- Exhaust aftertreatment and exhaust pipe/muffler integration
- High voltage cables, link to battery and inverter
- Link of ECU, xCU (gateway) to hybrid controller

Conclusion of REEV (REX) power discussion



- “small” Range Extender – power is only sufficient to enlarge ranges in urban driving scenarios
- With highway scenarios a too small REX will – sooner or later – lead to a inferior vehicle performance or to standstill with exhausted battery
- A too small REX which cannot increase the battery state of charge considerably when driving at highways, prevents the successful re-entry into environmental sensitive sones or inner cities by pure electric power
- REEV / REX power for a passenger should be at least 30 kW or bigger, that in case of a flat battery, the return to a base/home is possible with acceptable performance
- With increased REX power, REEV and PEHV come more closer to each other! To switch over to a parallel hybrid systems is recommended!



Examples for „after sales“ series hybrides



Other „Range Extender“-Solutions



Co-funded by the
Erasmus+ Programme
of the European Union

Series hybrid - Summary



Advantages of series hybrid

- Delayed start of the gen-set allowing engine and catalyst preheating
 - > emission optimized start strategy
- Engine operation in best operating point (bsfc &/or emission)
- Stationary operation with avoidance of dynamic emission peaks
- Specific shut-down strategy
- Strategies for intermittent operation (i.e. dependent on catalyst cool down)
 - >>> highest potential for emission reduction

Disadvantages of series hybrid

- Too many energy conversions including up to 11 losses >> fuel consumption disadvantage!
- Effort (No. of machines, inverters)



Hybrid vehicle architecture

– Parallel hybrids

Key characteristics:

- Direct, mechanical connection between ICE, electric motor and final drive
- ICE and electric motor(s) can provide traction torque at the same time („parallel“)
- Different variants, depending on arrangement of EM to other components

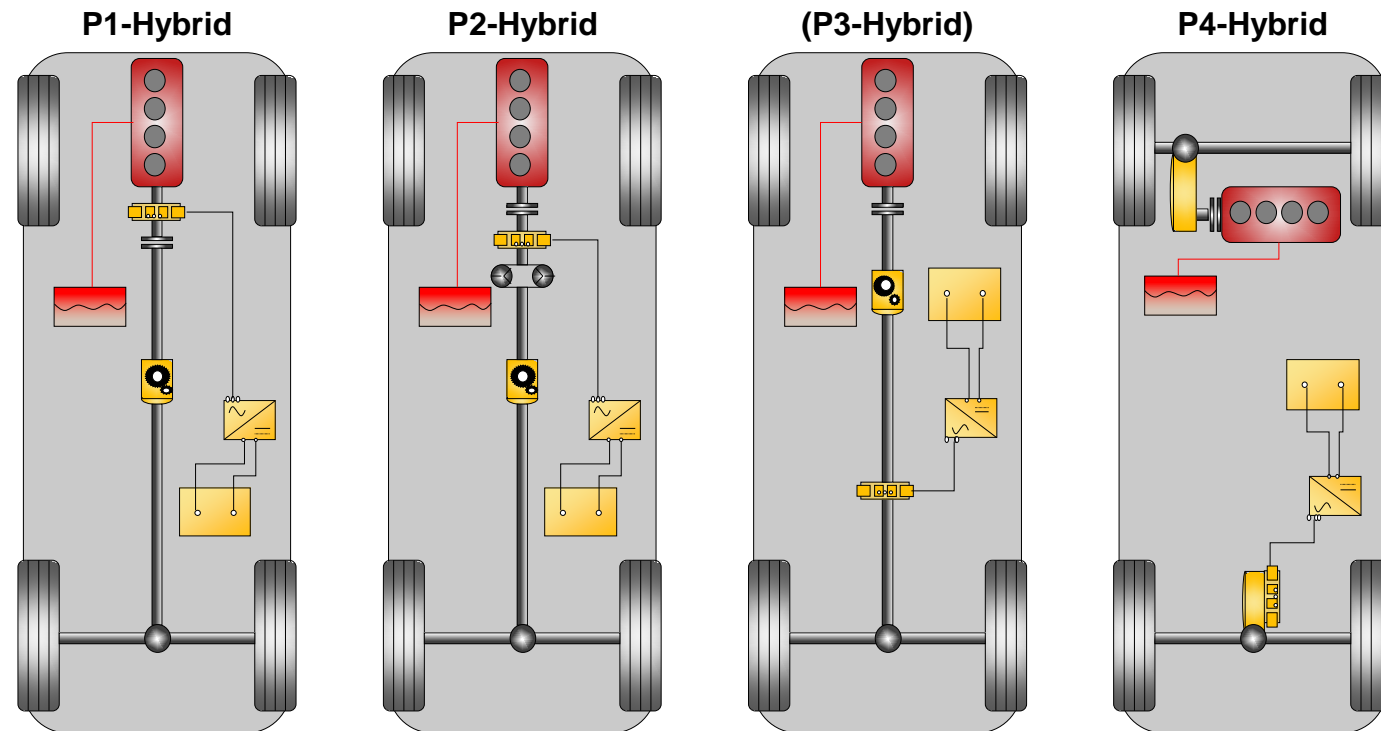

Parallel Hybrid

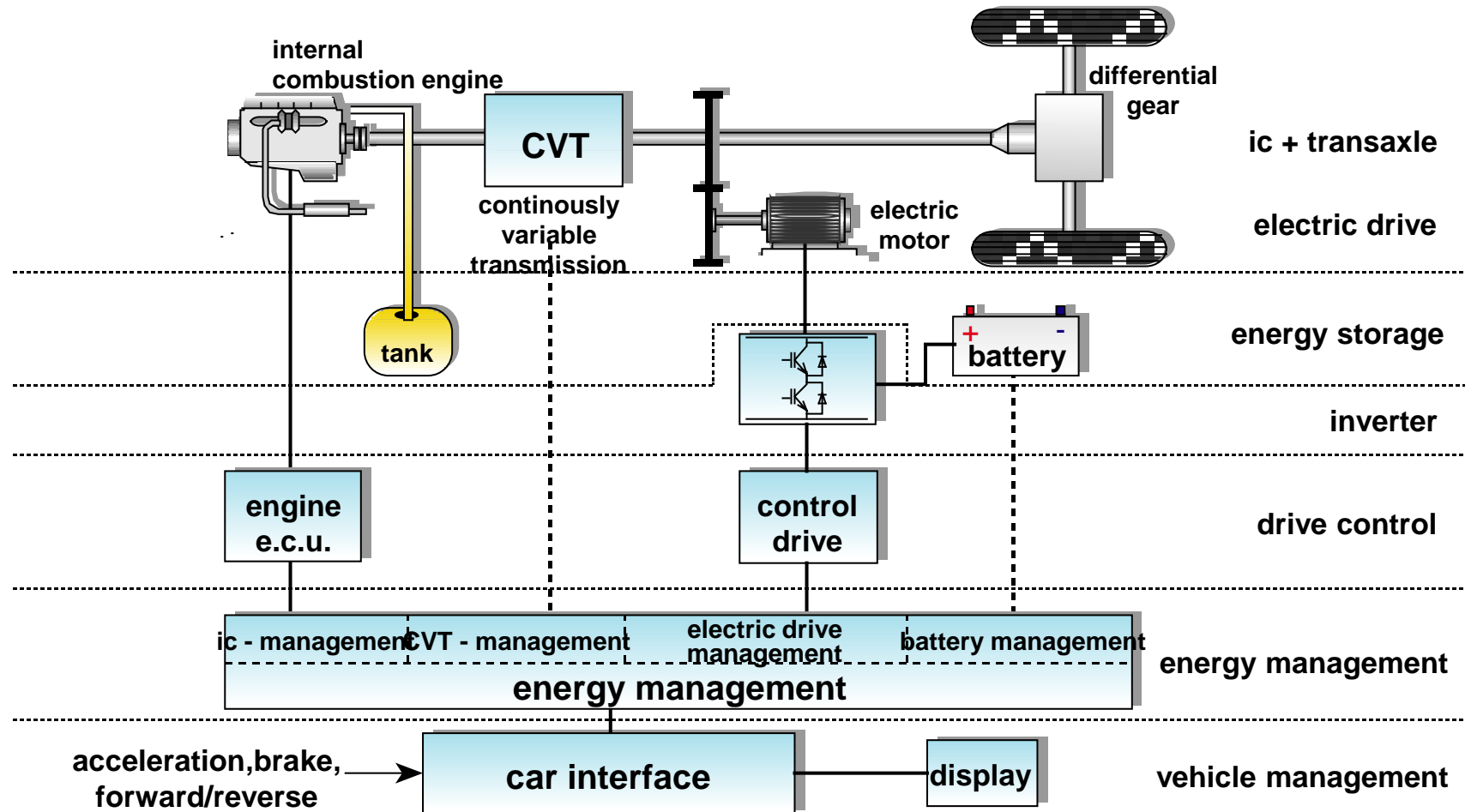

Integrierter Starter-Alternator „ISA“

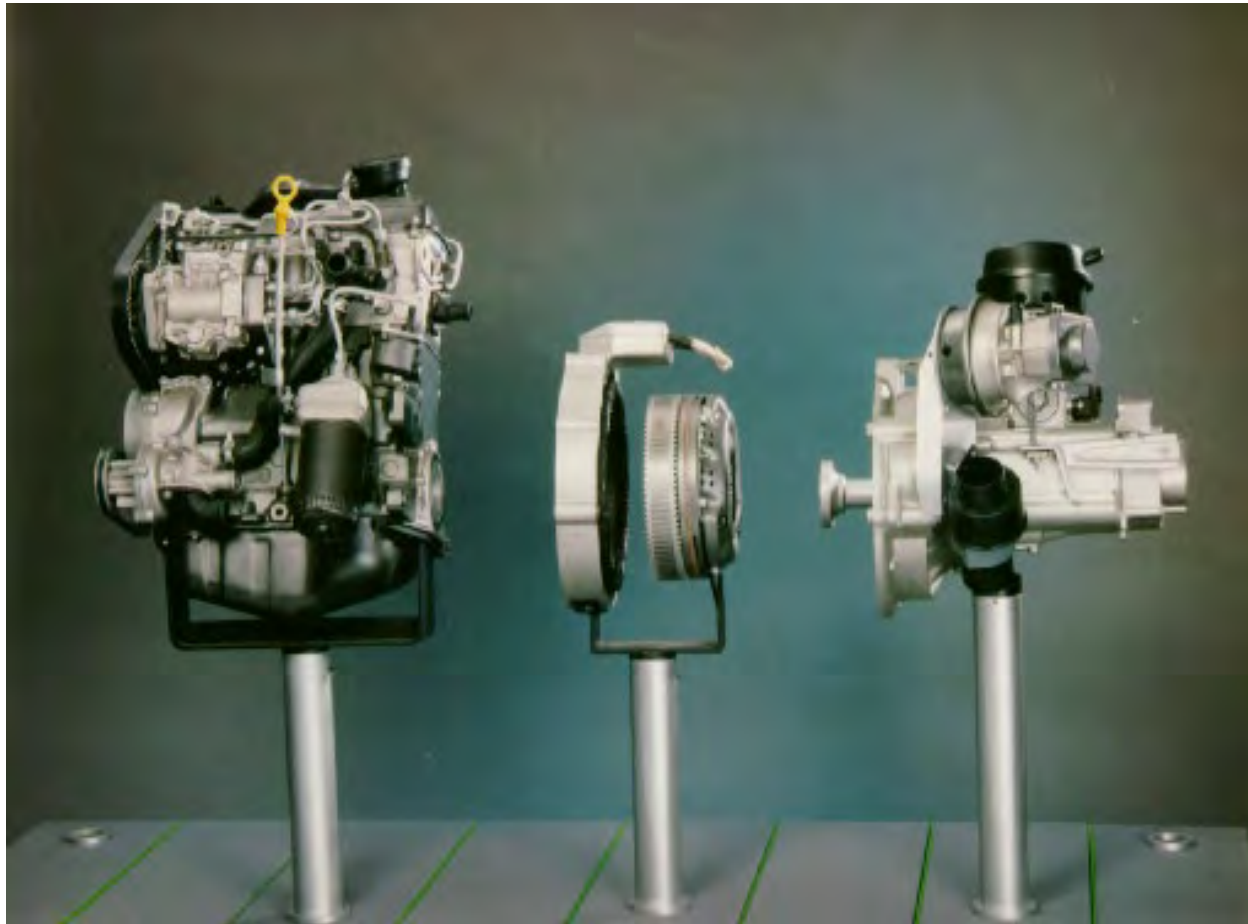

- First „P1“ Hybrid
- VW Golf Hybrid, 1992
- Parallel Hybrid (mild)
- „Add-On“ - solution



Co-funded by the
Erasmus+ Programme
of the European Union

ISA –Components (P1)

E-motor of a crankshaft integrated motor/generator

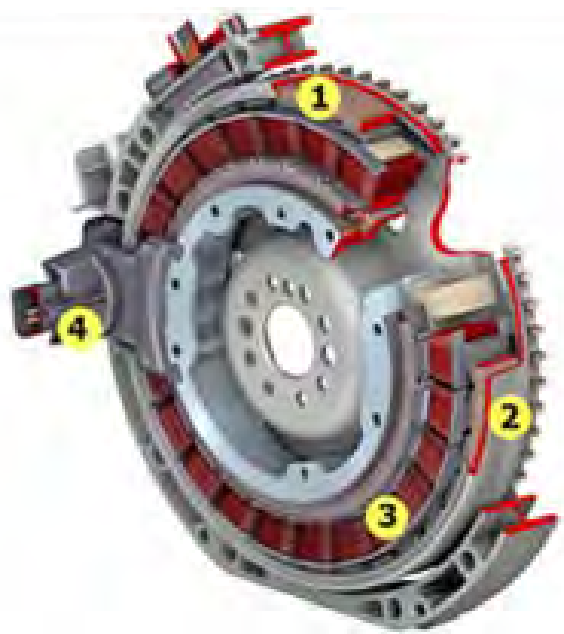

Inverter



Advantages of the ISA application

Following advantages can be achieved:

- Replacement of the in-efficient alternator and replacement of the loud and heavy starter motor
- Sufficient energy supply in the board net
- Very smooth, short and almost silent start of the ice
- Higher starting rpm (better start up)
- At least one belt level less requires (cis) > shorter engine
- Better realization of „Stop & Go“ – operation (easier and less noisy)
- Damping of oscillations in power train
- Lower idle speed (lower fuel consumption!)
- „Boost“-function at phases with high power demand (overtaking)
- Recuperation of break energy to recharge batteries and/or super-caps
- Possibility to reduce cyclic irregularities of the ice especially for ices with 2 or 2 cylinders
- Increased comfort with cylinder deactivation
- Possibility to use even a small e-motor during congestions (pure electric drive).
- Introduction of a second clutch which can disengage the ice



Toyota Micro Hybrid System “P1”

Belt-Integrated ISA



Toyota Crown

THS-M (TOYOTA Mild Hybrid System)

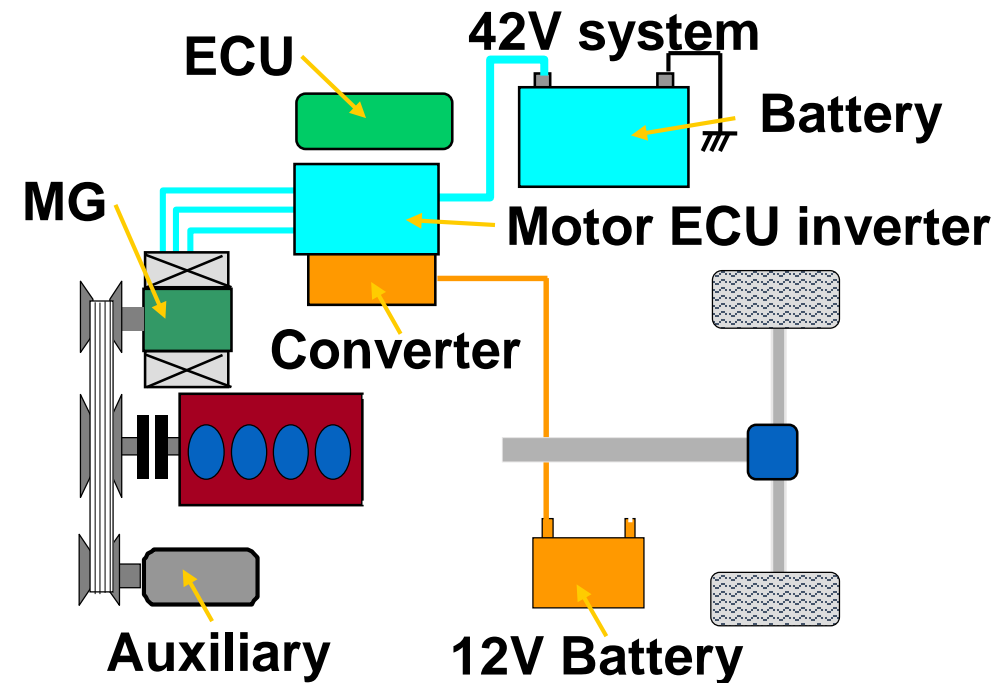

System Characteristics

1. HV system with regenerative braking using simple mechanism
2. Next-generation power source (42V system) as the power system
3. Air conditioner operable during idling stop



VW Touareg Hybrid „P2“

Hybrid Powertrain



- 2 clutches
- E-Motor in the automatic transmission, replacing torque converter

Touareg Hybrid



P2-Hybrid, 279 kW system power
3.0L V6 TSI, 35 kW electric motor
8.2 L/100 km, 0-100 km/h: 6.5 s

Parallel hybrid – first “P4”

Audi Duo
(no drive line connection of front – rear axle)
„through the road“ hybrid

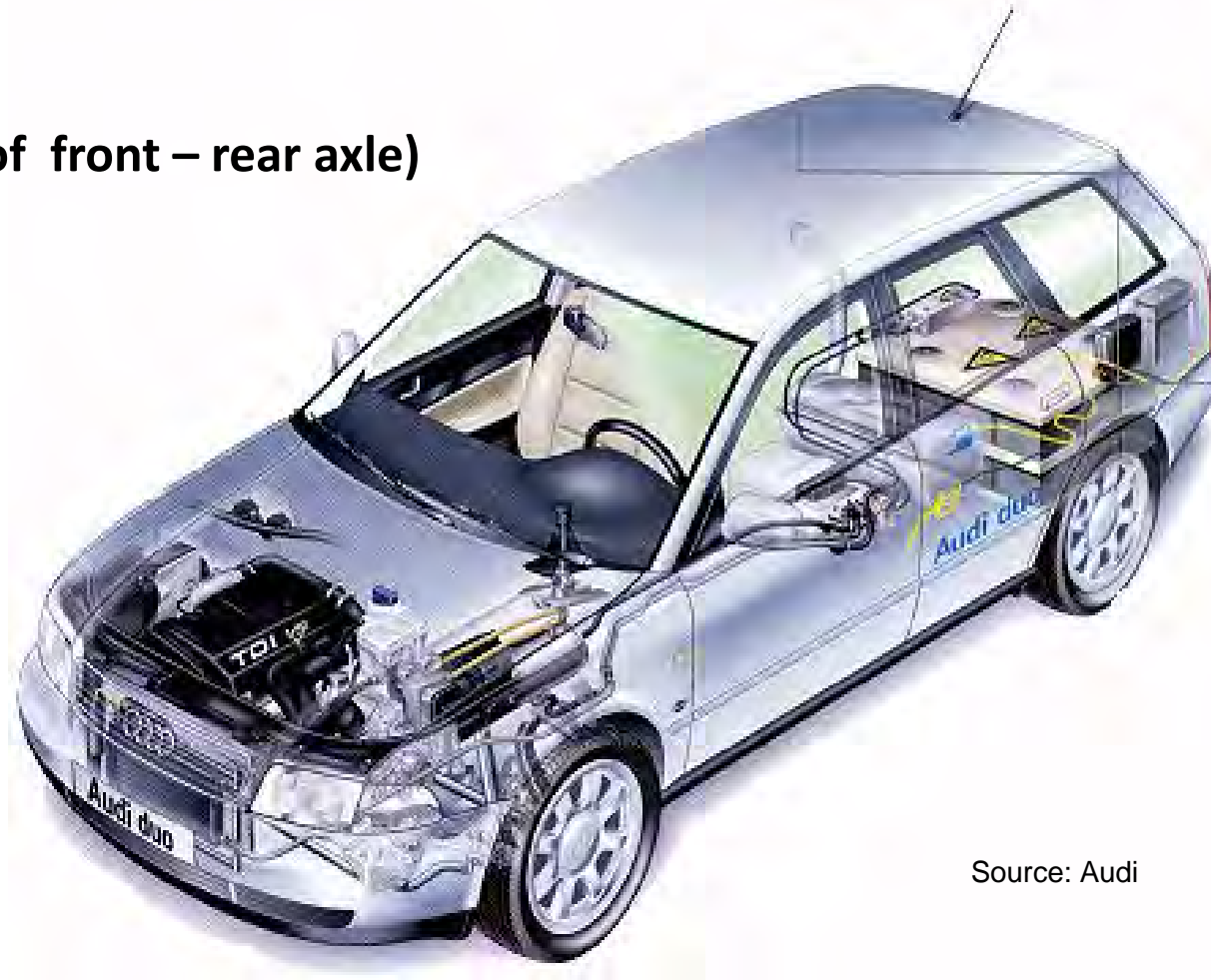

Source: Audi



Co-funded by the
Erasmus+ Programme
of the European Union

Parallel hybrid - Summary



- Direct, mechanical drive from ice to wheels (good efficiency)
- One- and two shaft solutions
- Reduced dynamics @ the ice possible when a CVT is used

Advantages of the parallel hybrids

- Only one electric machine necessary
- Dimensioning of the powertrain components (ice > Vmax; E-Motor > city)
- >>> highest potential for low fuel consumption

Disadvantages of parallel hybrids

- Ice not stationary any more and not independent from wheel
- In case of a combination with CVT, CVTs have also not so excellent efficiencies



Hybrid vehicle architectures – Power Split

Key Properties:

- Power split device = planetary gear set
- Shaft power is split into 2 paths: mechanical & electrical
- **Input Power Split:**
 - ICE power → Traction- and charging power



- **Output Power Split:**
 - ICE and EM power → Traction- and charging power

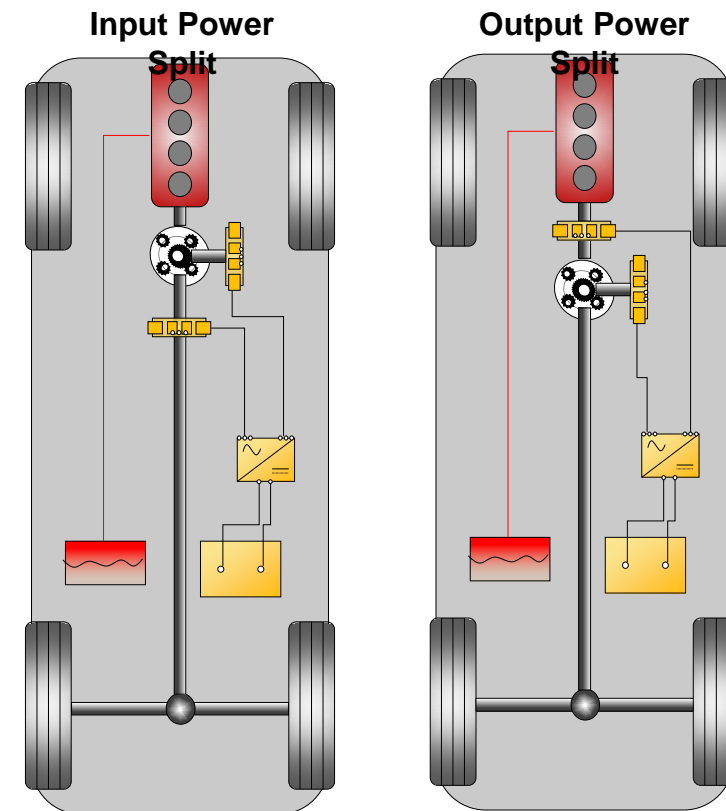
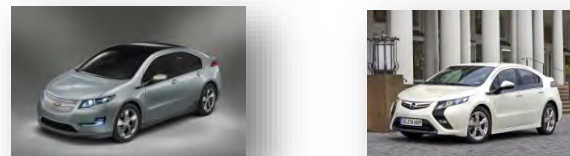

Power Split Hybrid

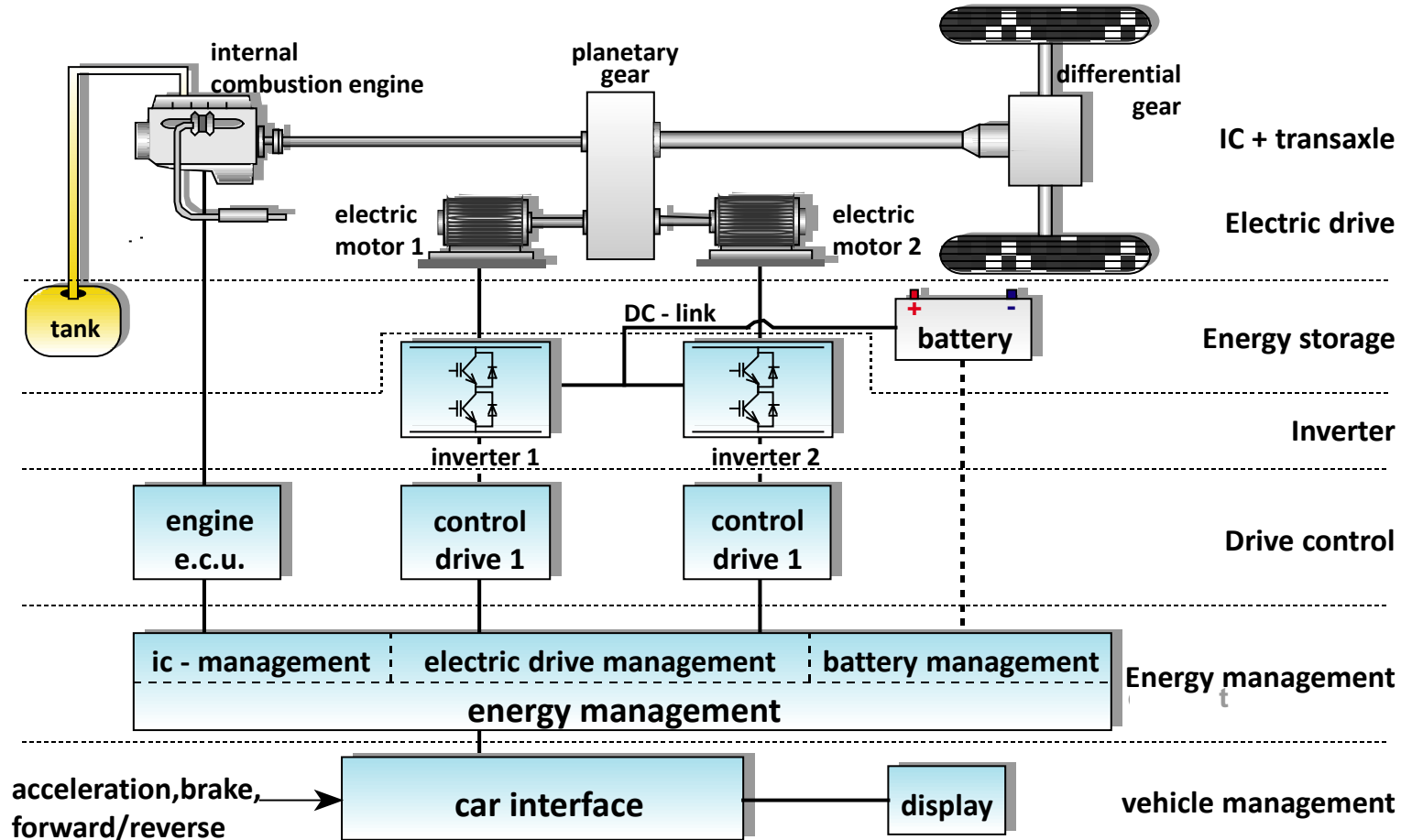

UHS Hybrid – Powertrain (AVL)

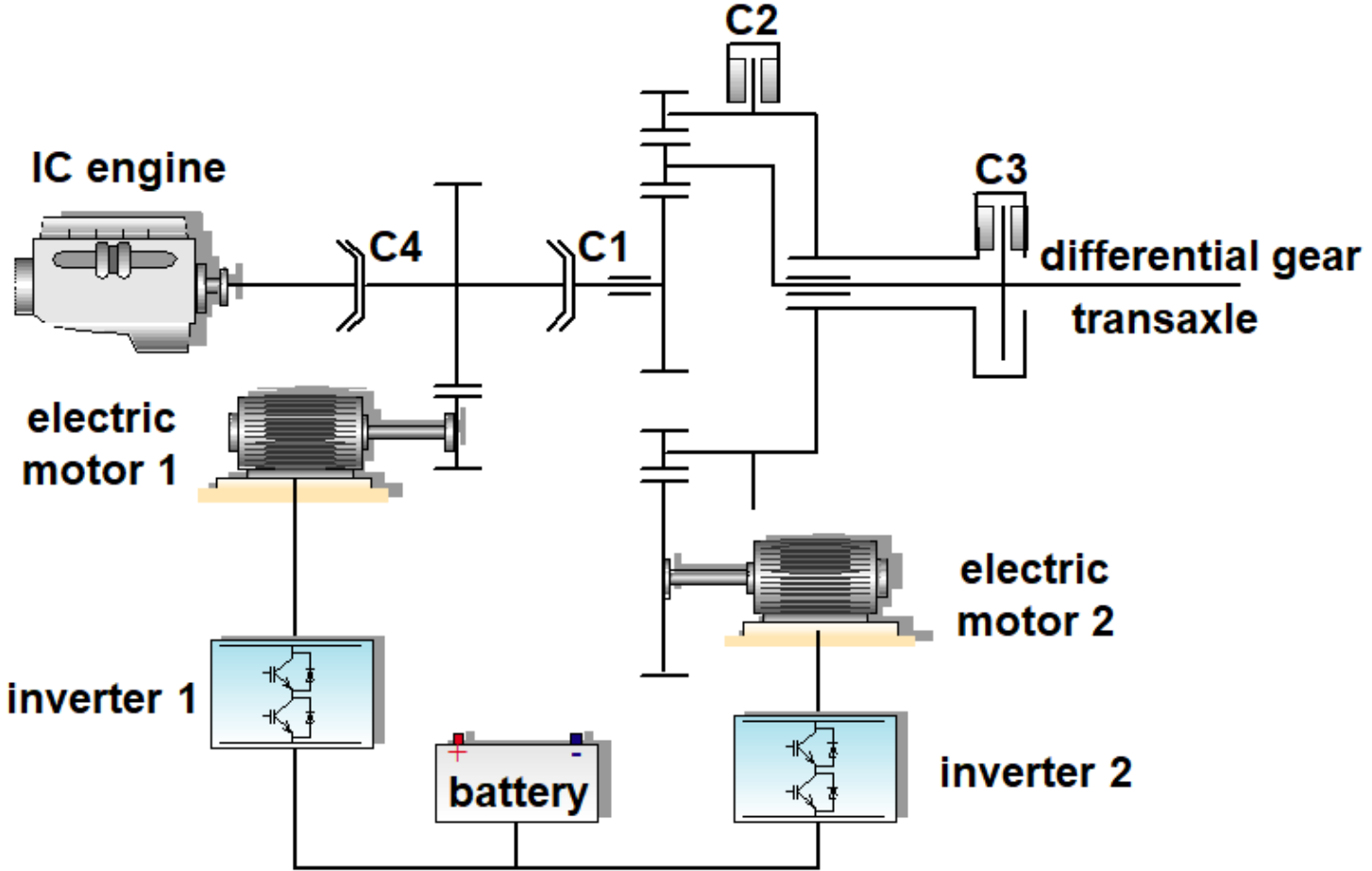

UHS / THS Hybrid – Drive Power flow in CVT Mode

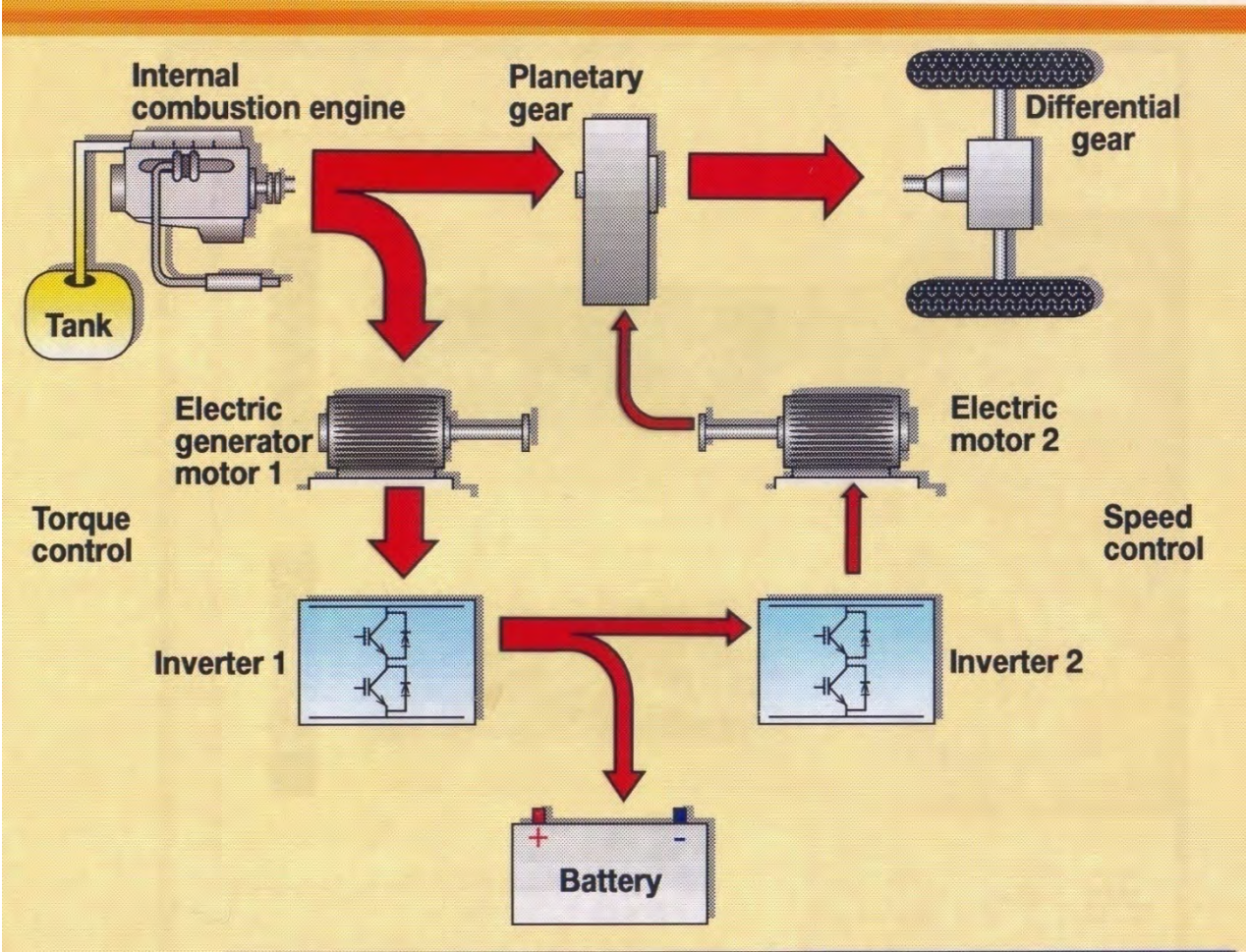

Co-funded by the
Erasmus+ Programme
of the European Union

Power split hybrids



Mixed hybrid drive trains („electro-mechan. transmissions)

Hybrid-structure selectable > operation as series as well as parallel hybrid possible

Example: AVL Universal-Hybrid System (UHS)

- Energy flow distributor = Planetary gear
- Electro motor (EM1) is controlling the output torque
- Electro motor (EM2) is controlling the output speed

Advantages and disadvantages of mixed hybrids:

- Combines advantages & disadvantages of series- & parallel hybrids
- Effort (machines, controller)
- Danger of idle power



Toyota Prius – a power split hybrid



First mass produced
hybrid vehicle 1996
Power split hybrid
(using planetary gear)



Co-funded by the
Erasmus+ Programme
of the European Union

FOR EDUCATIONAL PURPOSE ONLY

Toyota Prius THS System

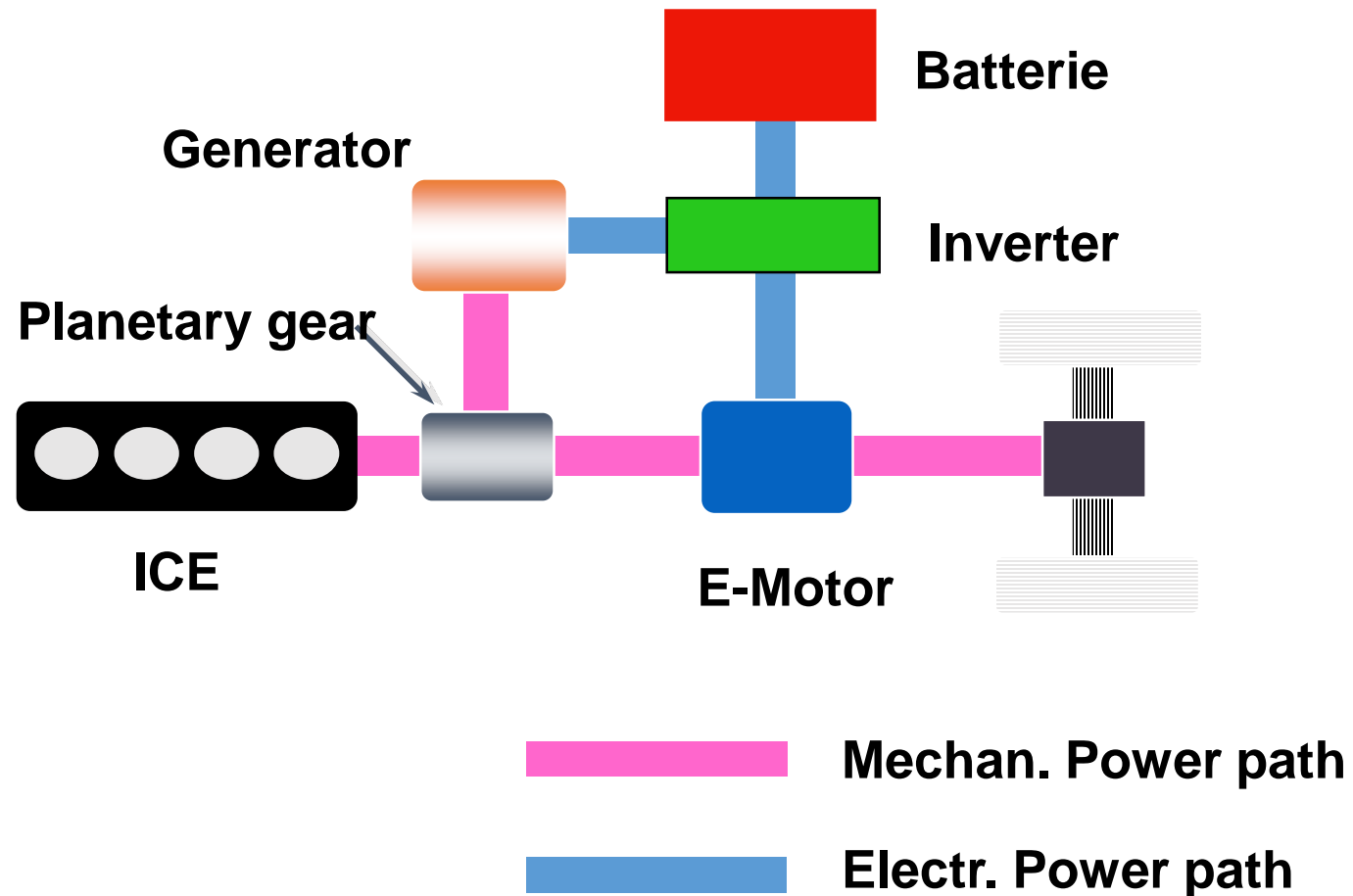

General design of a power split transmission with 2 electric motors

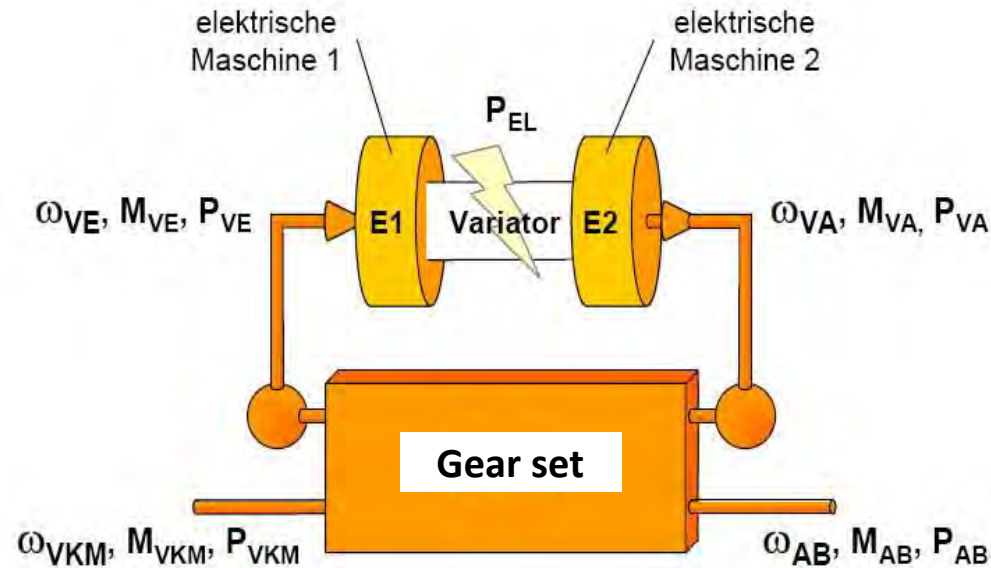

Power flow

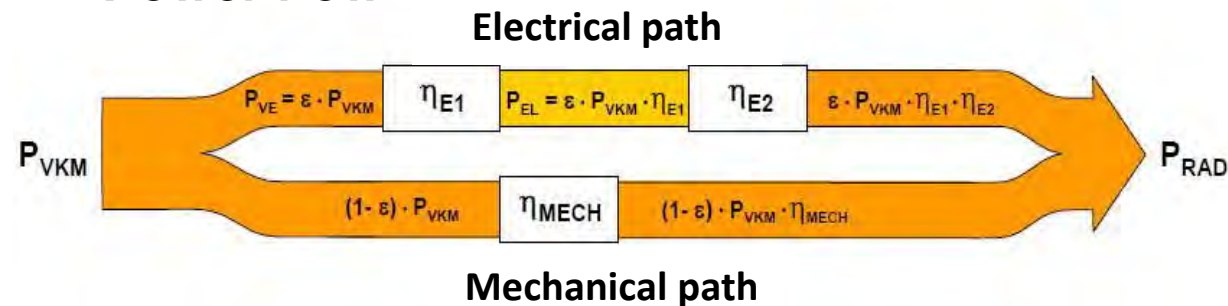

Disadvantage with planetary gears: Idle power flow with Prius powertrain

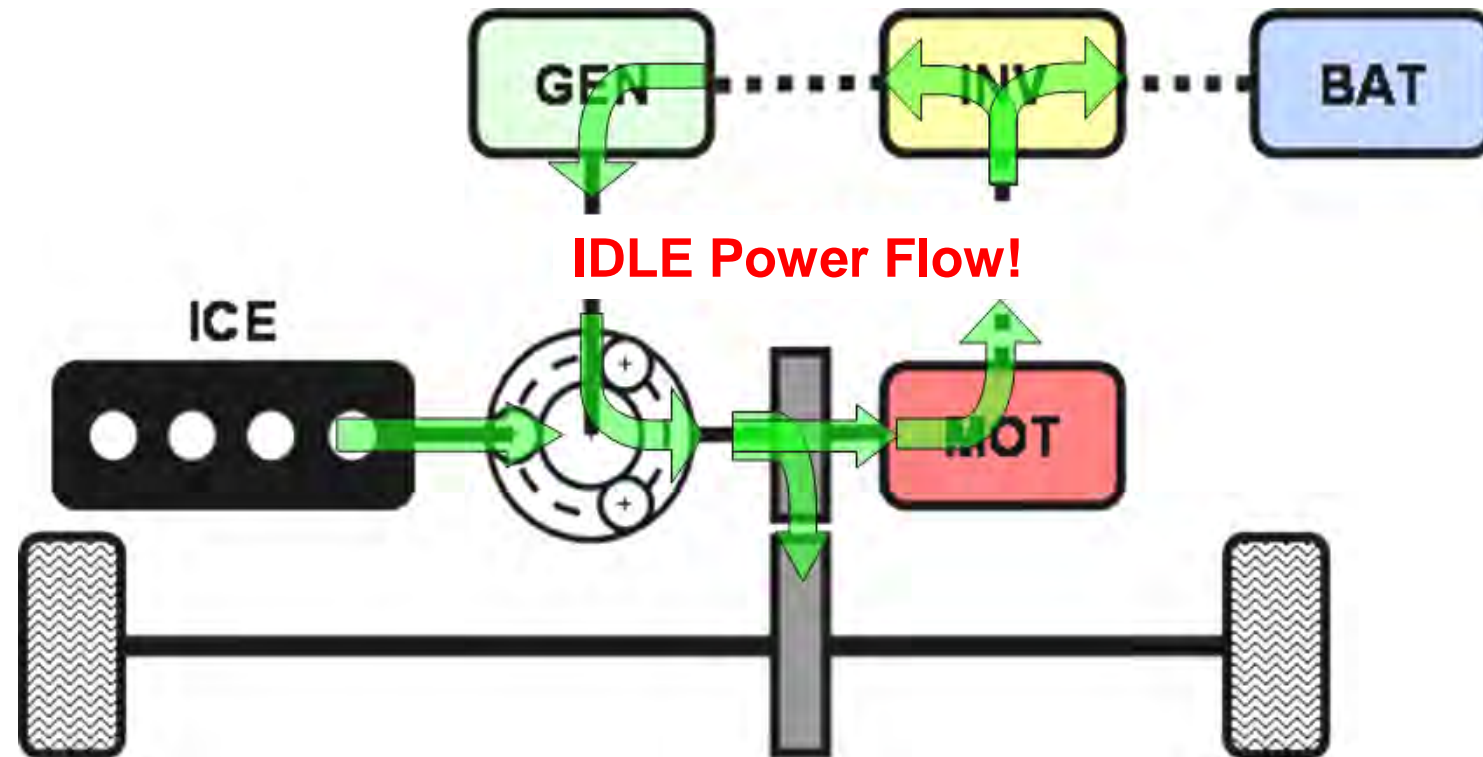

THS I System in natura

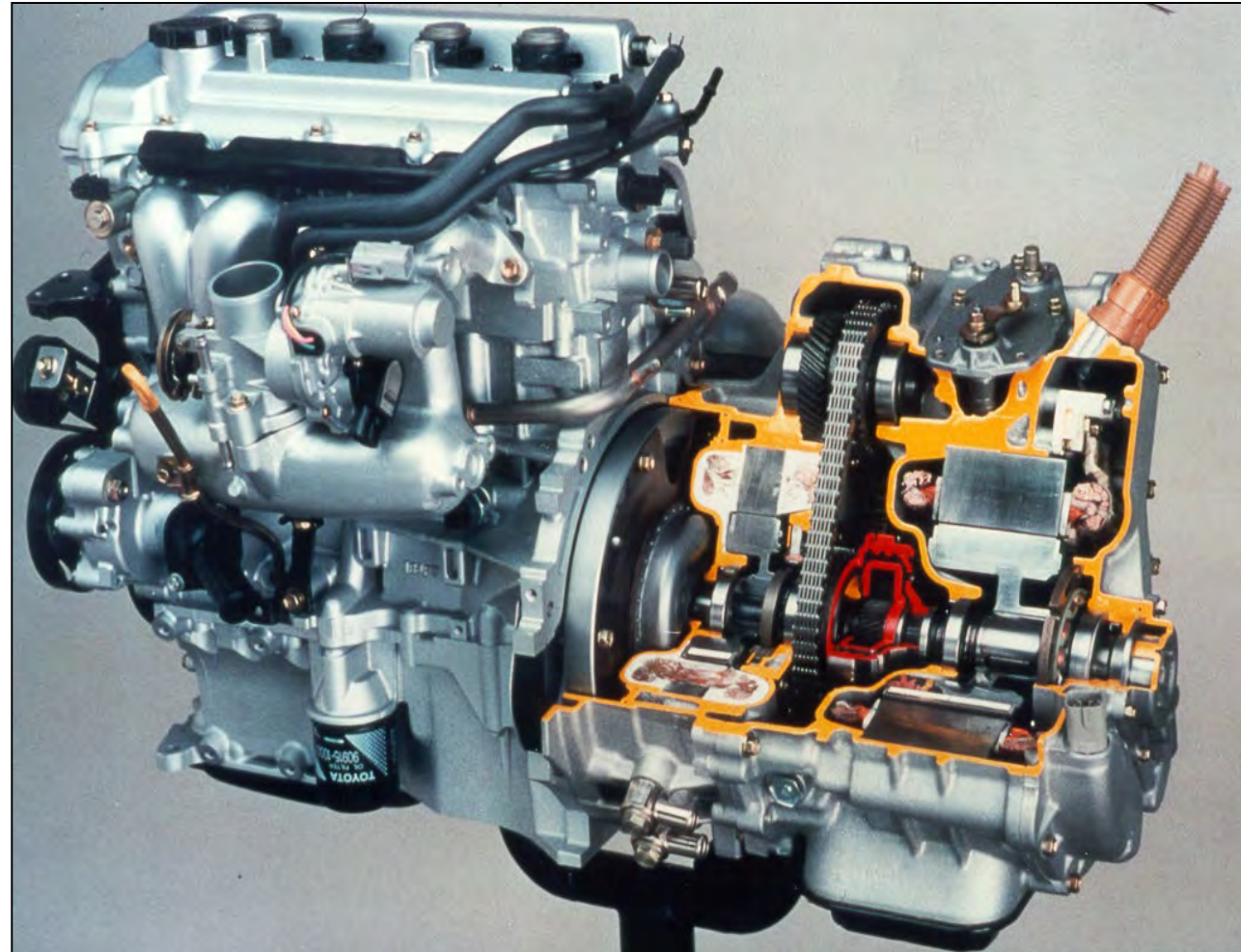

Co-funded by the
Erasmus+ Programme
of the European Union

FOR EDUCATIONAL PURPOSE ONLY

Further development – Two-Mode-Hybrid

Key Characteristics:

- 2 electric motors, 3 planetary sets; 2 clutches (C2, C3), 2 brakes (C1, C4)
- 2-Mode: either input power split or multiple power split

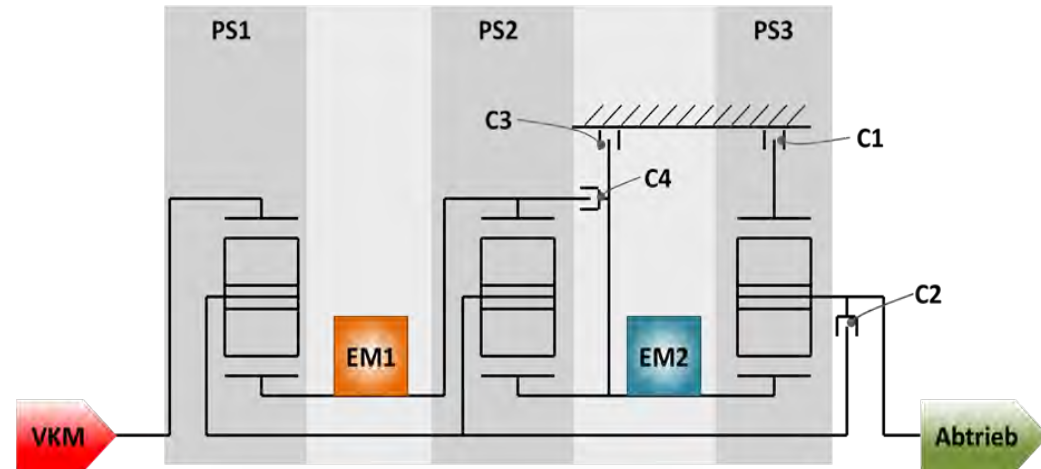
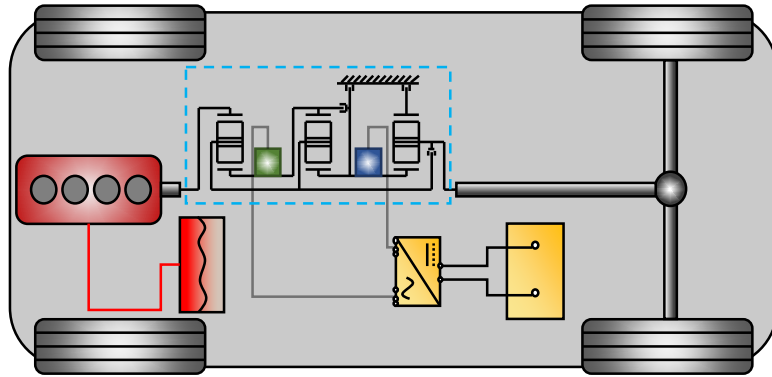

AHS-C Transmission in BMW X6

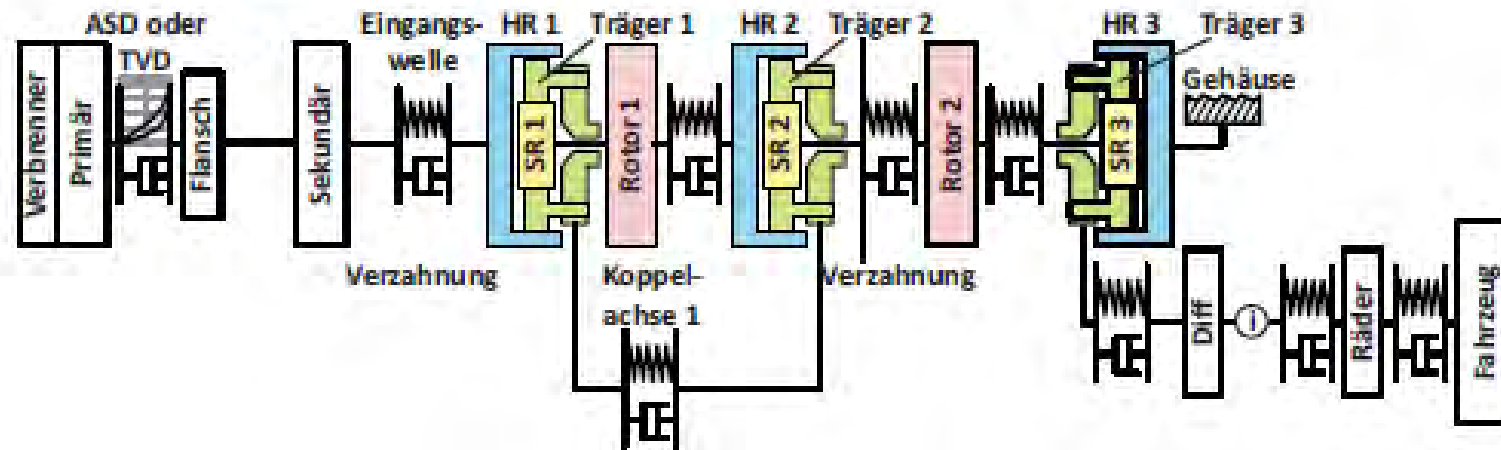

ICEs in hybrid concepts



Problem for dimensioning:

Big power spread:

- City traffic (4-8 kW);
- Highway, high power demand (60-120 kW)

A) Conventional piston engines

- Diesel engine
- Gasoline engine
- Engines with alternative fuels

B) Special ice with internal combustion

- Free piston engines
- Rotary piston engines (Wankel,..)

C) ICEs with external combustion

- Gasturbines
- Stirling engines
- Steam engines



Co-funded by the
Erasmus+ Programme
of the European Union

ICEs in hybrid concepts – Resumé



Gasoline engine

- Most favorable variant, especially for series hybrid applications
- With small displacements the fuel consumption difference compared to Diesel engines is low
- Fulfills stringent emission requirements (i.e. ULEV) with Lambda=1-concept
- Catalyst conversion rates over 98%, with hydro carbons 99%
- Advantages: NVH, smaller production costs and higher customer acceptance
- Availability in the small displacement classes (motorcycles etc)

Diesel engine

- TDI with intercooling promises best fuel consumption >> best CO₂ –reduction
- Relatively low engine out emissions, but still NOx problem
- Disadvantages: relatively heavy and loud, big effort in the emissions needed (particulate matter emission), NVH, acceptance problem
- ULEV Standard with today's technologies hard to achieve



ICEs in hybrid concepts – Resumé



Gas turbines and Stirling engines:

- Good in stationary applications (i.e. range extender), worse in dynamic applications
- Multi-fuel capability
- Lowest raw emissions achievable, especially very low NO_x-emissions
- Gas turbines are flow machines and need high mass flow (not suitable for small power outputs or part load conditions!)
- Good efficiency prospects, but
- Efficient gas turbines and Stirling engines need heat exchangers!
- Heat exchangers require too big specific space and have too big weight
- short- to midterm no good prospects for applications in hybrids



Hybrid powertrain – main operating modes



Following typical hybrid need to be realized by the hybrid control system:

- **Start / Stop Strategy**: engine shut-off of when vehicle is stalled and immediate ice start when touching throttle pedal
- **Recuperation**: recovery of braking energy by generator mode of the e-motor, charging of tractions battery while motoring the vehicle
- **„Boosten“**: short time adding of electric motor and ice torque for acceleration
- **Load shifting of ic-engine** : charging battery during driving by ic-engine (higher torque demand than required for driving, using better efficiency areas of engine map)
- **Charging of battery in vehicle standstill**: generator-mode



Hybrid powertrain – main operating modes



Following typical hybrid need to be realized by the hybrid control system:

- **Start / Stop Strategy**: engine shut-off of when vehicle is stalled and immediate ice start when touching throttle pedal
- **Recuperation**: recovery of braking energy by generator mode of the e-motor, charging of tractions battery while motoring the vehicle
- **“Boosten”**: short time adding of electric motor and ice torque for acceleration
- **Load shifting of ic-engine** : charging battery during driving by ic-engine (higher torque demand than required for driving, using better efficiency areas of engine map)
- **Charging of battery in vehicle standstill**: generator-mode

TOPIC OF ENERGY MANAGEMENT



Hybrids – an Alternative?!



A few questions:

- **Give me an instant feedback on the content!**
- **What is your teaching attitude regarding hybrids?** Are people thinking the “pure solution” (BEV) or conventional PT is better and hybrid are just an intermediate solution?
- **Do think the hybrid application can prolong the life of the ice** (remember Thomas’s presentation with the ban of ice in 5 to 20 years?). Is a combination with alternative fuels reasonable?
- **How can we make students interested in hybrids?**
 - Do you have engine labs/infrastructure that you can also test the combination of ice and electric motors in your labs?
 - Can you do ice/e-motor simulations and experiments ?
- **Learning targets for students in “Hybrids”**
 - Get an Overview about all possible architectures, major component characteristics and application issues
 - Understand the different pros and cons for different hybrid arrangements and fuel consumption/CO₂ possibility
 - Understand technical, societal and environmental impact





Engineering Knowledge Transfer Units to Increase Student's Employability and Regional Development



<https://www.facebook.com/unitederasmus/>



Co-funded by the
Erasmus+ Programme
of the European Union

This project has been funded with support from the European Commission. This publication reflects the views only of the author, and the Commission cannot be held responsible for any use which may be made of the information contained therein.
598710-EPP-1-2018-1-AT-EPPKA2-CBHE-JP

FOR EDUCATIONAL PURPOSE ONLY



Engineering Knowledge Transfer Units to Increase
Student's Employability and Regional Development

Options for a CO₂ reduced Mobility

ICE / Electric Hybrid Vehicles



Co-funded by the
Erasmus+ Programme
of the European Union

This project has been funded with support from the European Commission. This publication reflects the views only of the author, and the Commission cannot be held responsible for any use which may be made of the information contained therein.

598710-EPP-1-2018-1-AT-EPPKA2-CBHE-JP

FOR EDUCATIONAL PURPOSE ONLY

Future diversification of Powertrains

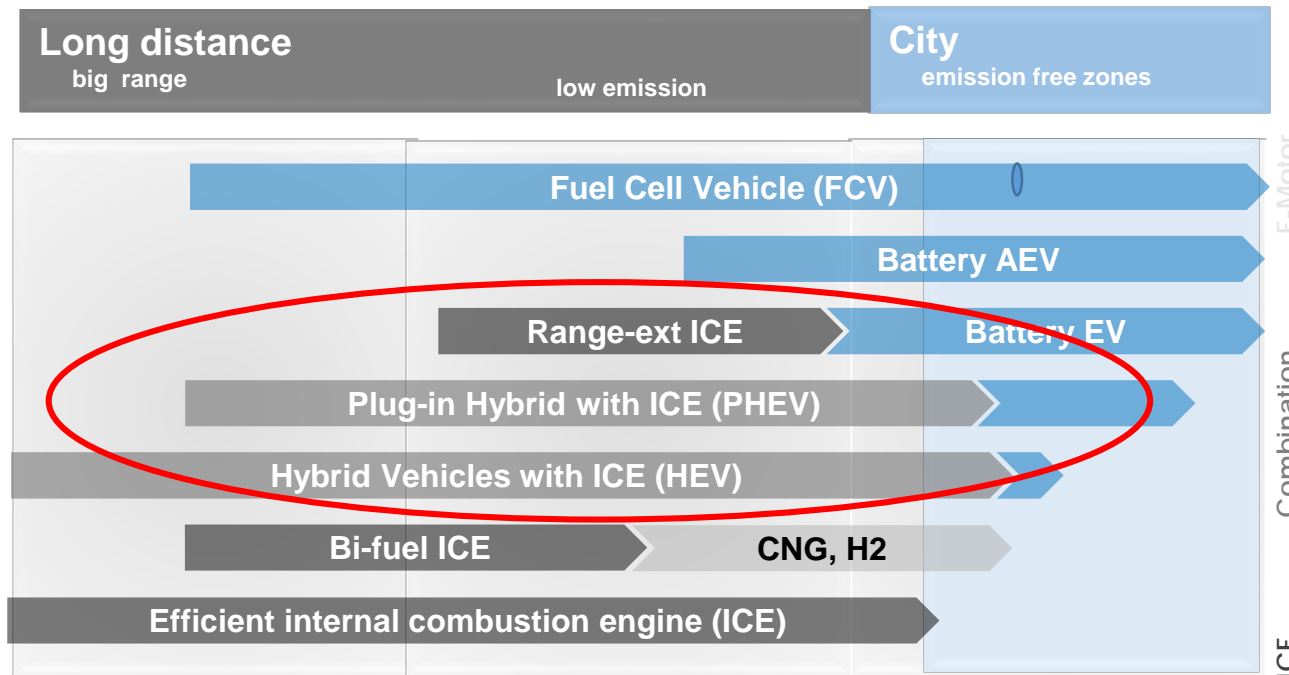

Diversification of powertrains and fuels to fulfil CO₂ legislation

- ### Advanced powertrains
- High Engineering demand
 - New Components & Systems
 - Electrification need battery systems with high energy density
 - CNG and hydrogen need high pressure gaseous storages



■ locally emission free ■ low CO₂, NO_x, etc. ■ CO₂, other emissions (PM, NO_x, HC, CO, O₃)

1st Austrian Hybrids by Lohner / Porsche

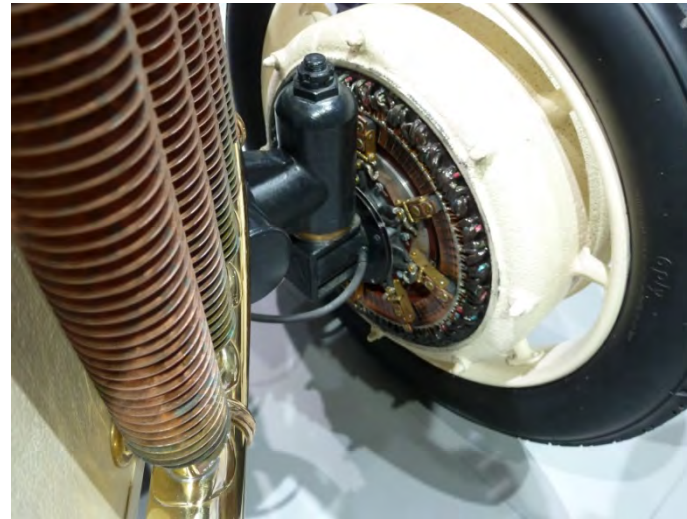

Detail: wheel-hub motor

- Hybrids are nothing new
- Built around 1900

1st Austrian Hybrids by Lohner / Porsche



- First patents 1897
- Around 1900 already small series productions



Co-funded by the
Erasmus+ Programme
of the European Union

FOR EDUCATIONAL PURPOSE ONLY





Toyota Prius



First mass produced hybrid vehicle 1996
Power split hybrid (using planetary gear)

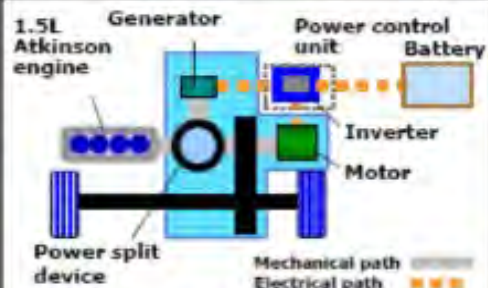
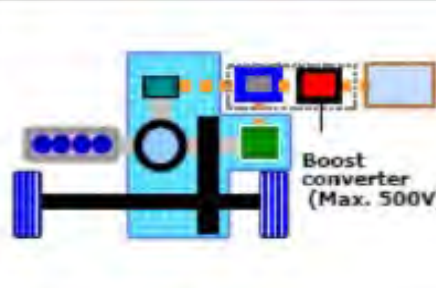
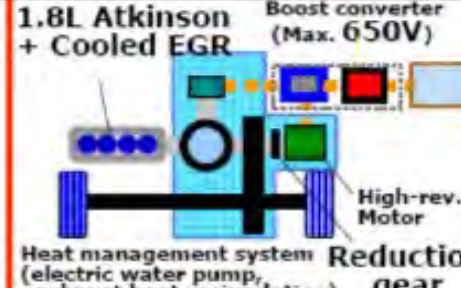

Toyota Prius - Evolution

	1st system (1997)	2nd system (2003)	New system (2009)
Objective	First mass produced HV, Outstanding fuel economy	Improved Performance	Further improved on-road fuel economy
Overall system	 <p>1.5L Atkinson engine, Generator, Power control unit, Battery, Inverter, Motor, Power split device, Mechanical path, Electrical path</p>	 <p>Boost converter (Max. 500V)</p>	 <p>1.8L Atkinson + Cooled EGR, Boost converter (Max. 650V), High-rev. Motor, Heat management system (electric water pump, exhaust heat recirculation), Reduction gear</p>
Engine output	43kW	57kW	73kW
Motor output	33kW	50kW	60kW
Motor max rev.	6,000rpm	6,400rpm	13,500rpm
Vehicle exterior			

Copyright (C) 2010, TOYOTA MOTOR CORP & TOYOTA MOTOR EUROPE. All Rights Reserved.

TOYOTA



Co-funded by the
Erasmus+ Programme
of the European Union

Toyota Prius III



▪ Weight empty:	1.445 kg
▪ ICE 4 Cyl, 1,8 l:	max. power 73 kW,
▪ max. Torque.	142 Nm at 4000 rpm
▪ E-Motor:	60 kW peak
▪ System power ice+E:	100 kW
▪ V max:	180 km/h
▪ Accel. 0–100 km/h:	10.4 sek
▪ Cw:	0,25
▪ frontal aera:	app. 2,4 m ² Cw * A: ca. 0,6 m ²

Current sales numbers worldwide have reached >> 9 million
= highest sales of a hybrid vehicle

Source: Toyota Motors



Toyota Prius III – electrical specs



- **Battery NiMH (supplier Panasonic):**
 - 28 modules a 6 cells – i.e. 168 total cells
 - Voltage per cell of 1.2 V result in 201,6 V
 - Weight: 39 kg
 - Energy content: appr. 1,3 kWh
 - SOC window very small 15 to 20% (target 60%)
 - Step-up converter: voltage of the battery is boosted to app. 500 V for the e-machines (e-machines can then be built smaller and have higher efficiency)
- **Range pure electric: approx. 2-3 km**
- **Vmax pure electrical: 45 km/h**

Next Generation Prius Plug-In

- Battery Li-Ion

Estima (= RX 400 H AWD) Hybrid

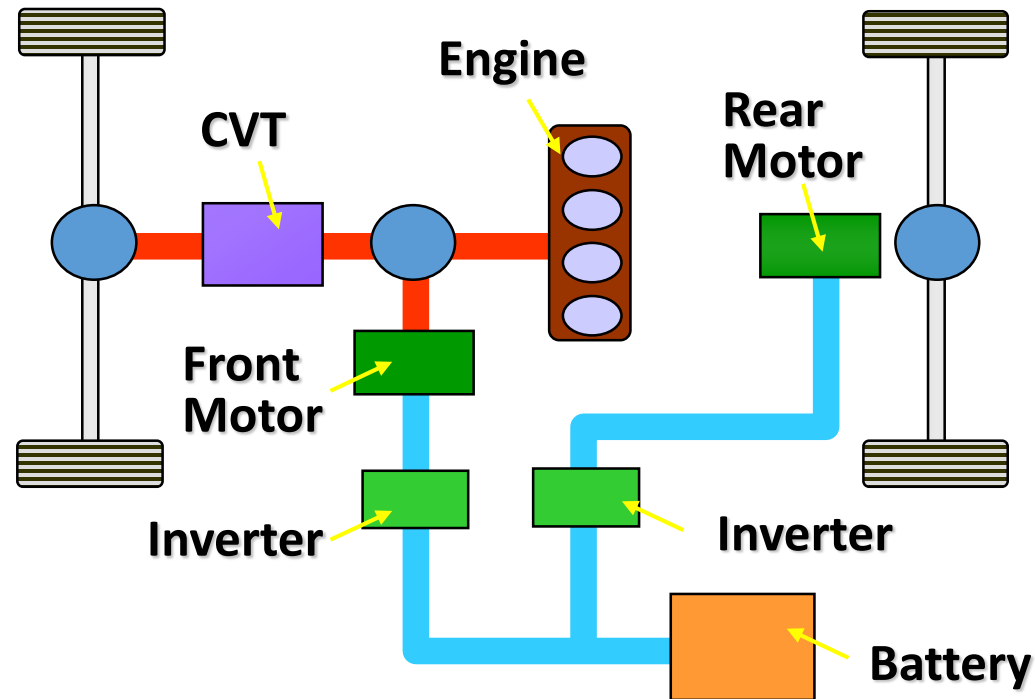

System Characteristics

- 1.HV system incorporating CVT**
- 2.Simple switchover to electronic 4WD by rear motor**



Honda IMA System (Civic)

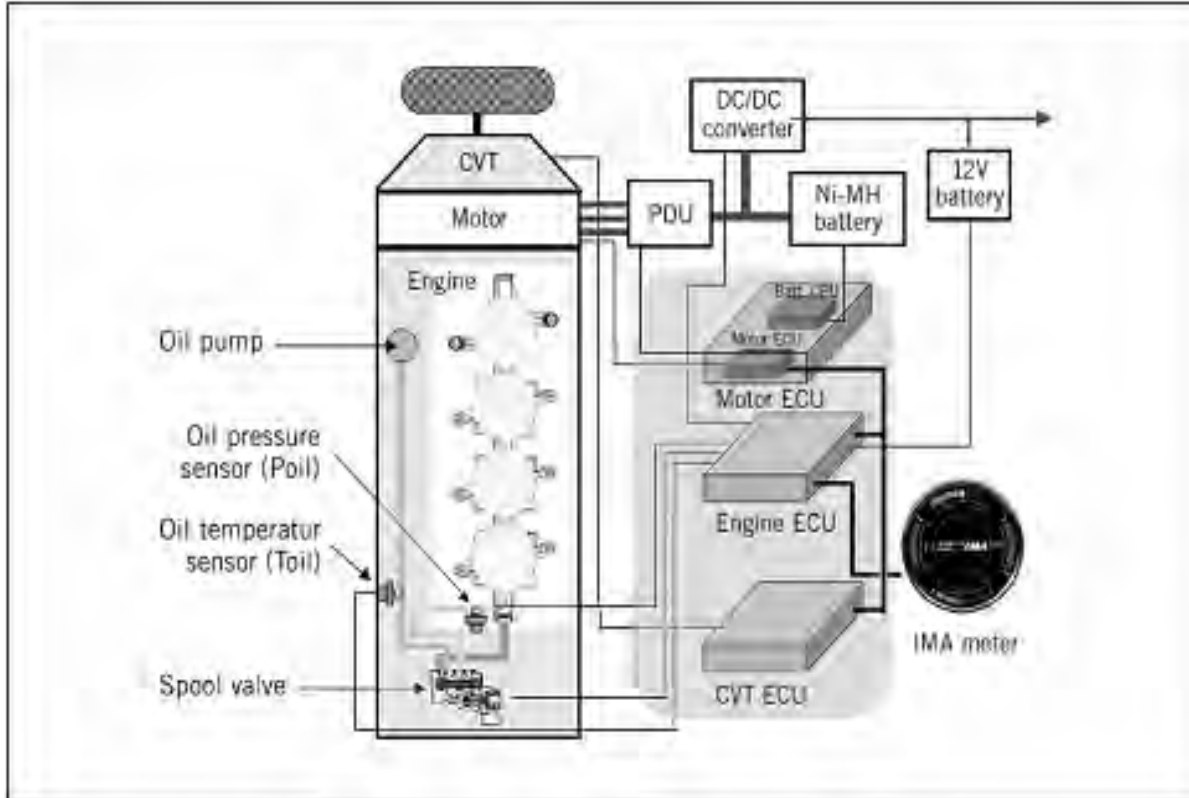

Directed to comfort & emission reduction!



Co-funded by the
Erasmus+ Programme
of the European Union

GM Silverado Hybrid

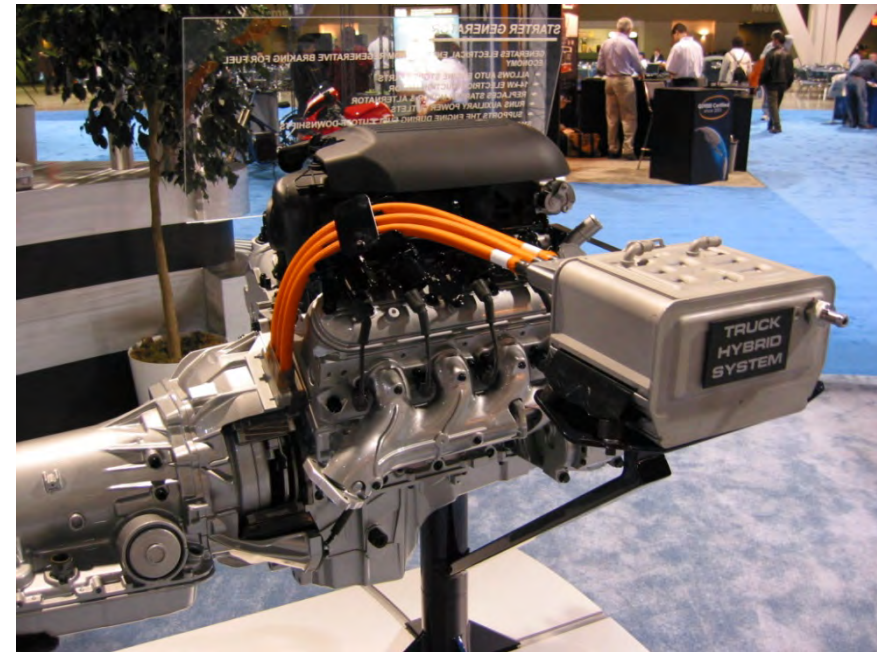

Co-funded by the
Erasmus+ Programme
of the European Union

FOR EDUCATIONAL PURPOSE ONLY

Volkswagen Touareg „P2“



Hybrid Powertrain



Touareg Hybrid



P2-Hybrid, 279 kW system power
3.0L V6 TSI, 35 kW electric motor
8.2 L/100 km, 0-100 km/h: 6.5 s



Co-funded by the
Erasmus+ Programme
of the European Union

VW 1-Liter Auto (Piech)



Volkswagen X1



Fuel Consumption: 0,9 l/100 km (combined)
CO₂-Emissions: 21 g/km (combined)
Price: > 110.000.-€



Co-funded by the
Erasmus+ Programme
of the European Union

Mercedes-Benz S 500 Plug-In P2 Hybrid



245 + 80 kW
480 + 340 Nm
30 km electrical range
3 l/100km 69 g CO₂

S 500 Plug-In Hybrid



Gasoline, 80 kW e-motor

P2-Hybrid, system power unknown
3.5L V6

3.2 L/100 km,
0-100 km/h: 5.5 s

- S-Class sales 2013: 10% Hybrid share (60% to China, 25 % to US)



Co-funded by the
Erasmus+ Programme
of the European Union

Mercedes S 400 Hybrid

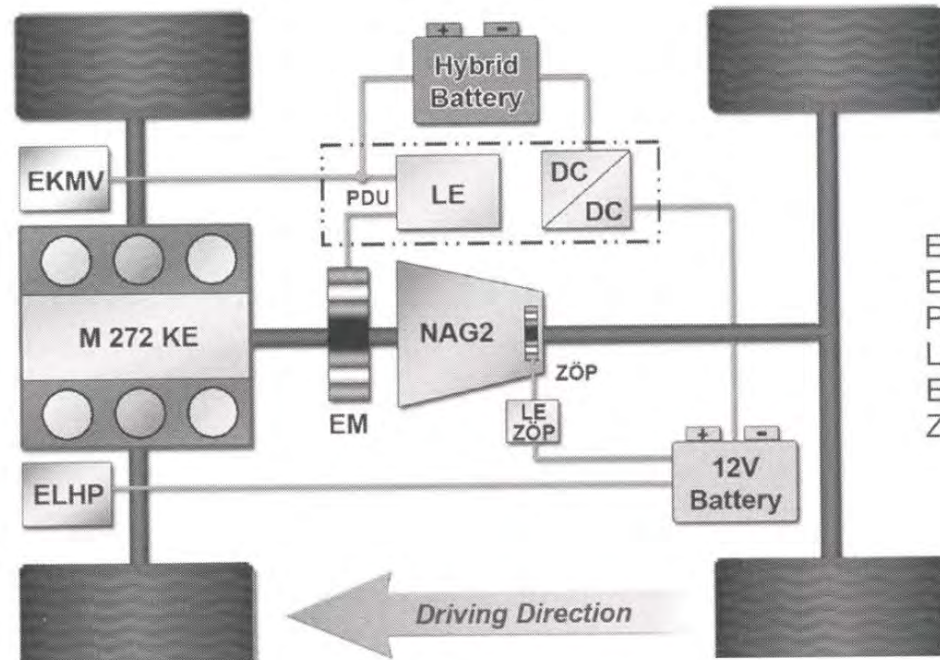

EKMV = Elektrischer AC Kompressor
 ELHP = Elektrische Lenkpumpe
 PDU = Leistungsverteilungseinheit
 LE = Leistungselektronik
 EM = Elektromotor
 ZÖP = elektrische Ölpumpe

Hybridsystem des Mercedes-Benz S 400 HYBRID [125]

Magna Power Hybrid Prototype HySUV (TM) - Powertrain concept

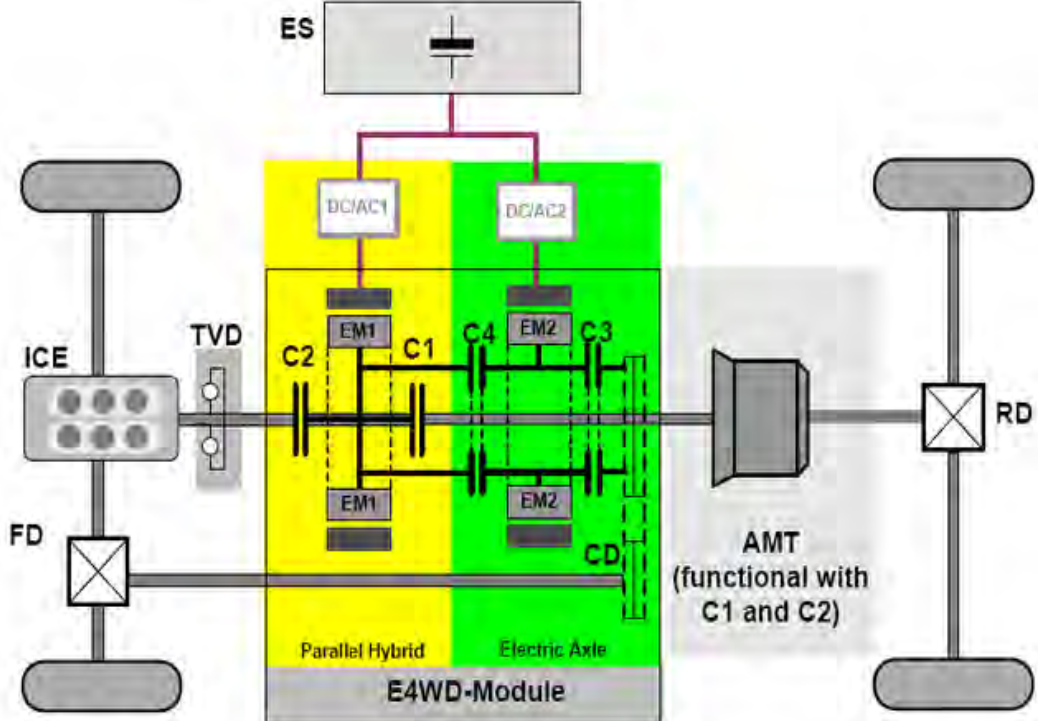

- | | | | |
|--------------|--------------------------|------------|-------------------------------|
| EMx | Electric machine(s) | AMT | Automatic manual transmission |
| ES | Energy storage (battery) | RD | Rear axle differential |
| DC/AC | Power electronics | ICE | Combustion engine |
| Cx | Clutch(es) | TVD | Torsion vibration damper |
| FD | Front axle differential | CD | Chain drive |

Magna Prototype HiCEPS Parallel Hybrid "P4"

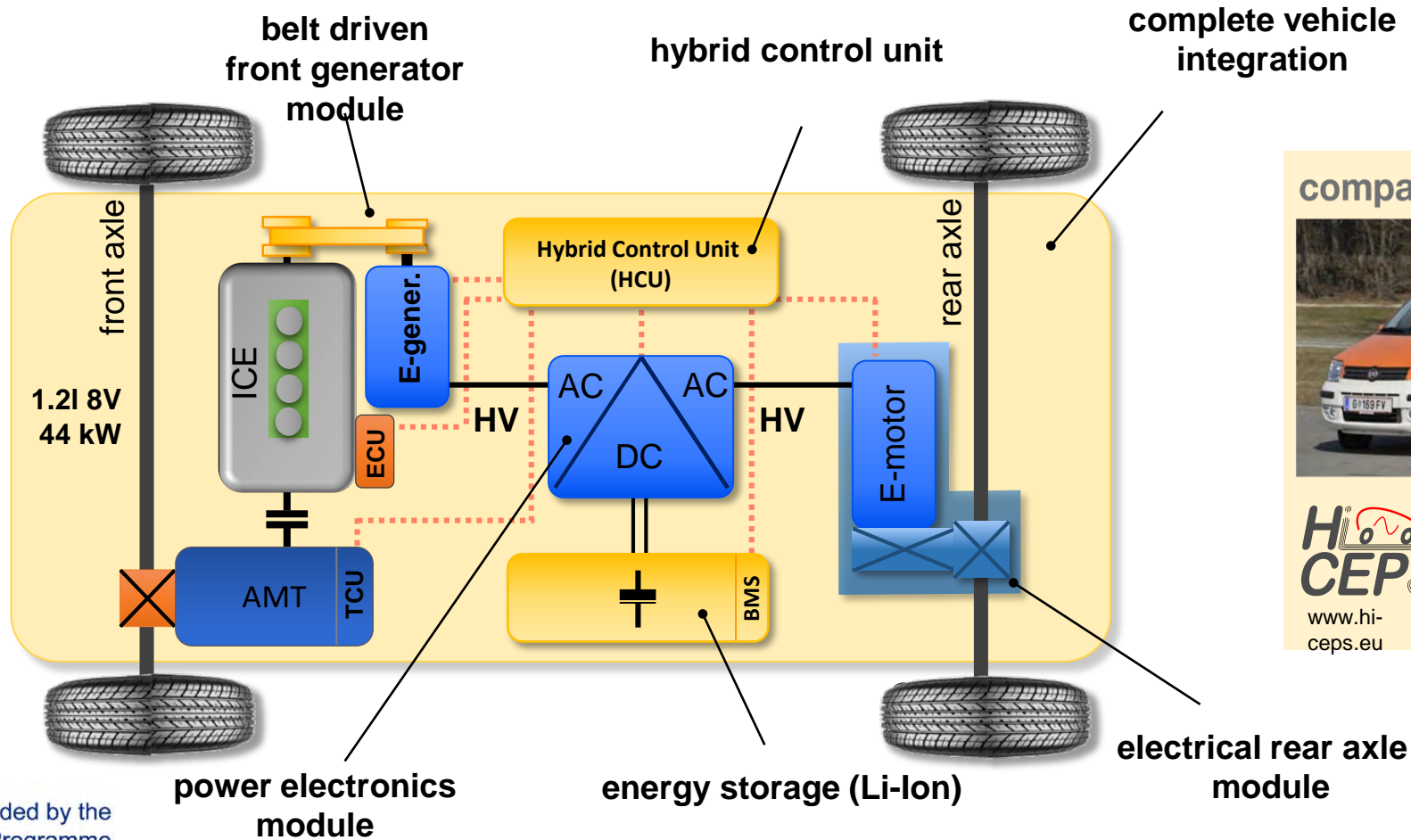

compactcityhybrid^{e4WD}



HiCEPS
www.hi-ceps.eu



Co-funded by the
Erasmus+ Programme
of the European Union

FOR EDUCATIONAL PURPOSE ONLY



HiCEPS Components & Integration

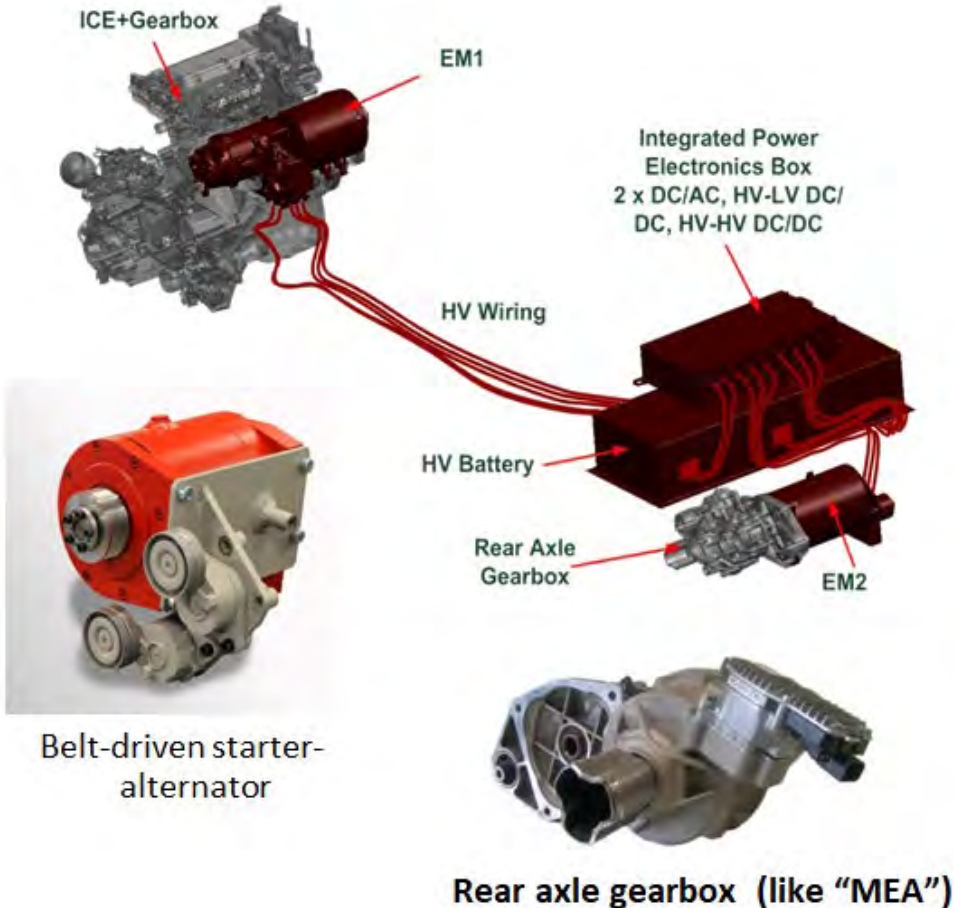

Modular, scalable concept with minimal changes at mass produced vehicle



Audi Q5 P2 Hybrid



Erste Serienanwendung im
Audi Q5 Hybrid Quattro
BMW Active Hybrid 5



15

Andreas Ratte, ZF Friedrichshafen AG, Germany

© ZF Sachs AG

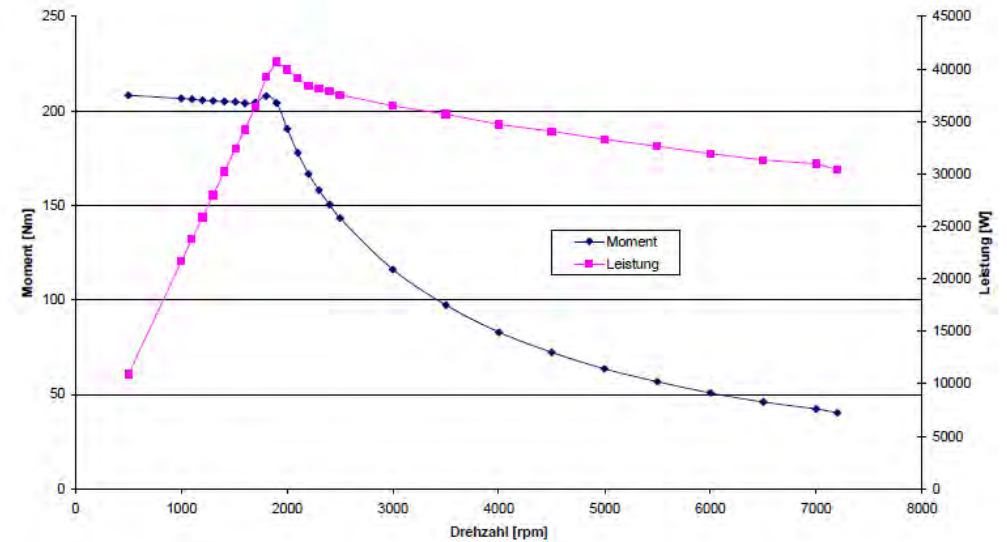

Gearbox and EM characteristics Audi Q5 [Ratte]

[Ratte] Ratte A.: Erweiterung eines 8-Gang Automatikgetriebes zum Vollhybridgetriebe. E-Motive Expertenforum "Elektrische Fahrzeugantriebe", Sept. 12th -13th 2012, Stuttgart.



Co-funded by the
Erasmus+ Programme
of the European Union

Audi Q5 Hybrid (cont.)



Electrical features:

- max 3 km AER
- Max. 100 km/h
- Li-Ion 72 cells, 266V
- +14000 Euro

Audi Q5 Drivetrain [Ratte]



Opel Ampera – a power split hybrid



Leistung: 111 kW
Drehmoment: 370 Nm
Höchstgeschwindigkeit: 160 km/h
Beschleunigung (0-100 km/h): < 10 s
Energieinhalt (Batterie): 16 kWh
Ladezeit: 4 - 6h @ 230 V, 16 A
Reichweite (batterie-elektrisch): 40 - 80 km
(gesamt): >500 km

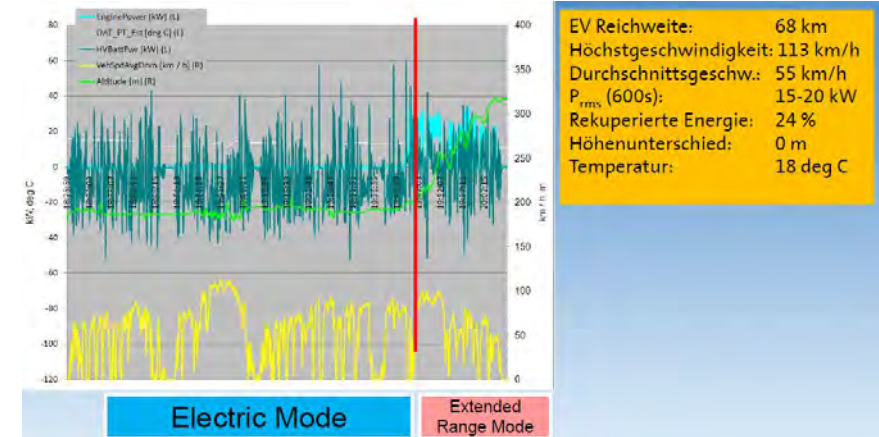

Opel Ampera Vehicle Data [Herrm]

<http://www.voltstats.net>: collecting data

[Herrm] Herrmann M.: Erfahrungen und Daten zu Batterie und Fahrzeug aus dem Betrieb des Opel Ampera. E-Motive Expertenforum "Elektrische Fahrzeugantriebe", Sept. 12th -13th 2012, Stuttgart.



Co-funded by the Erasmus+ Programme of the European Union

FOR EDUCATIONAL PURPOSE ONLY

Opel Ampera – a power split hybrid

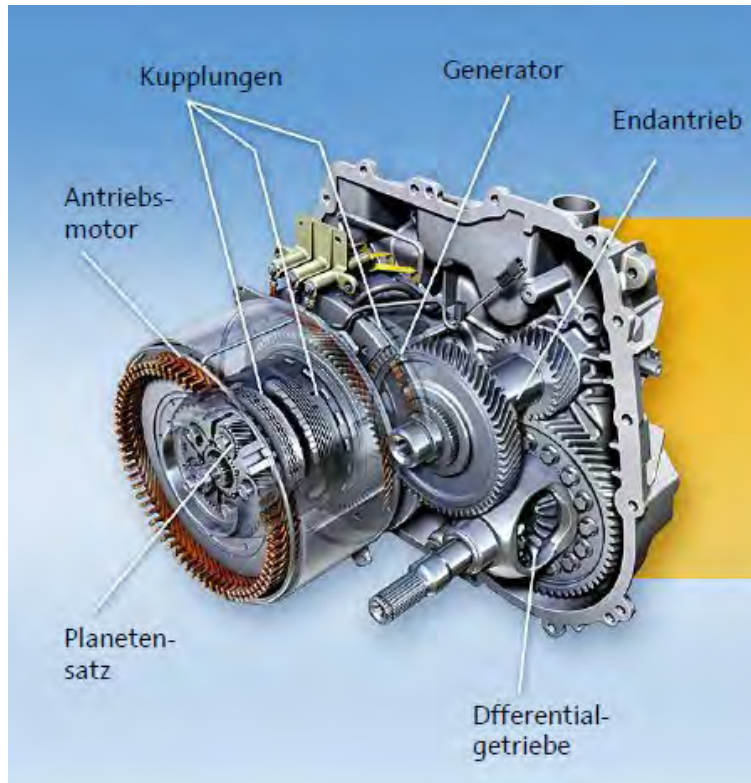

Electrified Powertrain: Power Split 2 E-machines integrated into the gearbox .

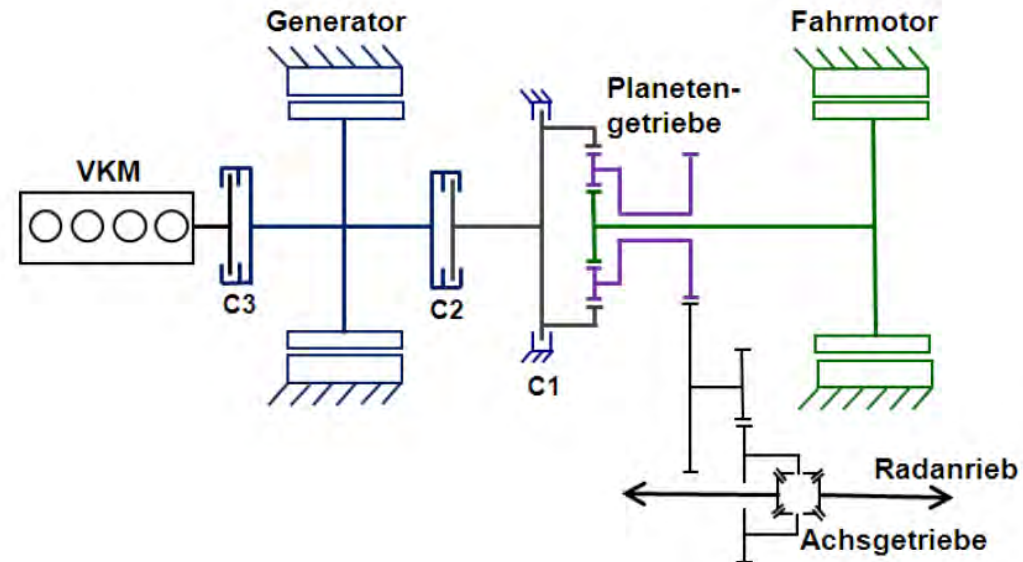

Opel Ampera Gearbox

**2 E-Machines: Mot: 111kW, 370 Nm
Gen: 54 kW, planetary gear box**



VW/Audi Electrification Strategy



Electrification Steps

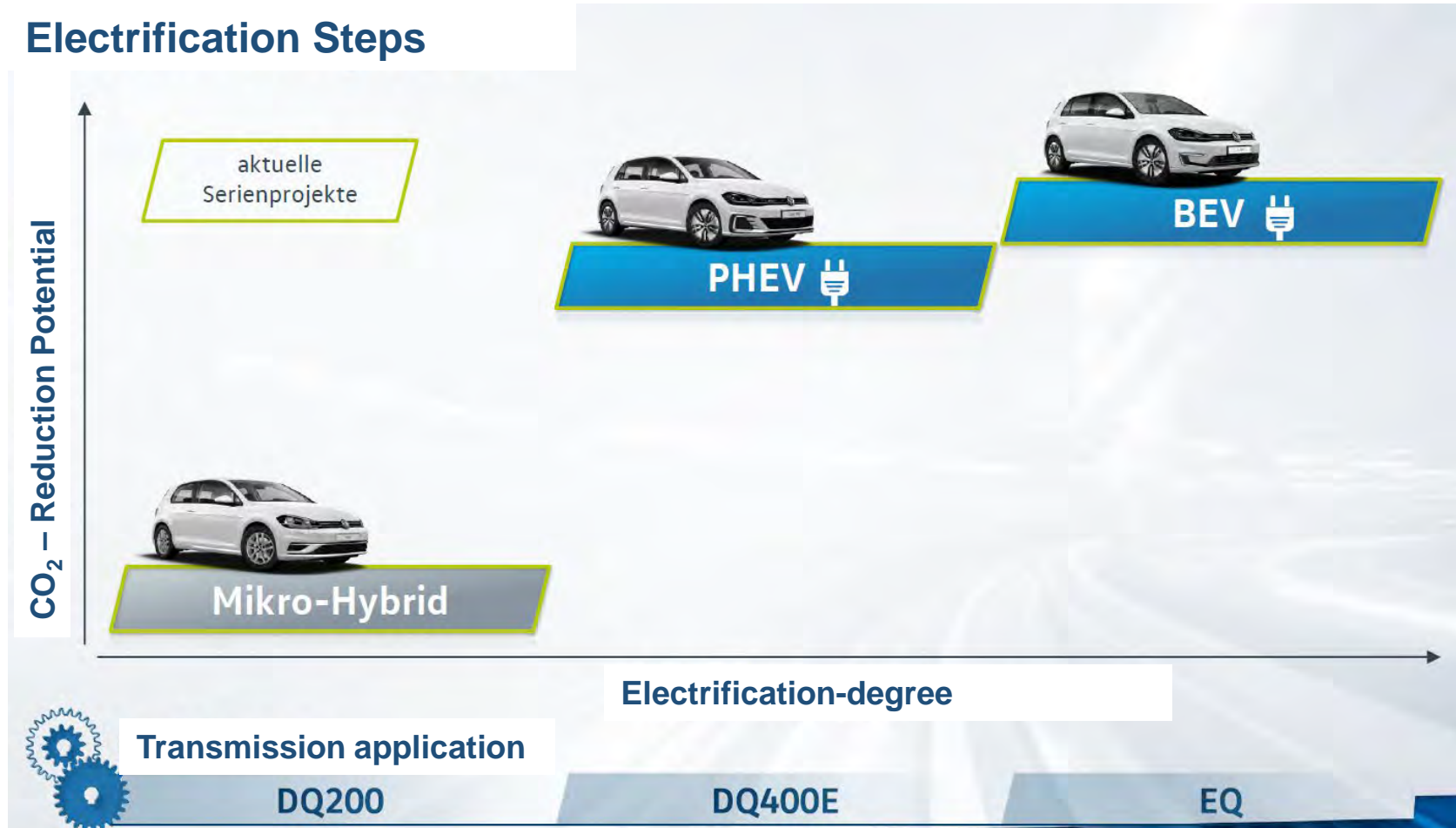

Co-funded by the
Erasmus+ Programme
of the European Union

VW's Micro Hybrids



Mikro-Hybrid – Components of the FMA- System

Engine stalled =

ZERO
Emission

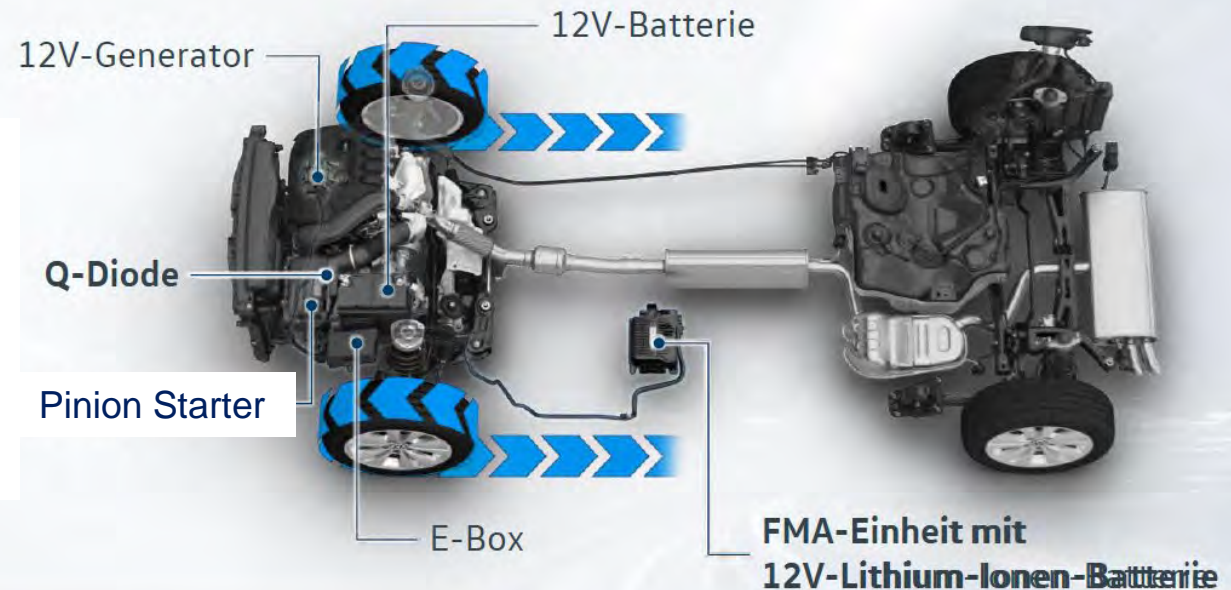

» Customer Benefits:

- Sailing with stopped ice
- Fuel consumption saving ~ 0.4 Lit/100 km

FMA: Freilauf Motor Aus



Co-funded by the
Erasmus+ Programme
of the European Union

VW's 48 Mild Hybrids

48V Mild Hybrid Plus (e- AWD)

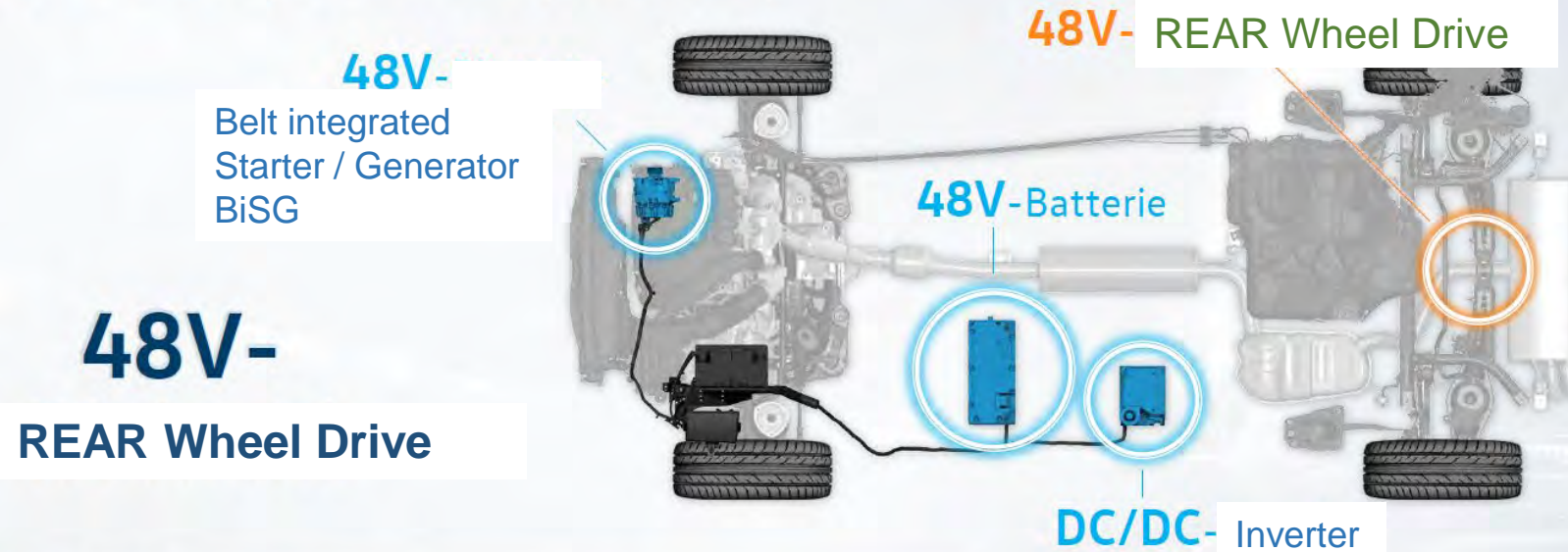

48V-
REAR Wheel Drive

» Customer Benefits:

- All benefits of mild HEV
- + electric creeping, parking
- + electric driving @at low speeds
- + traction support @ rear axle



Actual VW BEVs and PHEVs („GTE“)



Mikro-Hybrid	PHEV 	BEV 
<p data-bbox="484 521 573 556">Golf</p> <p data-bbox="624 549 955 749">TSI BLUEMOTION mit FMA</p>  <p data-bbox="611 1249 853 1278">FMA: Freilauf Motor Aus</p>	<p data-bbox="1108 521 1248 606">Golf GTE</p>  <p data-bbox="1108 921 1248 1006">Passat GTE</p> 	<p data-bbox="1745 528 1936 564">e-GOLF</p>  <p data-bbox="1745 921 1898 971">e-up!</p> 



Co-funded by the Erasmus+ Programme of the European Union

VW Golf GTE Plug-In Powertrain



Plug-In Hybrid



Plug-In Hybrid Power train
mit DQ400E

Internal combustion engine
1,4i TSI 110 kW

Transmission

Getriebe DQ400E
inklusive E-Maschine
(80 kW)



- 60 % CO₂



Co-funded by the
Erasmus+ Programme
of the European Union

VW's Dedicated Hybrid Transmission



DQ400E

- Fest-/Loslagerung
- Motortrennkupplung [K0] im E-Betrieb betätigungskraftfrei
- Energiesparhydraulik
- Doppelkupplung CSC betätigt
- aktive Radsatzschmierung und Kupplungskühlung
- Integration der el.-Antriebsmaschine (HEM80, 80 kW)
- max. Momentenkapazität = 400 Nm



Co-funded by the
Erasmus+ Programme
of the European Union

VWs High Voltage PHEV

Plug-In-Hybrid (Hochvolt) – DQ400E

High Voltage Motor

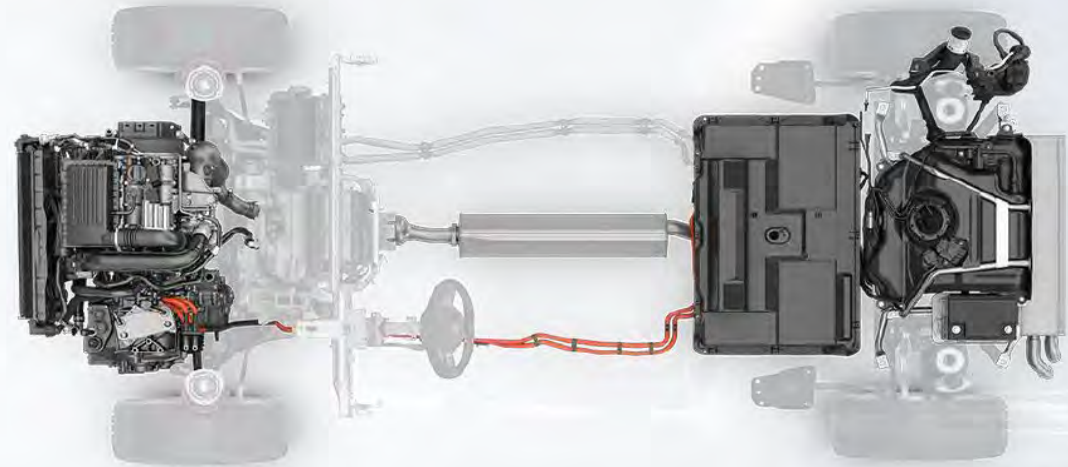

» Customer Benefits:

- Electric/emission free driving up to 50 km
- External charging possibility
- Enhanced dynamics
- Fuel consumption reduction



Mitsubishi Outlander Plug-In Hybrid



PHEV

- ICE 4 Cyl, 2.0L 87 kW/185 Nm
- eMotor PSM 60kW 137 Nm f
- eMotor PSM 60kW 195 Nm
- Battery 12 kWh Li-Ion
- Voltage 300V

PHEV SYSTEM

Because of its unique drivetrain which combines a front electric motor, rear electric motor, front-mounted gasoline-powered 2.0-liter engine and generator, the Outlander PHEV automatically selects one of three unique drivetrain modes for optimal performance and efficiency.



EV MODE

In the EV Mode, the vehicle is driven by the two electric motors, with energy being supplied exclusively by the lithium-ion drive battery pack (100 percent electric-powered, zero-emission vehicle). This mode is excellent for running daily errands while having a low environmental impact. The EV mode button can be selected for 100% EV driving, if desired.



SERIES HYBRID MODE

When the charge in the battery pack is low, or when the need arises for a more sudden and/or additional degree of acceleration, the two electric motors are powered by the battery pack and the gasoline-powered generator. In Series Hybrid Mode, the gasoline-powered generator helps charge the lithium-ion drive battery pack and provide power to the pair of electric motors.



PARALLEL HYBRID MODE

In Parallel Hybrid Mode, the 2.0-liter gasoline engine drives the front wheels. The front axle features a built-in clutch that switches the system to Parallel Drive Mode. The two twin electric motors operate seamlessly when additional power is required, such as driving uphill. The gasoline-powered engine then feeds any excess electricity back into the lithium-ion drive battery pack.



Co-funded by the
Erasmus+ Programme
of the European Union

Further hybrids on the market

Toyota Prius PHEV

- Range electrical: 20km
- ICE Gasoline : 73kW
- Electric traction motor: 60kW
- Li-ION Battery: 5,2kWh
- Power Split Gearbox

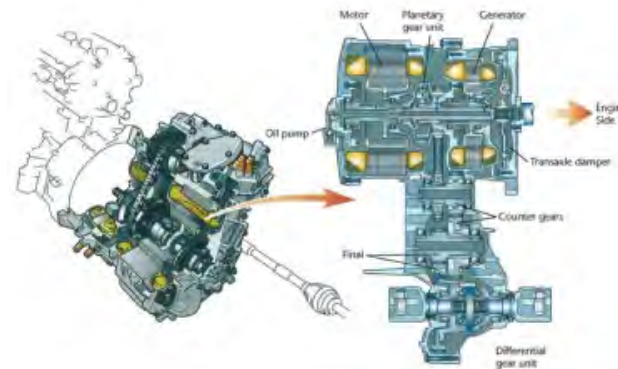

Volvo V60 Hybrid P4 with CISA

- Range electrical: 50km
- ICE Diesel: 158kW
- Electric traction motor: 50kW
- Li-ION Battery: 12kWh
- Front CiSA Generator
- 6-Speed Automatic transmission





Engineering Knowledge Transfer Units to Increase Student's Employability and Regional Development



<https://www.facebook.com/unitederasmus/>



Co-funded by the
Erasmus+ Programme
of the European Union

This project has been funded with support from the European Commission. This publication reflects the views only of the author, and the Commission cannot be held responsible for any use which may be made of the information contained therein.
598710-EPP-1-2018-1-AT-EPPKA2-CBHE-JP

FOR EDUCATIONAL PURPOSE ONLY



Engineering Knowledge Transfer Units to Increase
Student's Employability and Regional Development

Options for a CO₂ reduced Mobility

Energy management and Storage Options



Co-funded by the
Erasmus+ Programme
of the European Union

This project has been funded with support from the European Commission. This publication reflects the views only of the author, and the Commission cannot be held responsible for any use which may be made of the information contained therein.
598710-EPP-1-2018-1-AT-EPPKA2-CBHE-JP

FOR EDUCATIONAL PURPOSE ONLY

Advanced Powertrains: Success depends on smart energy management!!!

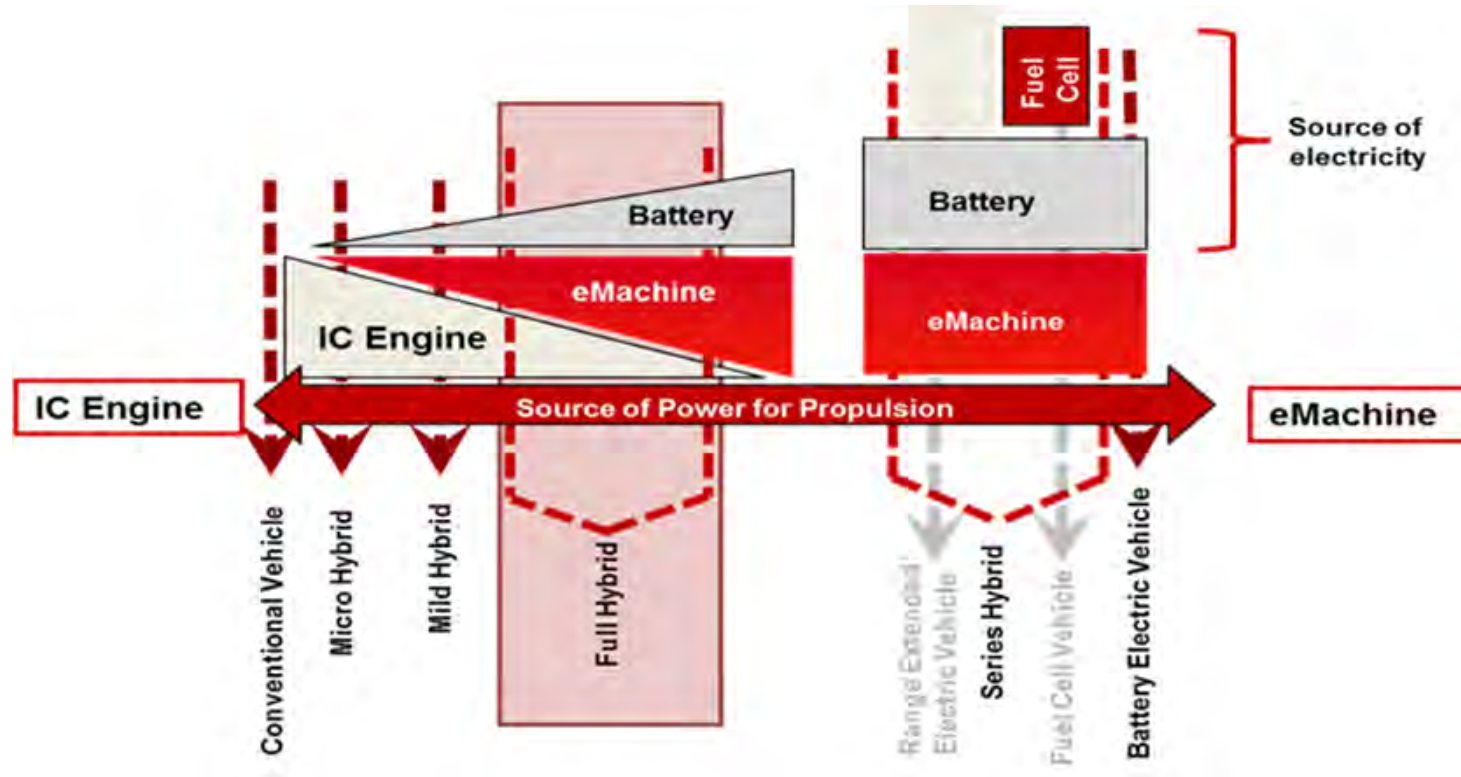

Highly complex task with the big variety of powertrain options!

Energy management / Operating Strategies



Besides fulfilling the driver's wish the energy management accomplishes the following requirements:

- **Coordination of all relevant functions depending on actual conditions**
- **Operational strategies for the main propulsion components considering:**
 - SOC state of charge
 - Life time expectation of the battery
 - Temperature condition of e-motor and battery
- **Targets :**
 - Reduction of energy (and/or ICE fuel) consumption (and emissions)
 - Enhance driving dynamics and driving experience
 - Higher comfort



Energy management / Operating Strategies



Energy management with EVs, Hybrids and FCVs covers:

- **Operational strategies of the main propulsion components :**
 - ICE
 - E-motors, Inverters, batteries
 - Transmissions
 - Fuel cell
 - When to operate and how?
- **Cooling of the main propulsion components, heating, air conditioning**
 - Thermal vehicle management
- **Auxiliary management, electric components, communication, infotainment**
 - Electrical energy supply (board net) management
 - “Demand driven”



Co-funded by the
Erasmus+ Programme
of the European Union

Operating Strategies / Energy management



Energy management with EVs, Hybrids and FCVs requires:

- **A comprehensive view on the total vehicle system**
- **Well trained understanding of all processes, functions and their interactions**
 - Usually by extensive simulations
- **Vehicle controller VCU with software accounting to all processes, supervising component controllers**
- **Simulation or model based control algorithms**
 - Advanced powertrains have in any operating mode and point a more complex structure than conventional powertrains.
 - This refers also to the actual efficiency chain in the very moment
 - The task is to optimize the total efficiency for each operating situation!!
 - >> sometimes “Cost functions” are applied for optimization!



Co-funded by the
Erasmus+ Programme
of the European Union

Simulation Model of a HEV

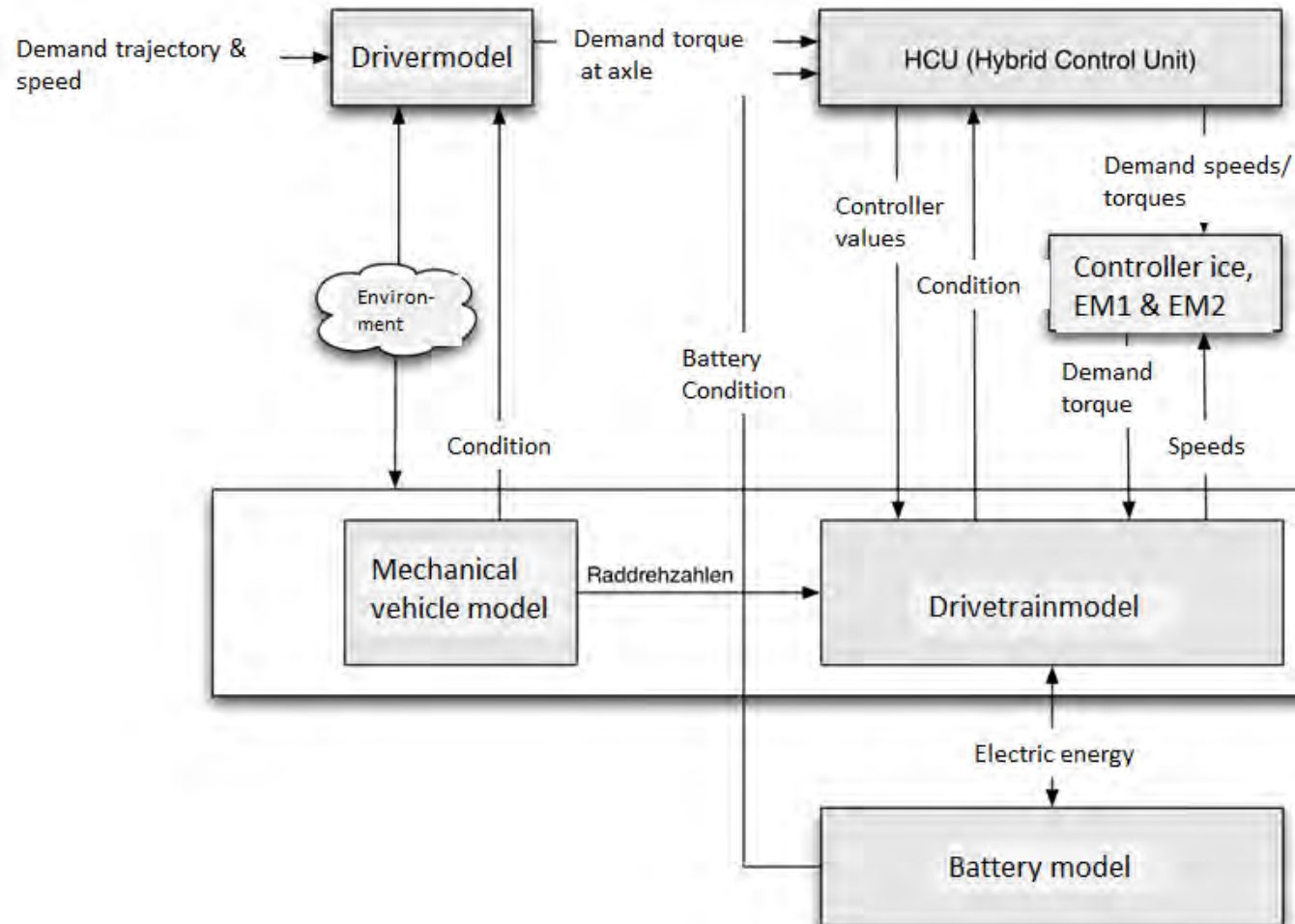

Energy management / Operating Strategies



The Energy Management (Vehicle Controller (VCU)) needs further to consider:

Input - Parameters:

- **Driver wishes**: pedal positions (accel. & brake, forward, reverse, operating mode wish)
- **System internal data**: current speeds and torques of the machines, **battery SOC**, temperatures, alignment with internal models, simulations, etc
- **Learnt or forecasted data** (GPS): recent history, routes , topography
- **Energy profile of frequently used routes**

And generate the Output commands: demand values to the components

- **ICE**: on/off; demand-operating point (throttle position)
- **Electro motors**: on/off, rotating direction, demand torque or speed control, required torque and/or speed
- **Auxiliaries management**



Co-funded by the
Erasmus+ Programme
of the European Union

Operating strategies with forecast - functions

Operating strategies with forecast functions

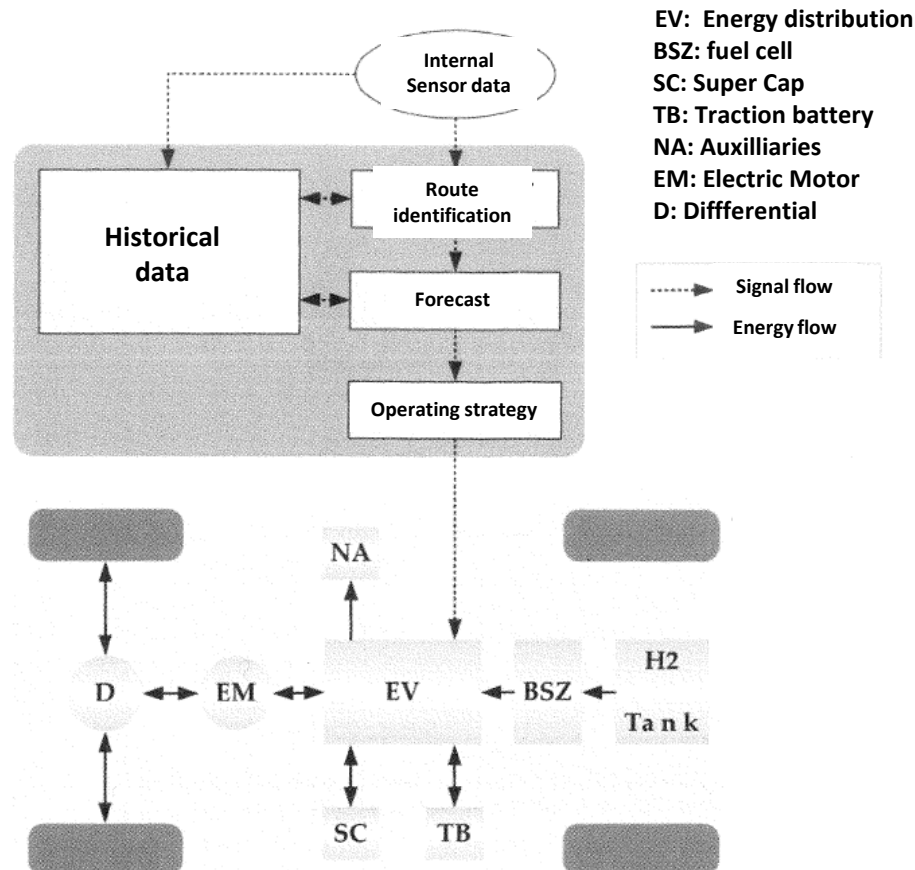

- Learning/forecasting of tours can be achieved by analysing speed and steering angle profiles
- **The potential for forecasted tours lies in the increase of brake energy recovery and better battery management**

Source: Hofmann
Hybridfahrzeuge Springer

Energy management / Operating Strategies



Energy management with EVs covers:

- **Operational strategies of the main propulsion components :**
 - E-motors, Inverters, batteries
 - (Transmissions, only when multiple shift (seldom))

- **Cooling of the main propulsion components, heating, air conditioning**
 - Thermal vehicle management (important!)

- **Auxiliary management, electric components, communication, infotainment**
 - **Electrical energy supply (bord net) management**



Energy management / Operating Strategies



Energy management with EVs covers:

- Operational strategies of the main propulsion components :
 - E-motors, Inverters, batteries
 - (Transmissions, only when multiple shift (seldom))

- Cooling of the main propulsion components, heating, air conditioning
 - Thermal vehicle management (important!)

- Auxiliary management, electric components, communication, infotainment
 - Electrical energy supply (bord net) management



Co-funded by the
Erasmus+ Programme
of the European Union

Operation Mode – Recuperation brake energy



The function of regenerative braking systems is to recover and recycle as much of braking energy as possible.

Energy recuperation potential depends on:

- Driving Profile (Driving Cycle)
- Vehicle Mass
- Tire Rolling Resistance
- Aerodynamic Drag

and is **limited by the power of e-motor** (max kW) **and inverter** (max. Amperes) and the ability of the battery to adsorb energy quickly!

→ Positive effect: The total tractive energy, that must be directly provided by the e-motor, is reduced.



Co-funded by the
Erasmus+ Programme
of the European Union

Gino Sovran and Dwight Blaser: Quantifying the Potential Impacts of Regenerative Braking on a Vehicle's Tractive-Fuel Consumption for the U.S., European, and Japanese Driving Schedules. 2006, SAE

Instantaneous tractive-force requirement for vehicle on level road



$$F_{TR} = R + D + \left[M + 4 \cdot \left(\frac{I_w}{r_w^2} \right) \right] \left(\frac{dV}{dt} \right)$$

$$F_{TR} = \underbrace{r_o \cdot M \cdot g}_{\text{tire resistance}} + \underbrace{C_D \cdot A \frac{V^2}{2} \cdot \rho}_{\text{aerodynamic drag}} + \underbrace{M_e}_{\text{linear and rotational inertia}} \cdot \left(\frac{dV}{dt} \right)$$

- R ... tire rolling-resistance force in N
- D ... aerodynamic drag force in N
- M ... vehicle mass in kg
- I_w ... polar moment of inertia of a wheel assembly in kgm^2
- r_w ... effective rolling radius in m
- r_o ...rolling resistance coefficient
- $g = 9.81 \text{ m/s}^2$
- C_D ... aerodynamic drag coefficient
- A ... vehicle frontal area in m^2
- ρ ... density of ambient air in kg/m^3

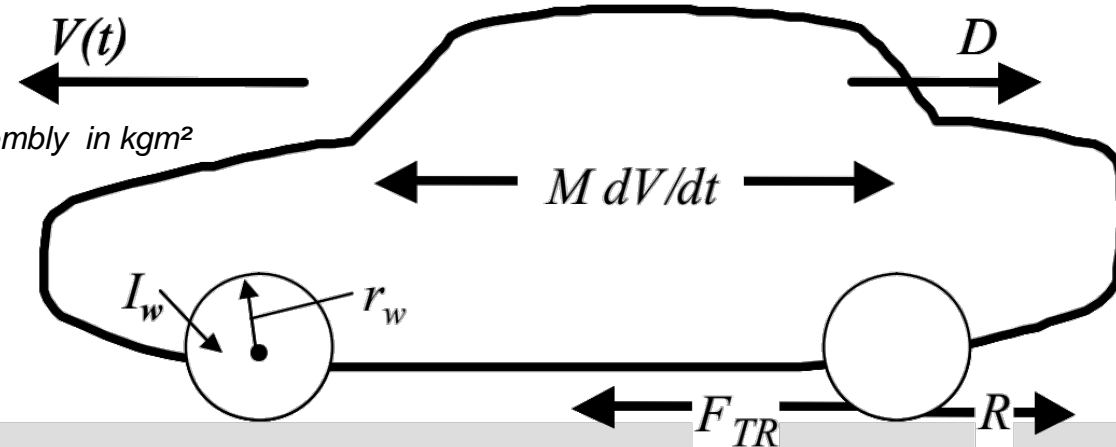

Instantaneous tractive-force requirement for vehicle on level road

$$F_{TR} = R + D + \left[M + 4 \cdot \left(\frac{I_w}{r_w^2} \right) \right] \left(\frac{dV}{dt} \right)$$

$(+)$ $(+)$ $(+/-)$

tire resistance aerodynamic drag linear and rotational inertia

$F_{TR} > 0$: Powered Driving
 $F_{TR} = 0$: Idling
 $F_{TR} < 0$: Braking

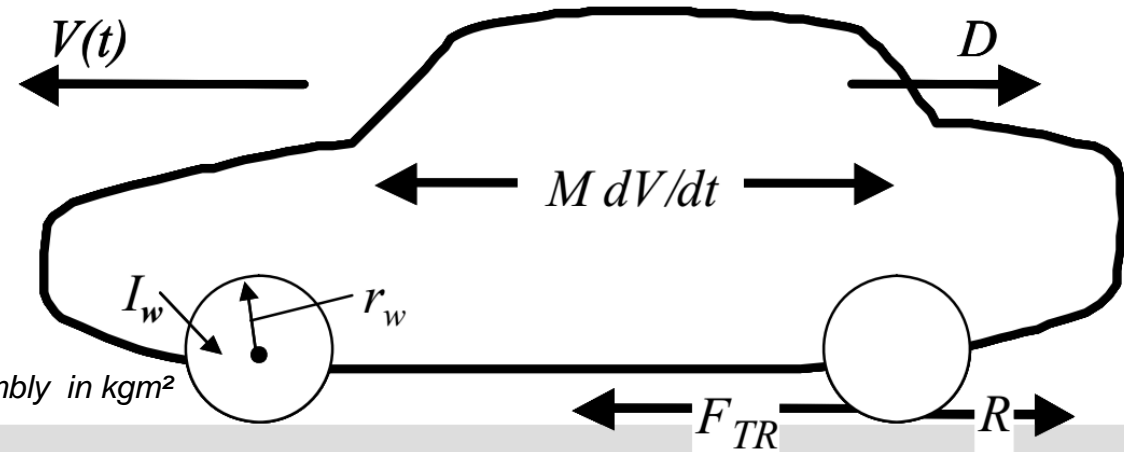

R ... tire rolling-resistance force in N
 D ... aerodynamic drag force in N
 M ... vehicle mass in kg
 I_w ... polar moment of inertia of a wheel assembly in kgm^2
 r_w ... effective rolling radius in m

Braking Energy

$$P_{TR} = F_{TR} \cdot V \rightarrow E_{BR} \equiv - \int_{F_{TR} < 0} P_{TR}(t) \cdot dt$$

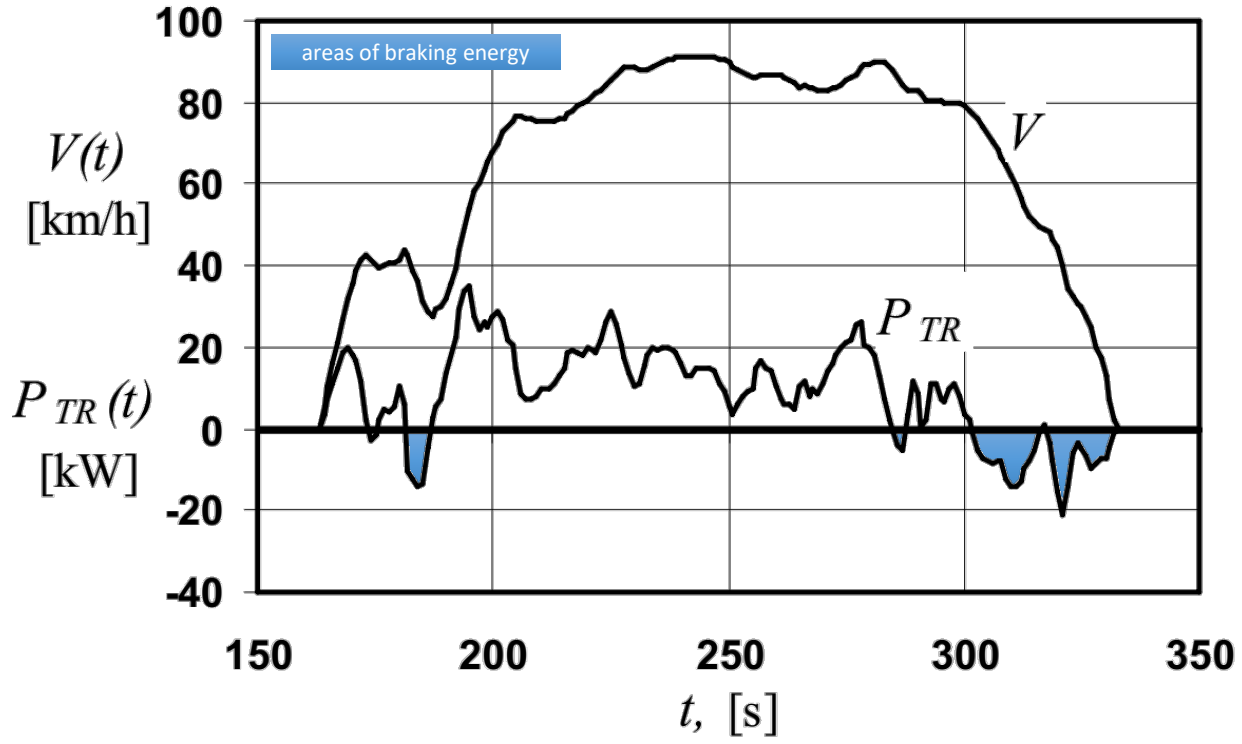

P_{TR} ...tractive power
 F_{TR} ... tractive force
 V ... vehicle velocity
 E_{BR} ... braking energy

Velocity and tractive power (element of US/EPA)

Gino Sovran and Dwight Blaser: Quantifying the Potential Impacts of Regenerative Braking on a Vehicle's Tractive-Fuel Consumption for the U.S., European, and Japanese Driving Schedules. 2006, SAE

Operation Mode – Recuperation of brake energy

Regenerated Energy for Supplementing Traction

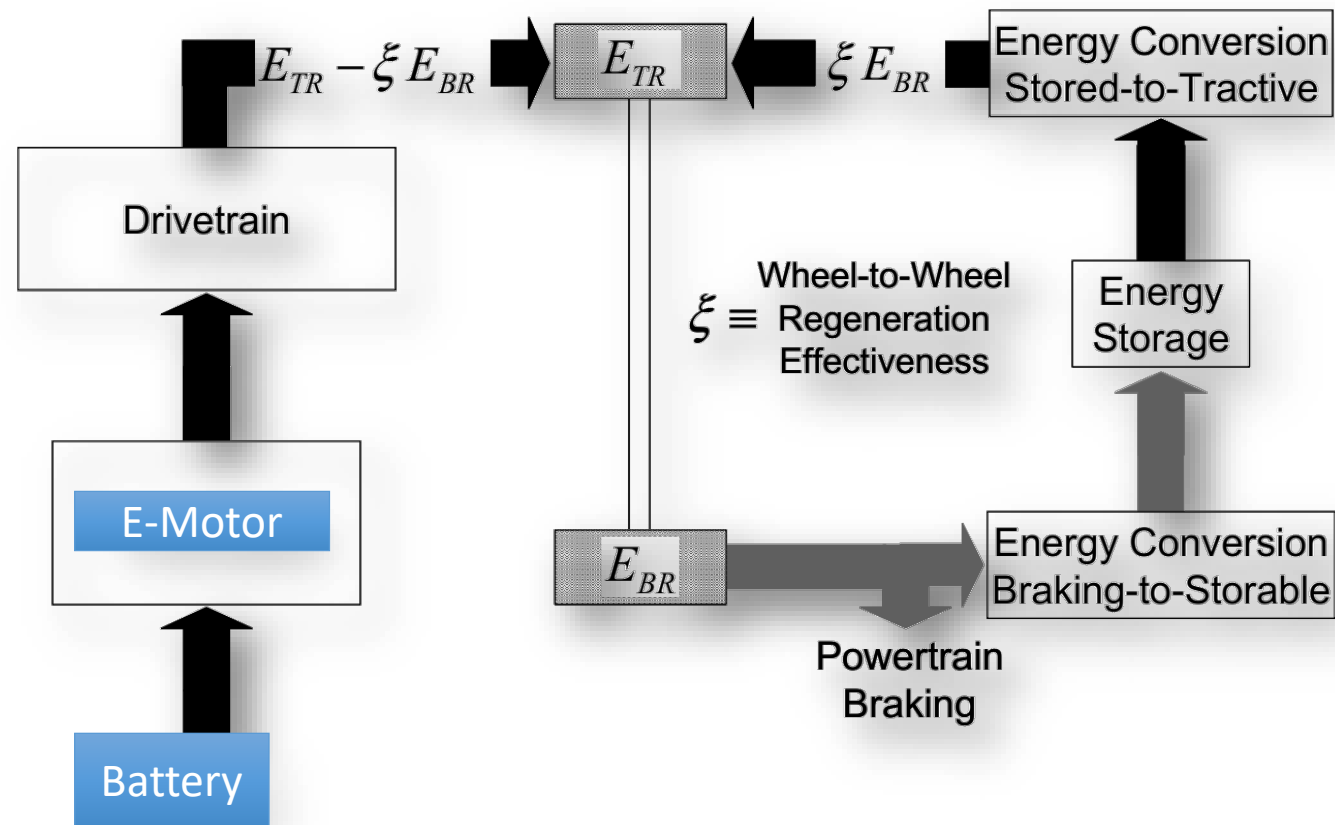

Thermal Management Electric Drive System Detailed Schematics

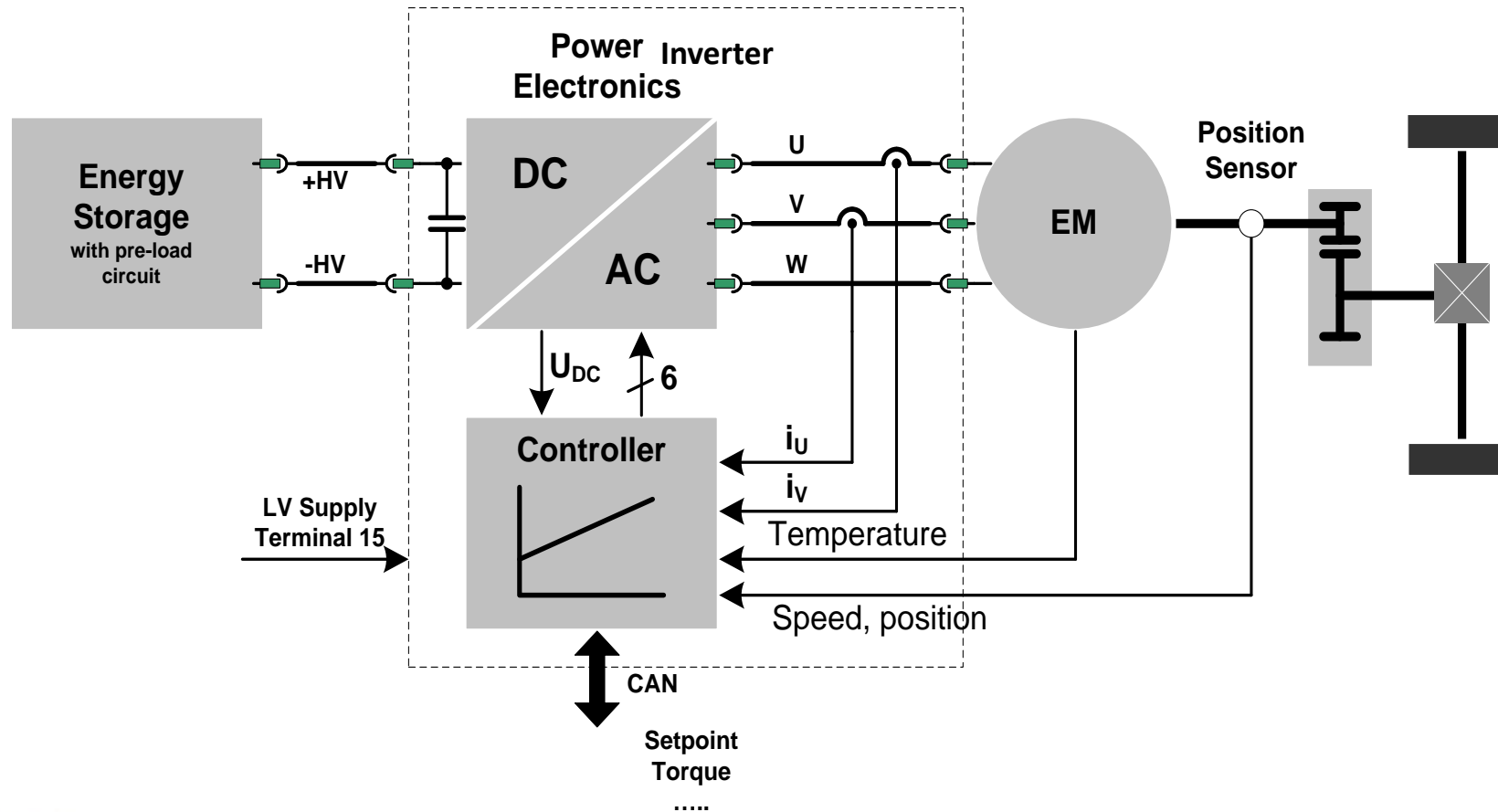

Battery, power electronic, and e-motor need cooling!

Thermal Management of EVs

Cooling of the electric Machines

Air cooling	Liquid cooling
No leaking Frost safe Low Weight	More complex package possible Low material temperatures Acoustics
	Higher heat current density

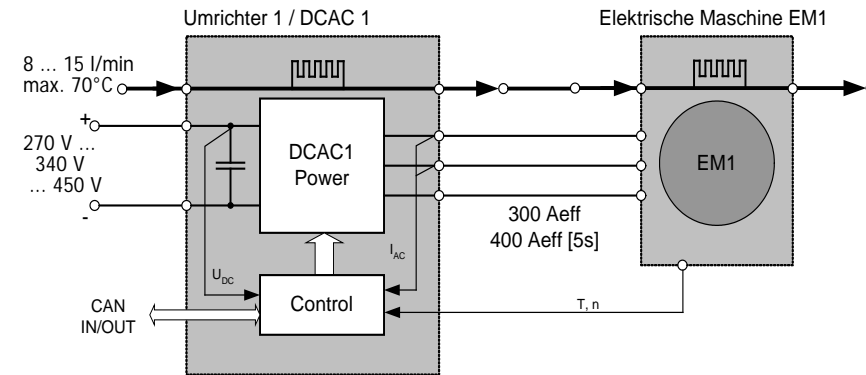

Losses & Temperature & Power

Keep cool

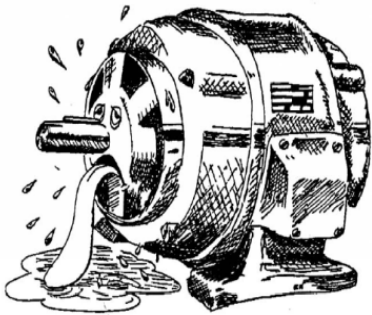

Electric machines:
air or **liquid** cooling
Power electronics:
liquid cooling

high thermal inertia!
no thermal inertia!
water/glycol

Liquid cooling is preferred for EVs,
Inverter need a cooler coolant and should be kept under 80°C!
So first with the coolant through the inverter and then into the e-motor which can bear higher temperatures i.e. ~105°C!

Thermal Management Power Electronics - Cooling

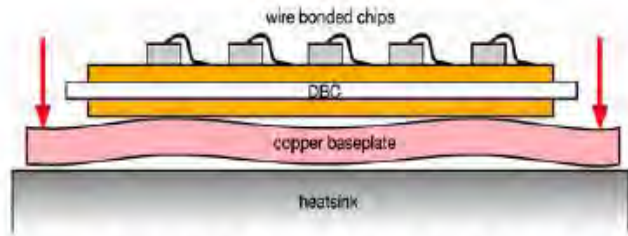

Standard module with base plate

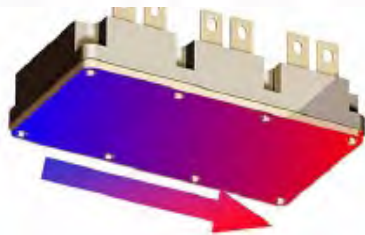

Cooling via Base Plate

- Water- Glycol
- max. Inlet Temp. 85°C

Challenge: homogeneous cooling

Solution : Shower Power i.e. Danfoss

Future development: "Hot Cooling"

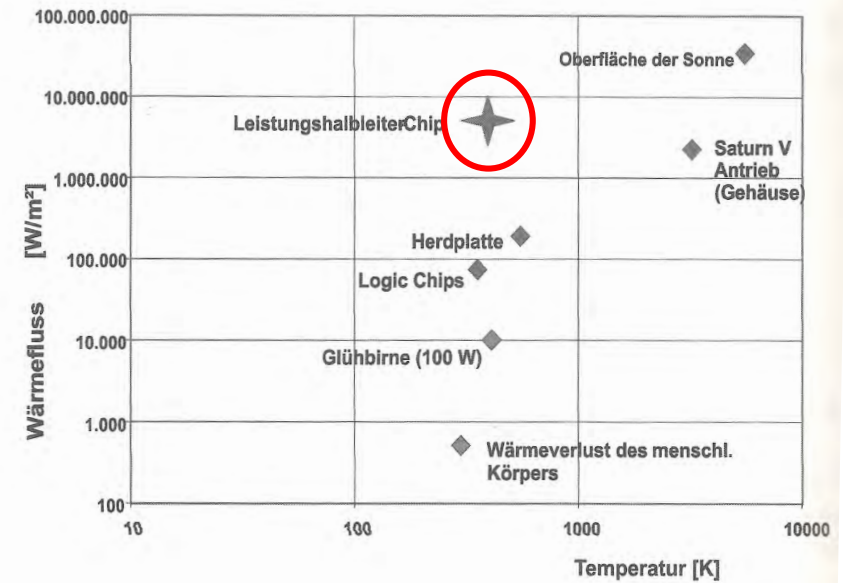

Double Sided Cooling



Source: Denso

Thermal Management Battery cooling options

Air Cooling

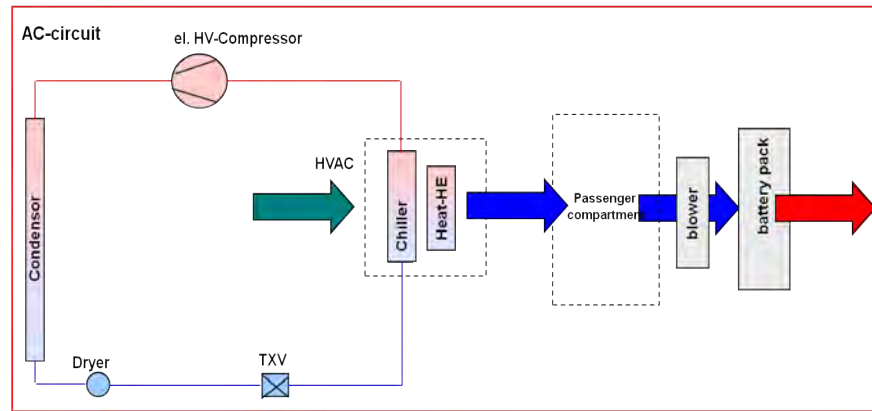

Liquid Cooling

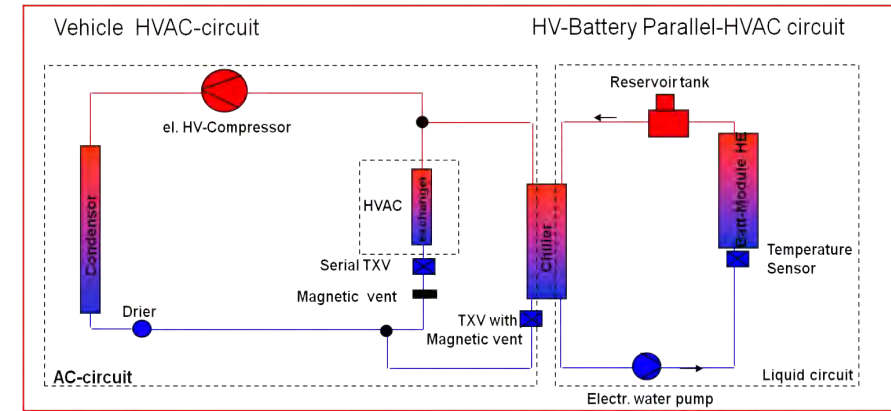

Advantage:

- no additional liquid cooling circuit
- cooling media is isolating

- Cooling performance well controllable
- Comfort (Noise)
- Safety (closed system)
- kompakt, flexible design

Disadvantage:

- Comfort (Noise)
- Safety not closed system
- Requires more space → higher Integration effort
- Cooling verhalten komplex

- Adaption of the existing cooling circuit
- additional cooling circuit
- Extra heating at low temperatures

Example: EV Thermal Management

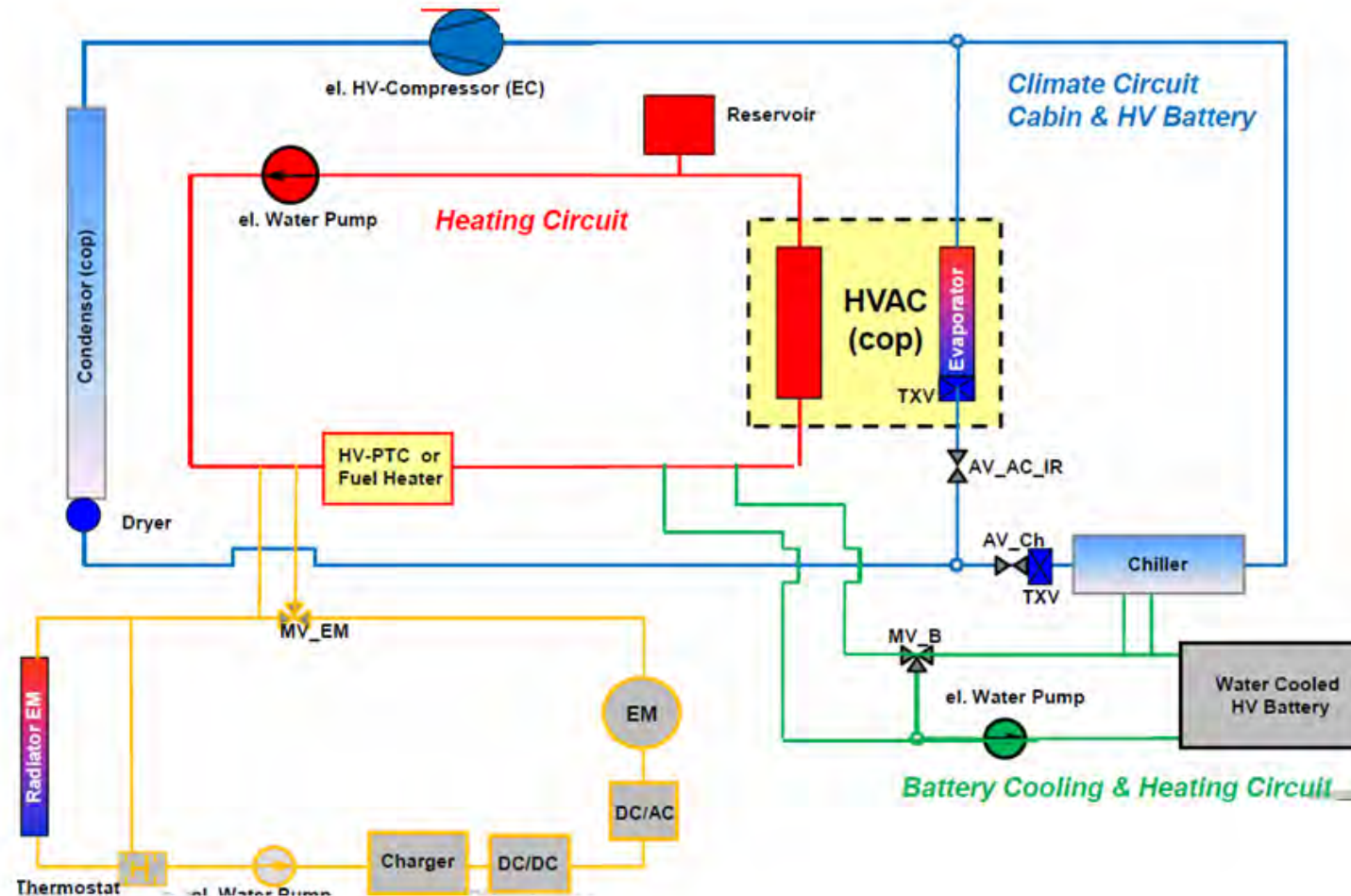

FC-EV Example FCREEV Thermal Management

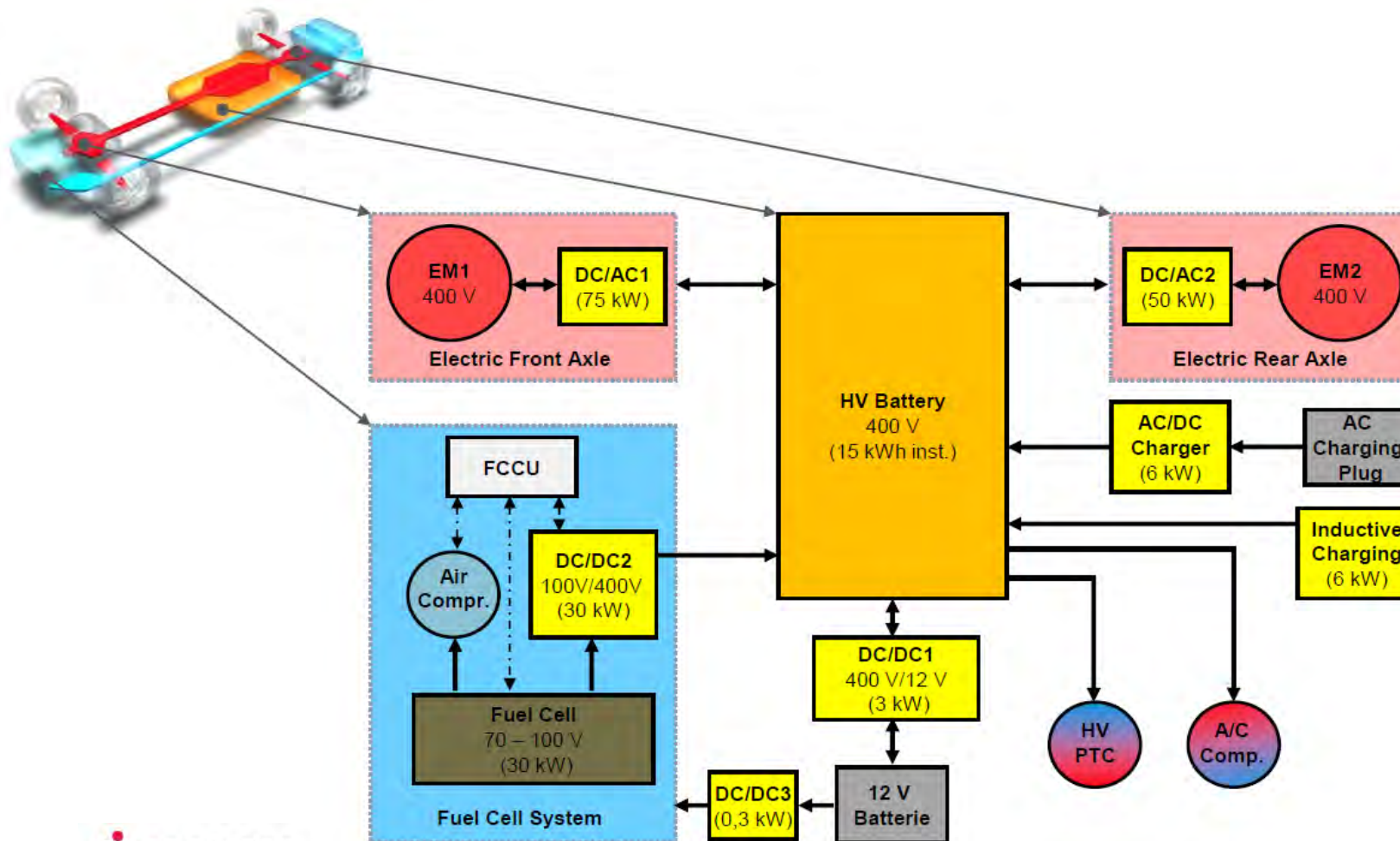

Co-funded by the
Erasmus+ Programme
of the European Union



R&D-ID: MSE-016

FOR EDUCATIONAL PURPOSE ONLY

FC-EV Example FCREEV Thermal Management

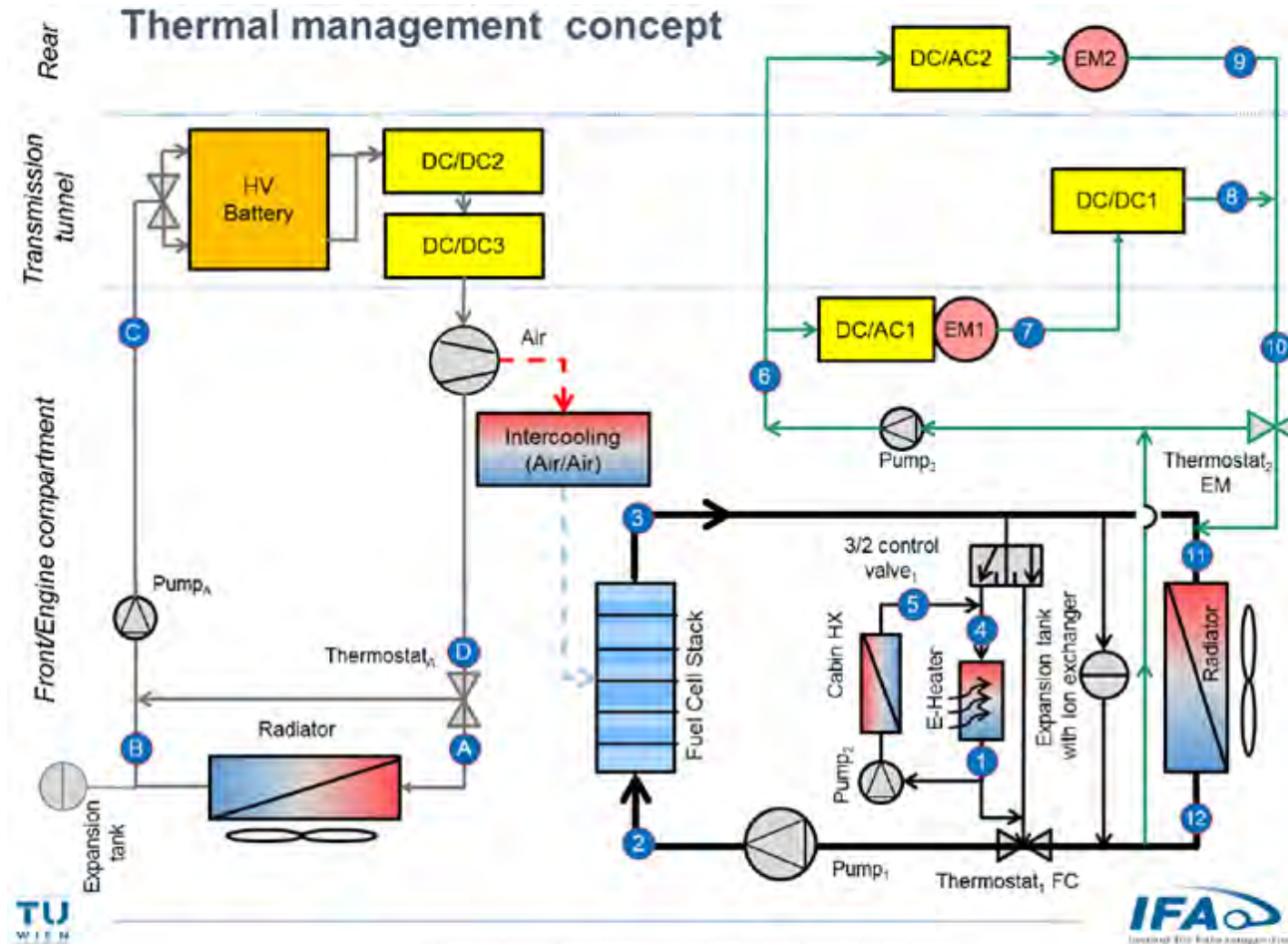

Thermal Management of EV - Comfort



Principles:

- Avoid too many cooling circuits (costs, weight!)
- Combine heat wells and consumers in a smart way!

Heating:

- Use of electric heating can reduce the range of an EV considerably
- Special regulations limit the usage of heating systems (US only below 4°C)
- Standard is PTC heater for EVs (currently)

Air conditioning:

- Standard air conditioning systems reduce the range of an EV considerably too
- HVAC used for battery cooling too
- **Future: Low energy heat pump systems**



Energy Management Hybrids - Basic Principles – a reminder



Hybrid powertrains have longer power paths with longer efficiency chains compared to the conventional and pure electric drives.

The powertrain efficiency depends on:

- selected hybrid architecture,
- efficiency of components,
- and the chosen operating strategy (new!).

Evaluation / „Common sense rules“

1. Any energy-transformation causes losses
2. (in-between) Storage of energy causes losses too
3. Operating big components in part load is not efficient

Most important is to assure the best possible EFFICIENCY in each operating point of the propulsion map (speed and torque @ wheel) !!!



Co-funded by the
Erasmus+ Programme
of the European Union

Energy management - Hybrids



Energy management with EVs, Hybrids and FCVs covers:

- **Operational strategies of the main propulsion components :**
 - ICE
 - E-motors, Inverters, batteries
 - Transmissions
 - When to operate and how?

- **Cooling of the main propulsion components, heating, air conditioning**
 - Thermal vehicle management

- **Auxiliary management, electric components, communication, infotainment**
 - **Electrical energy supply (board net) management**



Energy management Hybrids

Energy management with EVs, Hybrids and FCVs covers:

- **Operational strategies of the main propulsion components :**
 - ICE
 - E-motors, Inverters, batteries
 - Transmissions
 - When to operate and how?
- **Cooling of the main propulsion components, heating, air conditioning**
 - Thermal vehicle management
- **Auxiliary management, electric components, communication, infotainment**
 - Electrical energy supply (bord net) management



Controller Architecture of a Hybrid Vehicle

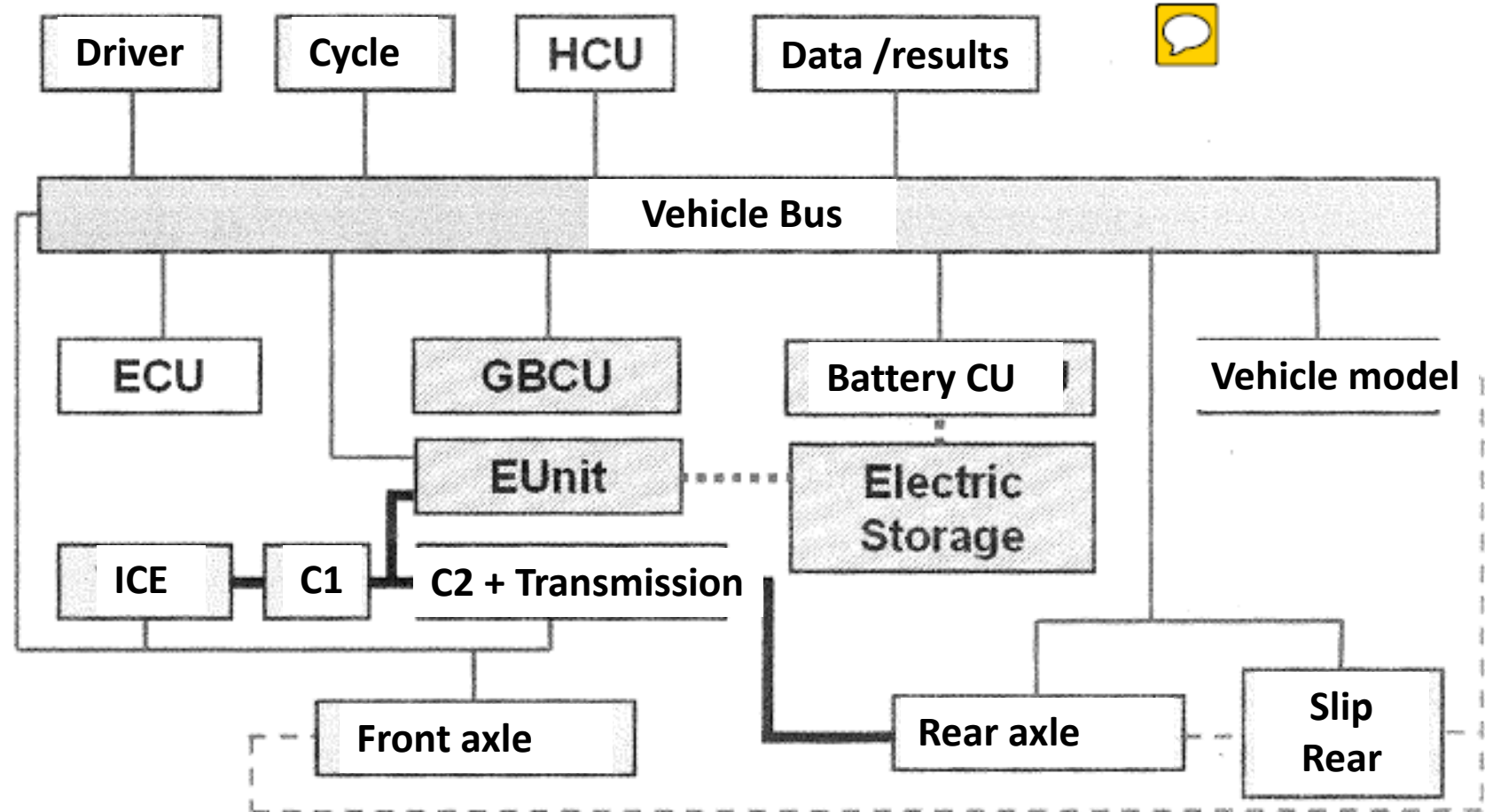

Hybrid powertrain – main operating modes



Following typical hybrid need to be realized by the hybrid control system:

- **Start / Stop Strategy**: engine shut-off of when vehicle is stalled and immediate ice start when touching throttle pedal
- **Recuperation**: recovery of braking energy by generator mode of the e-motor, charging of tractions battery while motoring the vehicle
- **„Boosting“**: short time adding of electric motor and ice torque for acceleration
- **Load shifting of ic-engine** : charging battery during driving by ic-engine (higher torque demand than required for driving, using better efficiency areas of engine map
- **Charging of battery in vehicle standstill**: generator-mode



Hybrid powertrain – main operating modes



Following typical hybrid need to be realized by the hybrid control system:

- **Start / Stop Strategy**: engine shut-off of when vehicle is stalled and immediate ice start when touching throttle pedal
- **Recuperation**: recovery of braking energy by generator mode of the e-motor, charging of tractions battery while motoring the vehicle
- **„Boosting“**: short time adding of electric motor and ice torque for acceleration
- **Load shifting of ic-engine** : charging battery during driving by ic-engine (higher torque demand than required for driving, using better efficiency areas of engine map)
- **Charging of battery in vehicle standstill**: generator-mode



Hybrid powertrain – Start/Stop operating mode



Start / Stop Strategy

The following considerations refer especially to the ice start procedure in a hybrid vehicle

- The engine shut-off when vehicle is stalled and immediate ice start when touching throttle pedal can be done more efficiently and more comfortably with hybrids
- ICE start can be strategically planned in advance allowing “preheating” of engine (coolant water by latent heat storage system or thermos jug) or electric preheating of catalyst system
- Intermittent operation – cost (fuel cons.), electric energy for a start procedure ?
- Intermittent operation – boundaries from aftertreatment system:
 - emission effect (?) > HC peaks?
 - cooling effect of start procedure on catalyst
 - light off temperature of catalyst
 - strategies/devices keeping catalyst hot
- Reliability/life time of engines might be reduced



Operation Mode – Start/Stop

Minimizing ICE Operation Periods

- *Depending on driving schedule ICE can be switched off (need-based)*
- *Hybridization brings potential for Optimization of emissions and fuel consumption for start*
- *Quicker and better “comfort start” with hybridization*

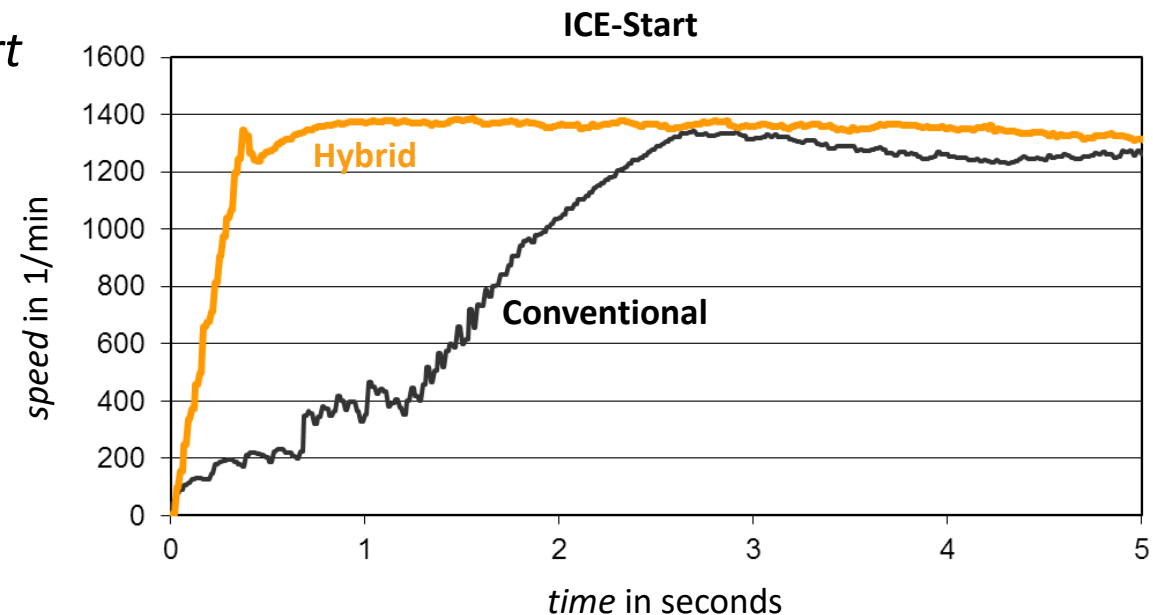

Operation Mode – Start Torque

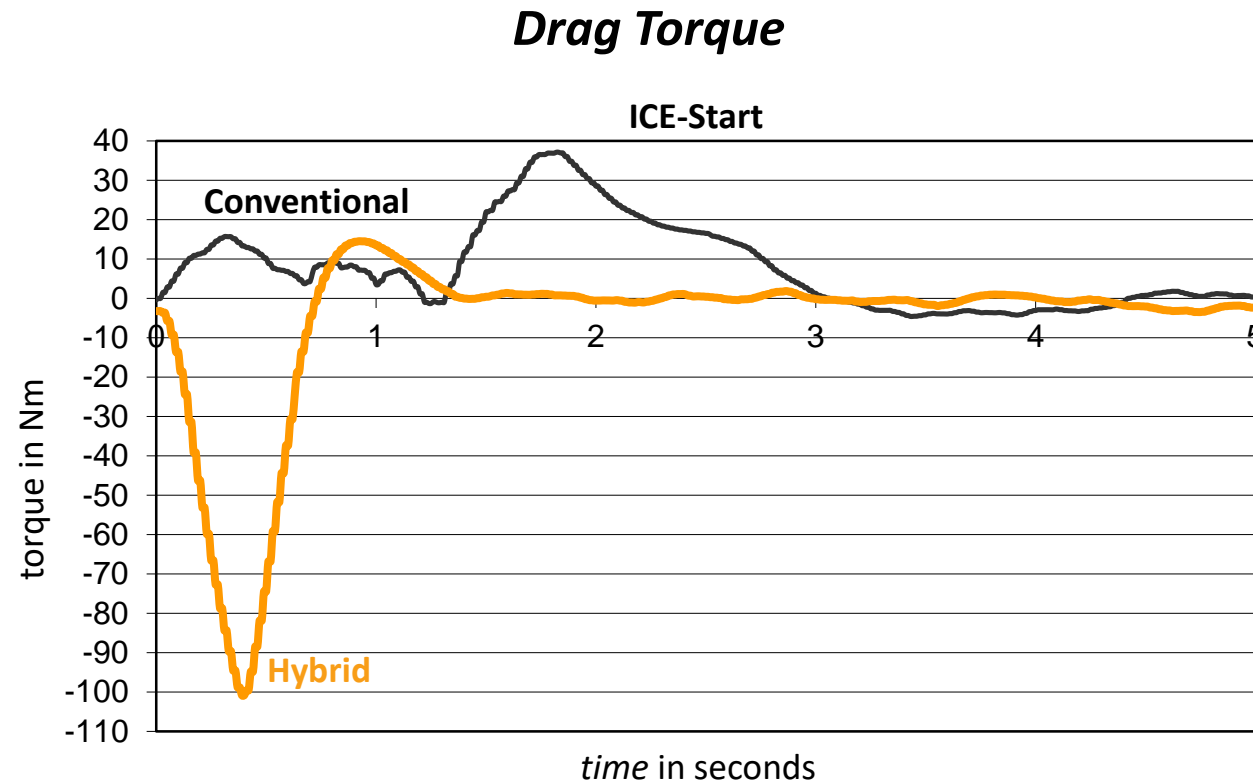

Operation Mode – Start Emission

Hydrocarbons HC

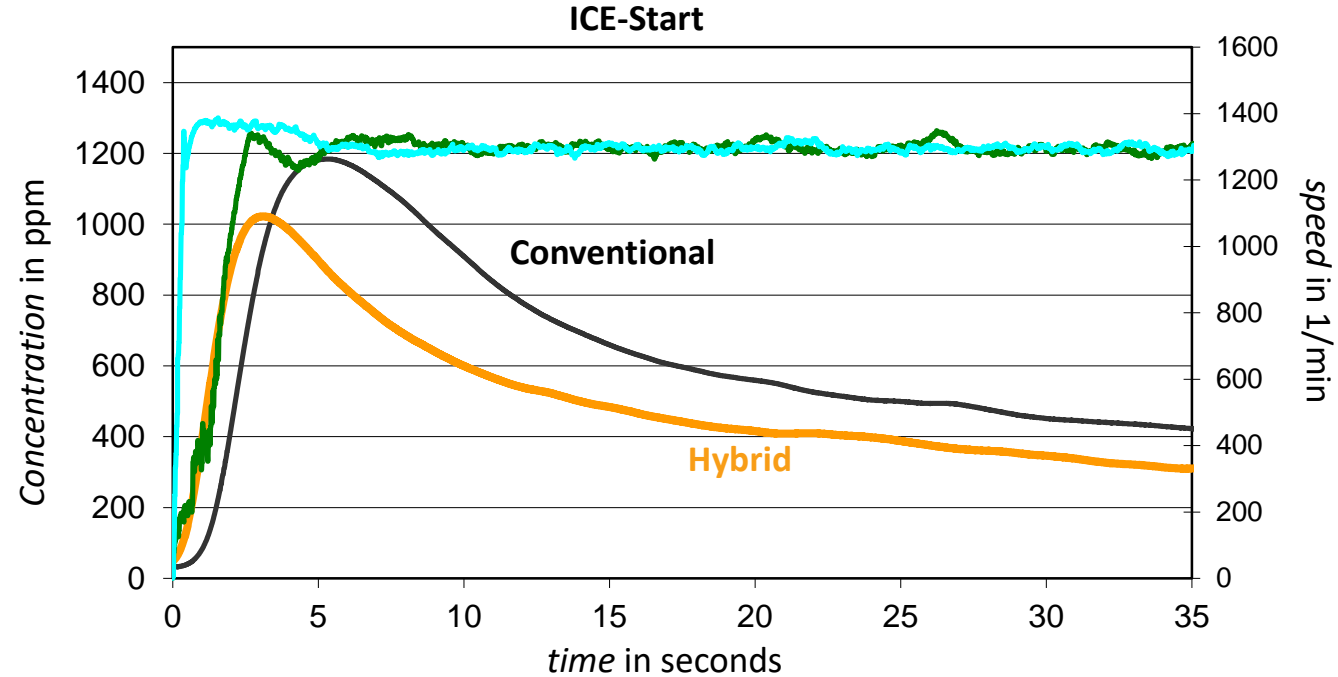

Winter, Stefan: Simulationsgestützte Optimierung eines Parallelhybridantriebsstrangs durch methodische Adaptierung eines modernen direkteinspritzenden aufgeladenen Ottomotors. Wien (2008), Dissertation TU Wien

Hybrid powertrain – main operating modes



Following typical hybrid need to be realized by the hybrid control system:

- **Start / Stop Strategy**: engine shut-off of when vehicle is stalled and immediate ice start when touching throttle pedal
- **Recuperation**: recovery of braking energy by generator mode of the e-motor, charging of tractions battery while motoring the vehicle
- **„Boosting“**: short time adding of electric motor and ice torque for acceleration
- **Load shifting of ic-engine** : charging battery during driving by ic-engine (higher torque demand than required for driving, using better efficiency areas of engine map)
- **Charging of battery in vehicle standstill**: generator-mode



Hybrid powertrain – Recuperation of brake energy



Brake Energy Recuperation

The following consideration refer especially to the recuperation of brake energy in a hybrid vehicle

- In principle same consideration apply as discussed with EVs
- Additionally ice engine friction torque need to be considered in certain circumstances



Operation Mode – Recuperation of brake energy

Fuel Consumption for Vehicles with Regenerative Braking

$$\tilde{\eta}_b \equiv \frac{E_{b,TR}}{H_f \cdot m_{f,TR}}$$

$$\tilde{\eta}_{dr} \equiv \frac{(E_{TR} - \xi \cdot E_{BR})}{E_{b,TR}}$$

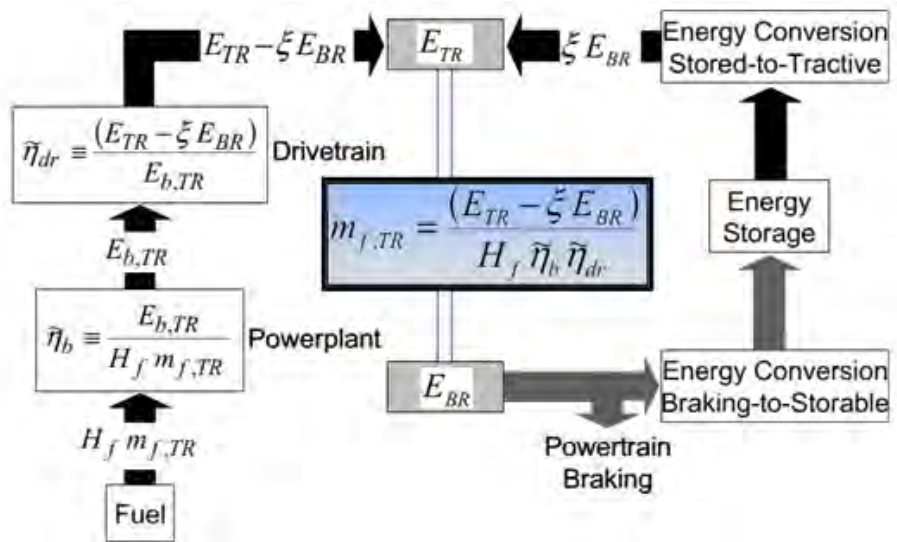

- $\tilde{\eta}_b$... fuel – consumption – weighted average brake thermal efficiency for a hybrid vehicle during powered driving
- $E_{b,TR}$... total engine brake energy delivered to the drivetrain for propulsion in kJ
- $\tilde{\eta}_{dr}$... energy – transfer – weighted average drivetrain efficiency for a hybrid vehicle during powered driving
- E_{TR} ... total tractive energy required at the tire–road interface for a hybrid vehicle during powered driving in kJ
- ξ ... braking–wheel to traction–wheel regeneration effectiveness
- E_{BR} ... total energy removed by wheel braking in kJ

Hybrid powertrain – main operating modes



Following typical hybrid need to be realized by the hybrid control system:

- **Start / Stop Strategy**: engine shut-off of when vehicle is stalled and immediate ice start when touching throttle pedal
- **Recuperation**: recovery of braking energy by generator mode of the e-motor, charging of tractions battery while motoring the vehicle
- **„Boosting“**: short time adding of electric motor and ice torque for acceleration
- **Load shifting of ic-engine** : charging battery during driving by ic-engine (higher torque demand than required for driving, using better efficiency areas of engine map)
- **Charging of battery in vehicle standstill**: generator-mode

Hybrid powertrain – Boosting mode



ICE Boosting

The following considerations refer especially to the power boosting in a hybrid vehicle

- Adding torque for high power demand situations like vehicle launch, overtaking.
- Some potential to avoid ICE full load conditions > avoid map areas $\lambda < 1$ and worse fuel consumption > better efficiency
- In general little/none possibility for fuel consumption reduction (long efficiency chain @ electric side!)



Hybrid powertrain – main operating modes



Following typical hybrid need to be realized by the hybrid control system:

- **Start / Stop Strategy**: engine shut-off of when vehicle is stalled and immediate ice start when touching throttle pedal
- **Recuperation**: recovery of braking energy by generator mode of the e-motor, charging of tractions battery while motoring the vehicle
- **„Boosting“**: short time adding of electric motor and ice torque for acceleration
- **Load shifting of ic-engine** : charging battery during driving by ic-engine (higher torque demand than required for driving, using better efficiency areas of engine map)
- **Charging of battery in vehicle standstill**: generator-mode



Hybrid powertrain – Load shifting mode



ICE Load Shifting “LPS”

The following considerations refer especially to the load shifting in a hybrid vehicle

- In the engine efficiency map or specific fuel consumption area operating points with good and bad efficiency can be identified – higher load points good, part load bad h!
- If electric energy need to be produced on board (not taken from the grid), electricity shall be produced in map areas where efficiency is high or “energy is cheap”!



Hybrid powertrain – Load shifting mode

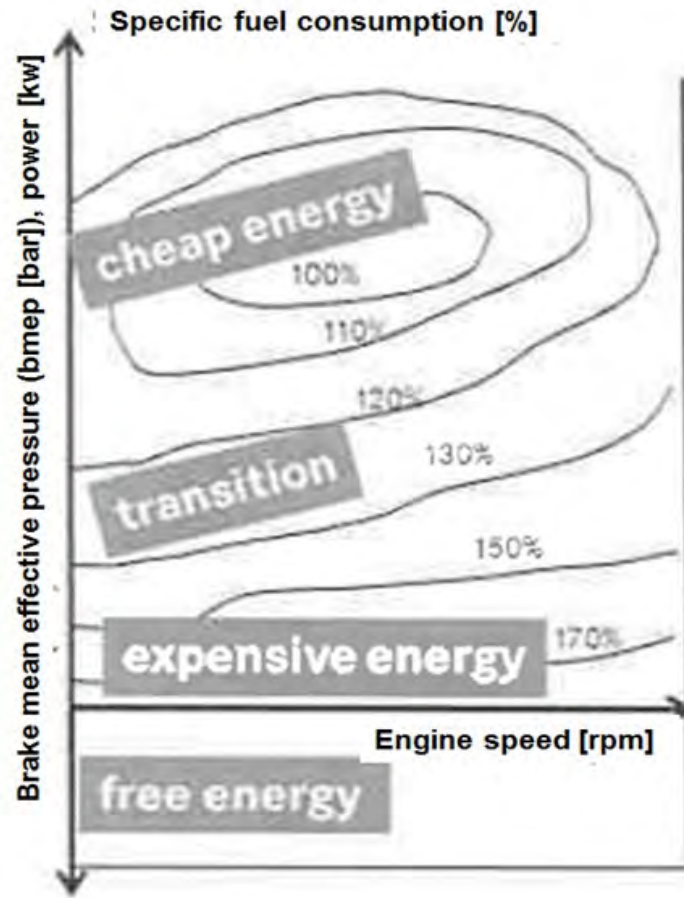

Cost of (electric) energy in the ICE map

- In general the energy management of advanced powertrains need to focus on areas where energy produced is cheap or even for free!
- Free energy > brake energy recovery
- Cheap energy for electricity production @ at higher loads to avoid inefficient engine map areas.
- Avoiding full load conditions
- The so produced energy will be stored in the battery for later use with a good total efficiency

Operation Mode - Load Point Shifting (LPS)

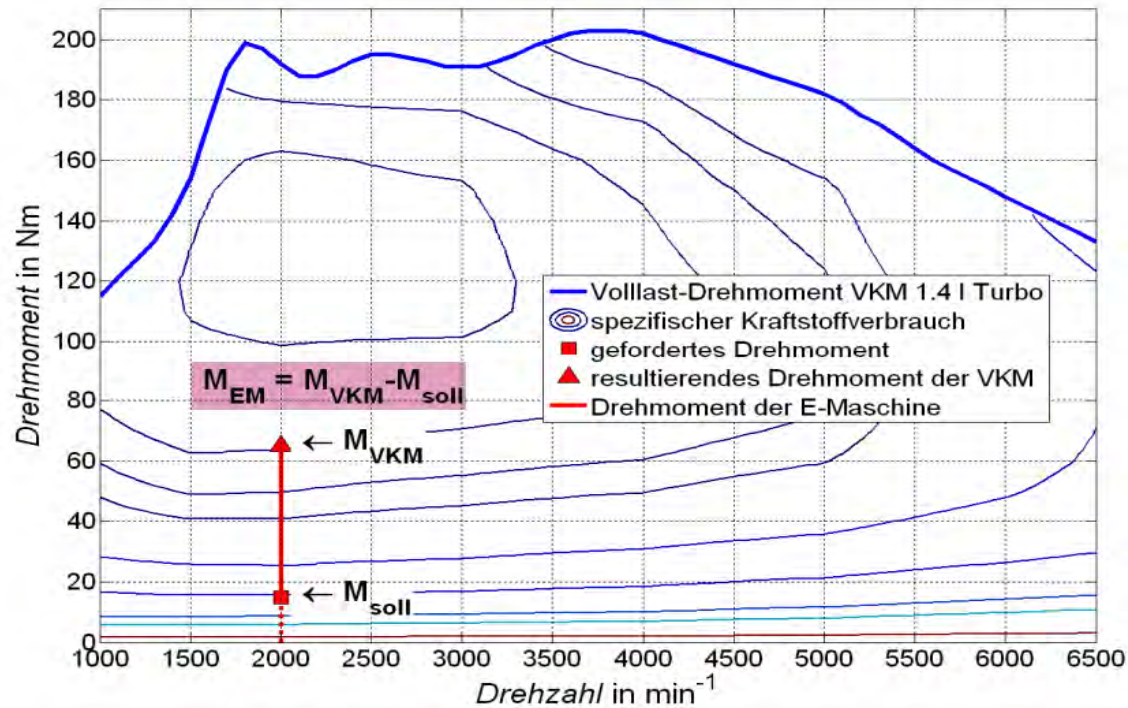

Load Point Shifting is defined by:

- Required Speed of ICE (n)
- Required Torque (M_{soll})
- Load Point Shifting Torque of Electric Machine (M_{EM})

$$be_{(LPA)}|_{n=konst} = \frac{BE_{(M_{VKM})}}{P_{soll} + P_{EM} \cdot \eta_{gen} \cdot \eta_{batein} \cdot \eta_{bataus} \cdot \eta_{mot}} \quad \text{in } g/kWh$$

Winter, Stefan: Simulationsgestützte Optimierung eines Parallelhybridantriebsstrangs durch methodische Adaptierung eines modernen direktinspritzenden aufgeladenen Ottomotors. Wien (2008), Dissertation TU Wien

Operation Mode - Load Point Shifting (LPS)

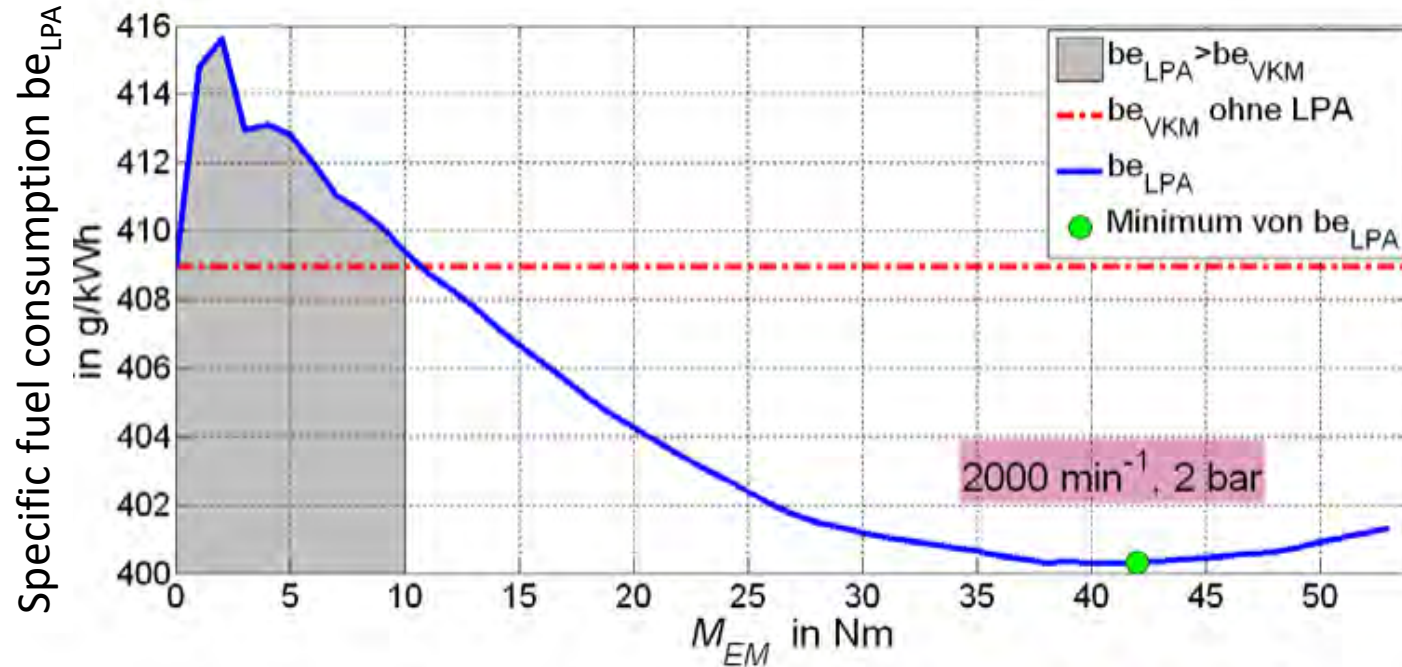

$be_{(LPA)}$ über LPA-Moment M_{EM} für LPA bei 2000 min^{-1} 2 bar

$$be_{(LPA)}|_{n=\text{konst}} = \frac{BE_{(M_{VKM})}}{P_{\text{soll}} + P_{EM} \cdot \eta_{\text{gen}} \cdot \eta_{\text{batein}} \cdot \eta_{\text{bataus}} \cdot \eta_{\text{mot}}} \quad \text{in g/kWh}$$

Operation Mode - Load Point Shifting (LPS)

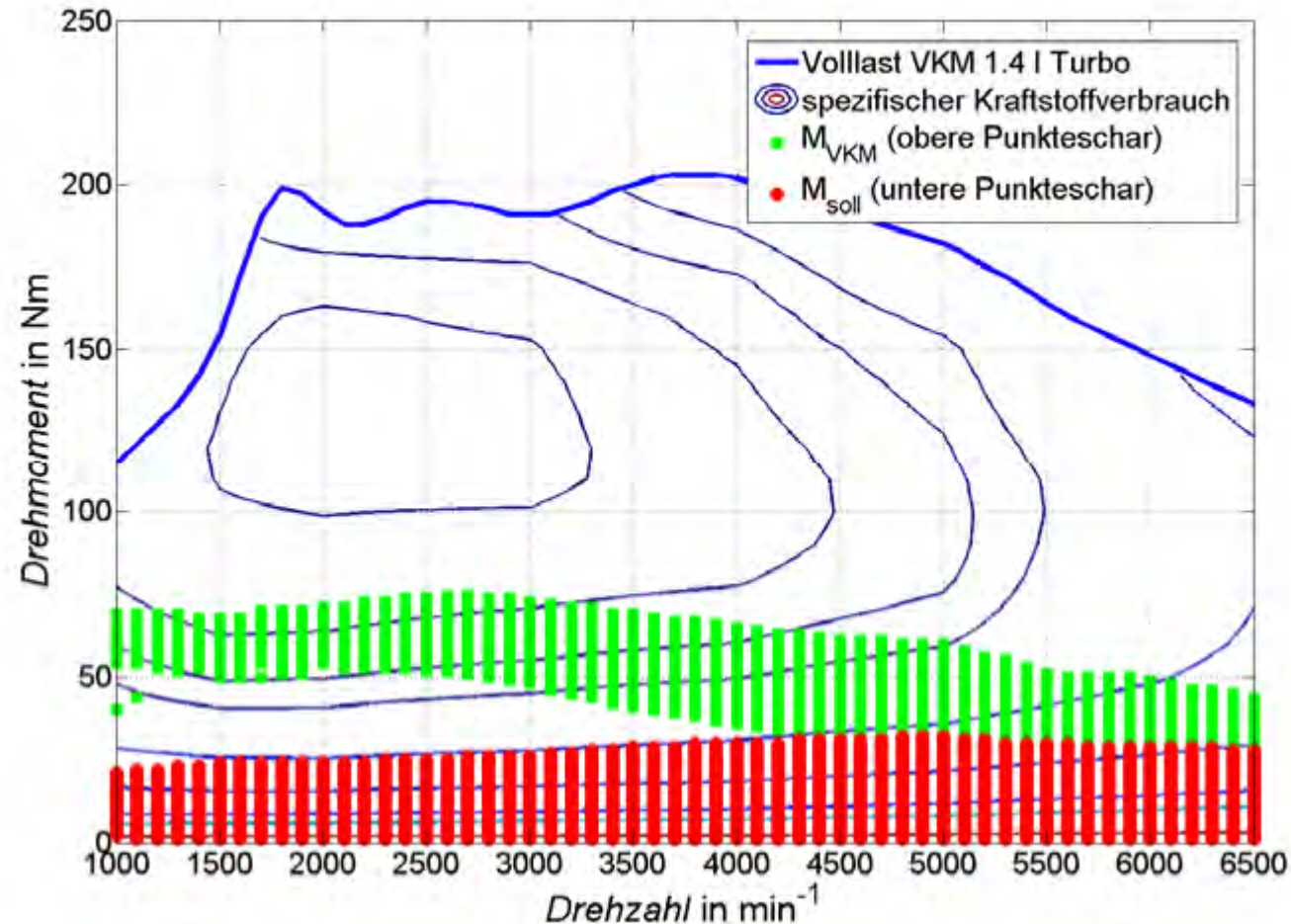

Winter, Stefan: Simulationsgestützte Optimierung eines Parallelhybridantriebsstrangs durch methodische Adaptierung eines modernen direkteinspritzenden aufgeladenen Ottomotors. Wien (2008), Dissertation TU Wien

Downsizing & Downspeeding (CVT-)Operating strategy of Prius - ICE

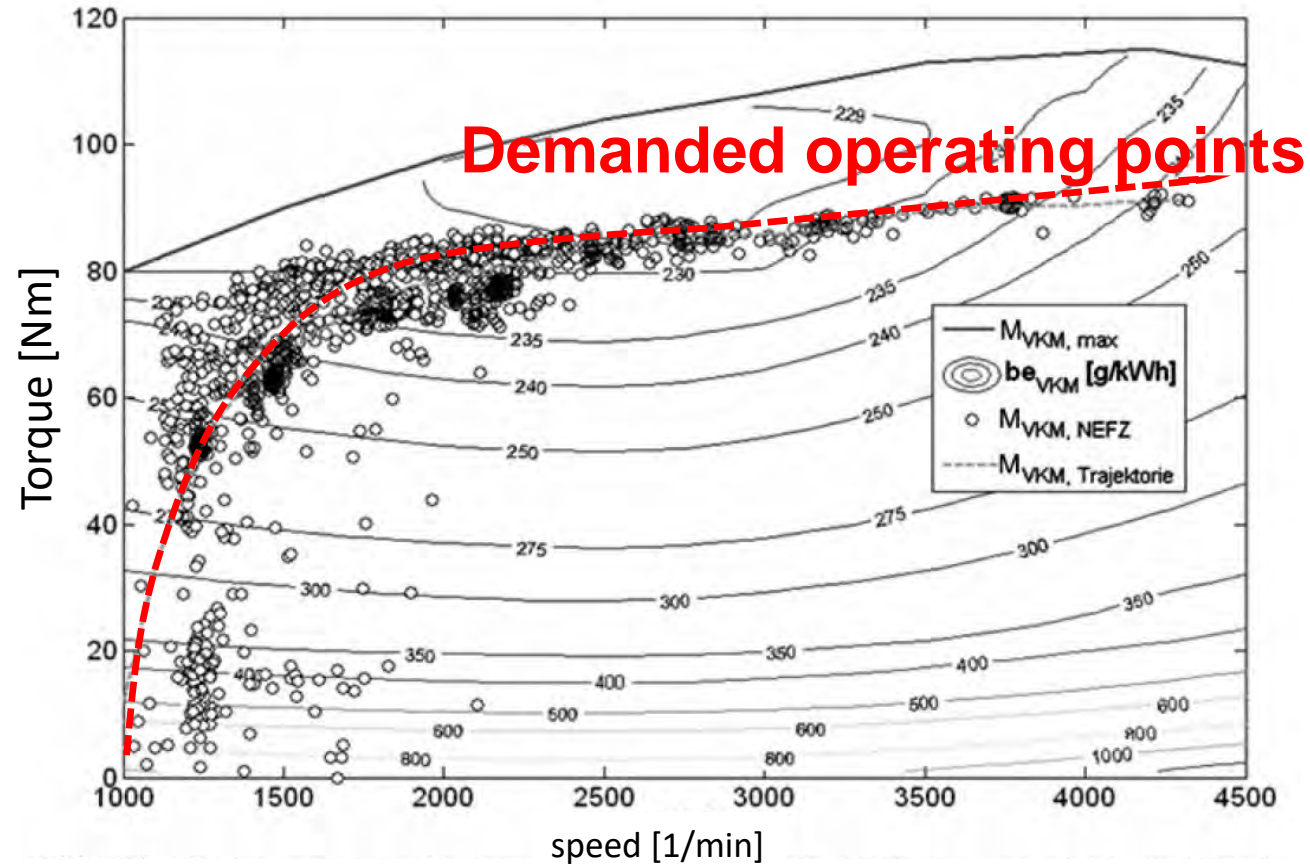

Operating Points of Prius ice in the city cycle and trajectory

Hybrid thermal management

- **Up to three cooling circuits @ 3 temperature levels are required in a hybrid car:** 90-110°C for the ice; 60-90°C for inverter and electric motor, 30 to 40°C for the battery; this complex system is an additional cost driver!
- **Additional heat can be generated by PTC heater or storage systems:** PTC heater reduces range, storage systems are also complex and expensive!
- **Electric driven A/C compressors:** standard solution, but requires high power (up to 3kW) and reduces pure electric range dramatically
- **Latent heat storage systems:** have not found their way into series production due to cost reasons
- Some hope to reduce effort can be expected by the introduction of new semiconductors (SiC), which allow higher cooling temperature for inverter



Measured results with EV and hybrids

■ Start / Stop Strategy:

Shut-off ICE - Intermittent engine operation

ICE is shut off in phases with bad efficiency and whenever not really needed (idle, part load operation,..). Re-start dependent on efficiency, dynamic requirement, SOC of battery. Comfort issues need to be observed.

EUROPEAN UNION

DRIVING CYCLE FOR EUROPEAN UNION
Urban ("ECE") + extra-urban cycle ("EUDC")

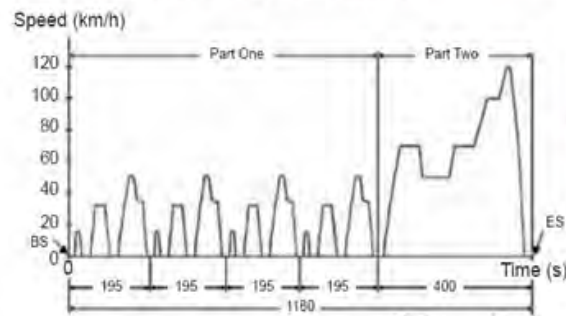

Potential savings: 5 to 12 %

Potentials for Savings in NEDC Cycle

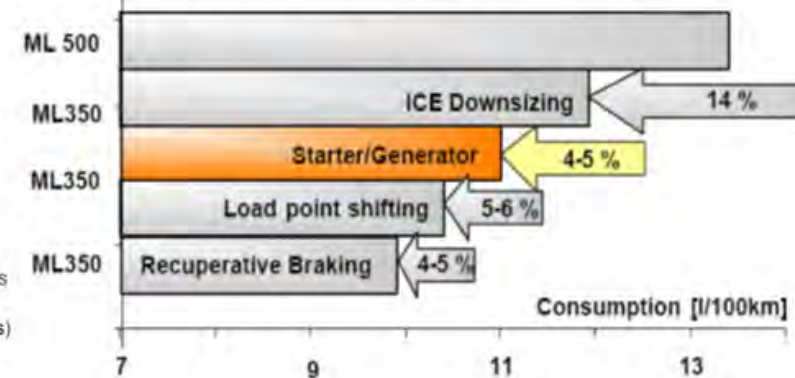

Fuel consumption with hybrid vehicles depending on operating strategies

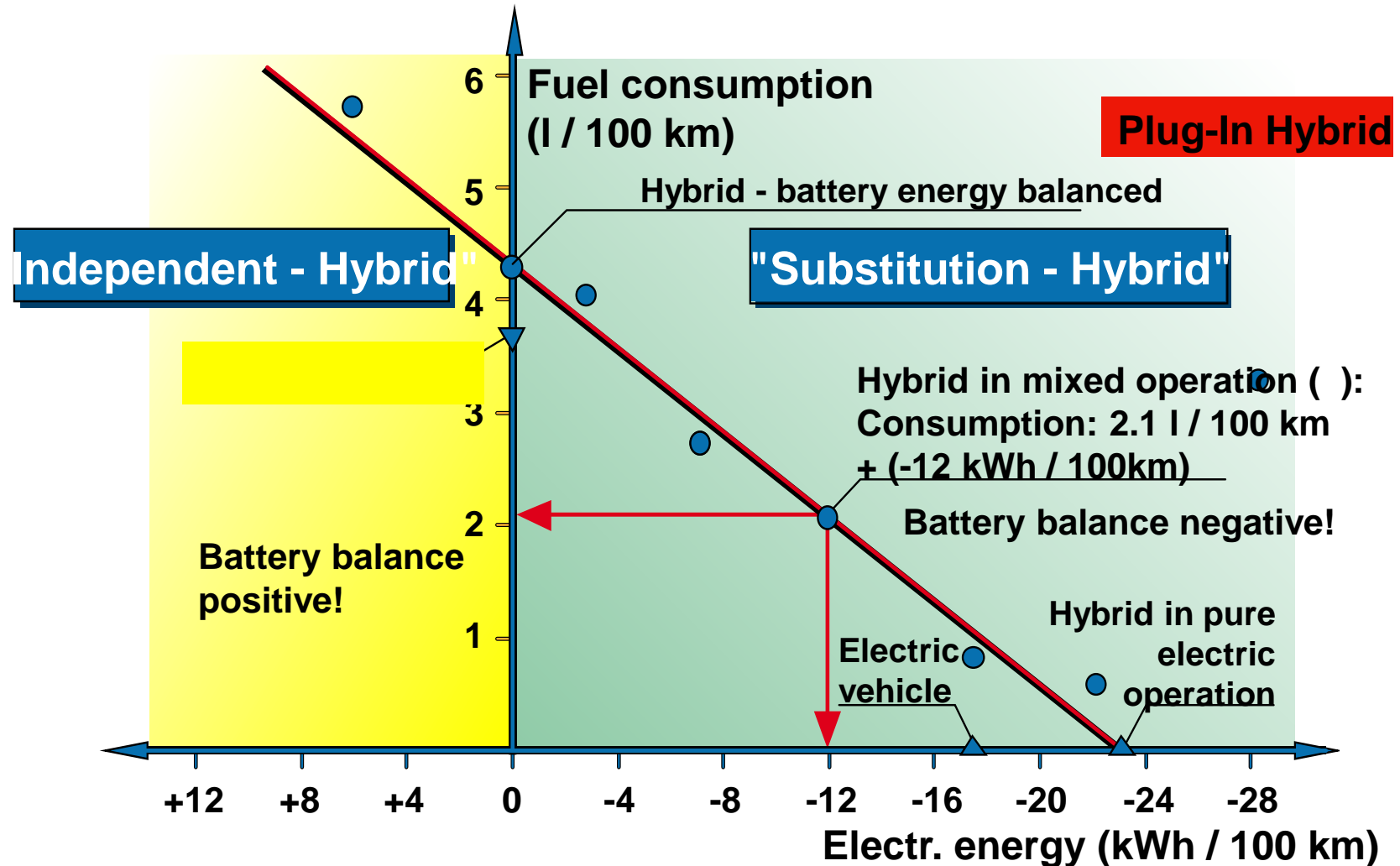

Energy Storage / Battery

- How far can I get with what kind of battery ?

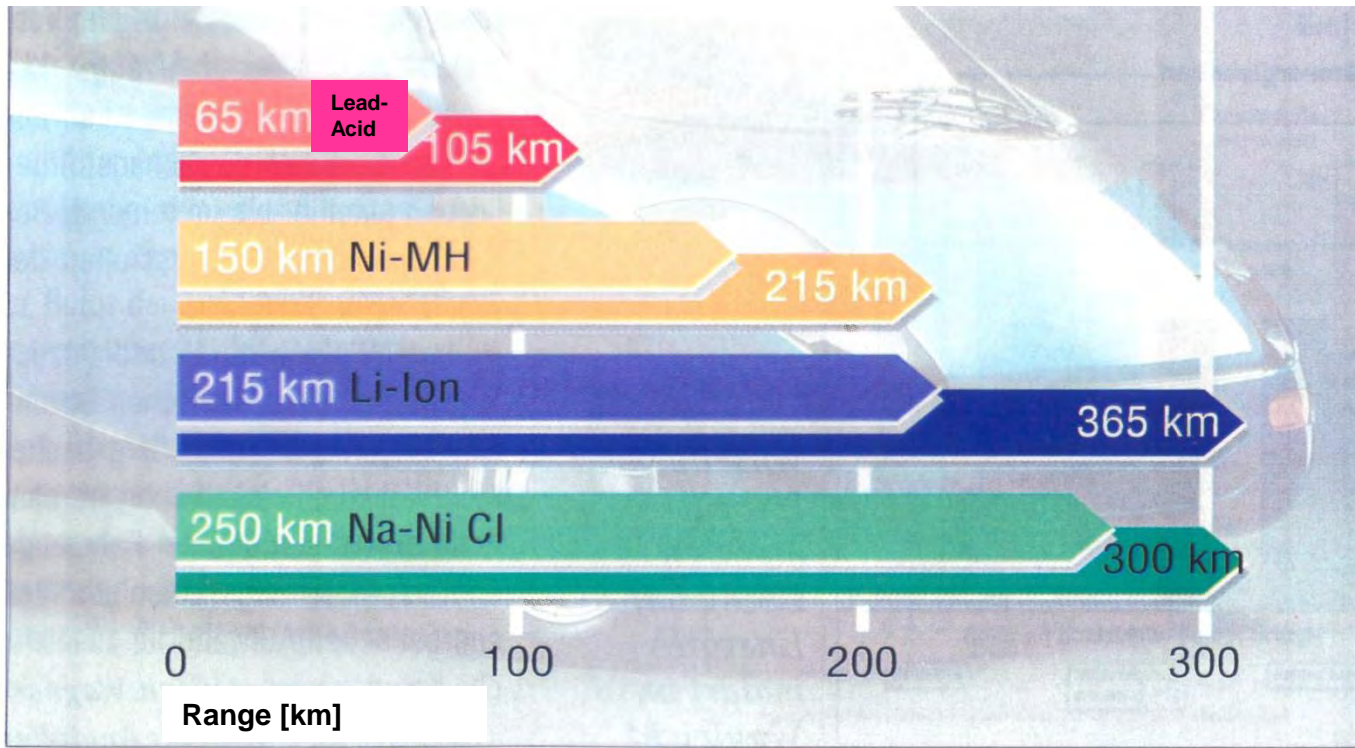

The expected improvements in battery technology in the last 10 years led to an abrupt increase in range [km]

Energy Storage Systems - Classification

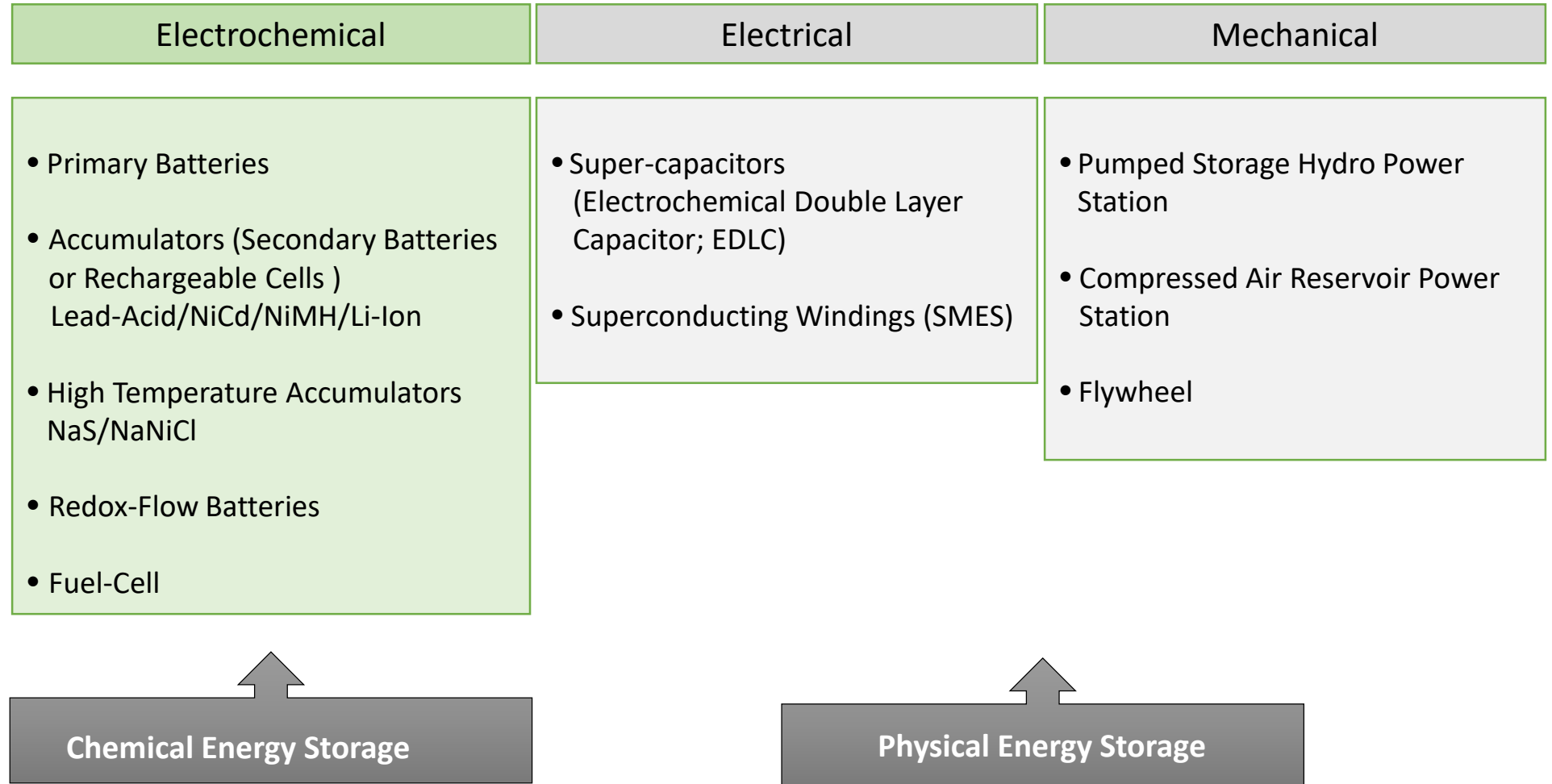

Chemical energy storages

Battery
 Primary and secondary types
 Energy storage in electrode material
 Static electrolyte in the cell

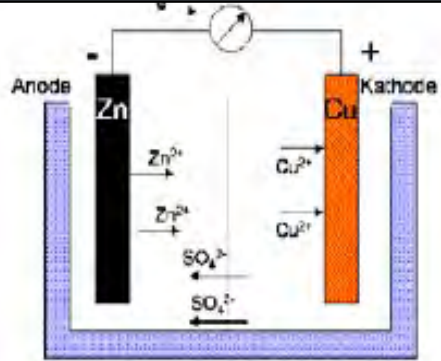

Flow battery
 Energy storage medium is Electrolyte stored in an external tank
 Hybrid between Fuel cell and battery

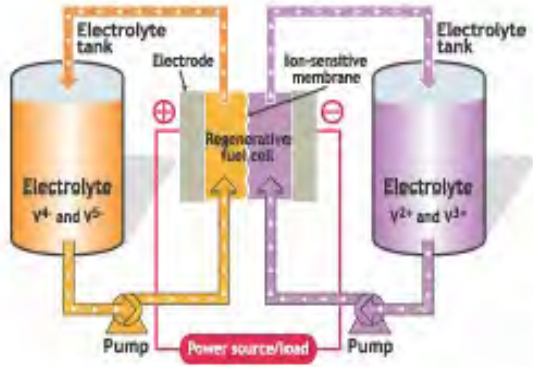

Fuel cell
 Energy medium is liquid or gaseous fuel
 Static electrolyte in the cell

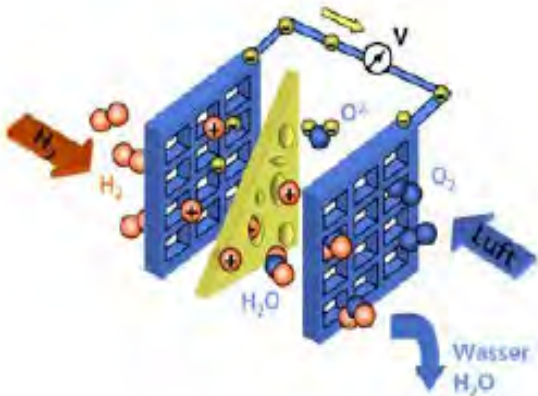

Super Capacitor
 Energy storage in electrical double layer, static electrolyte in the cell

Battery types: Ragone Diagramm

High specific energy and power

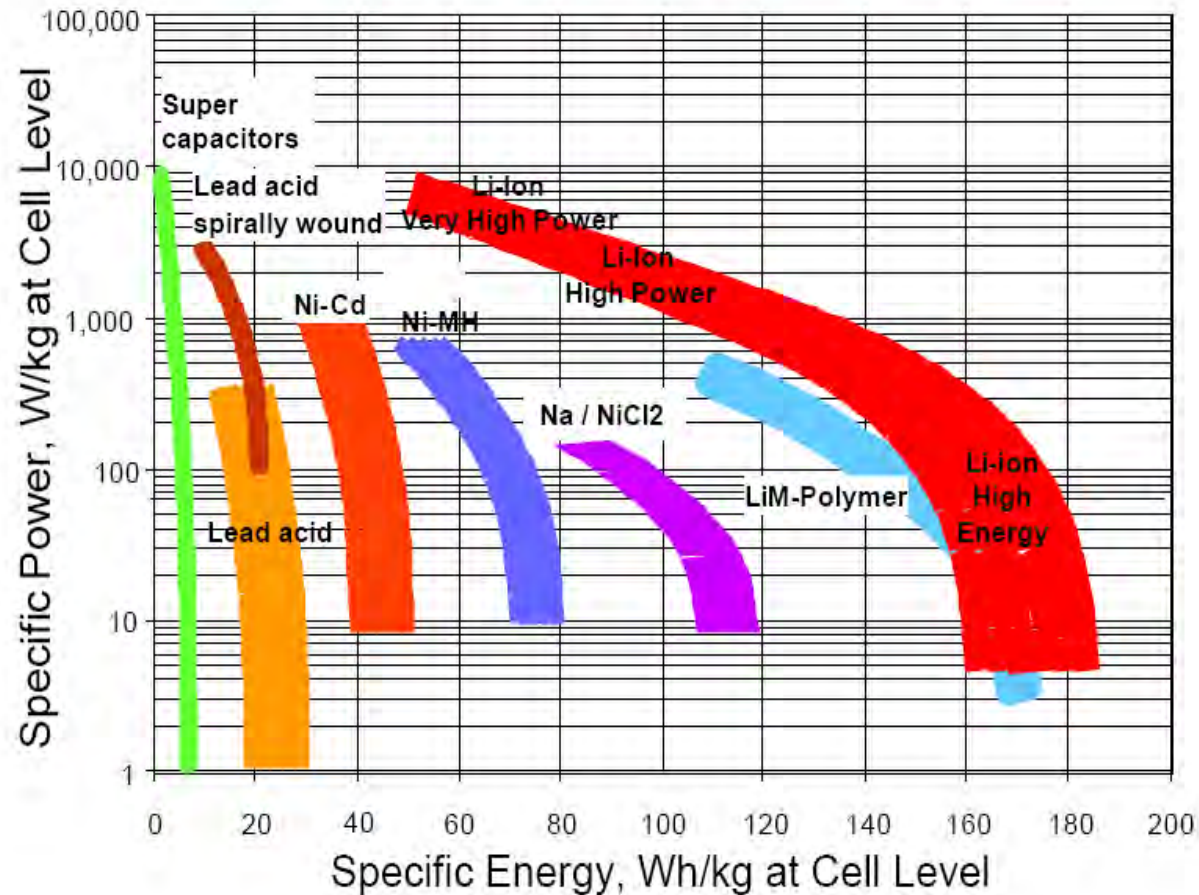

Source: JCS

Current Standard Li-Ionen Battery

Highest energy density !!!

But this technology requires extensive diagnosis!

Voltage limits for different cells
Too high or too low will destroy cell

Akkutechnologie	Unterspannung	Überspannung
LiFePO ₄	2,000V	3,800V
Lithium-Polymer	2,500V	4,250V

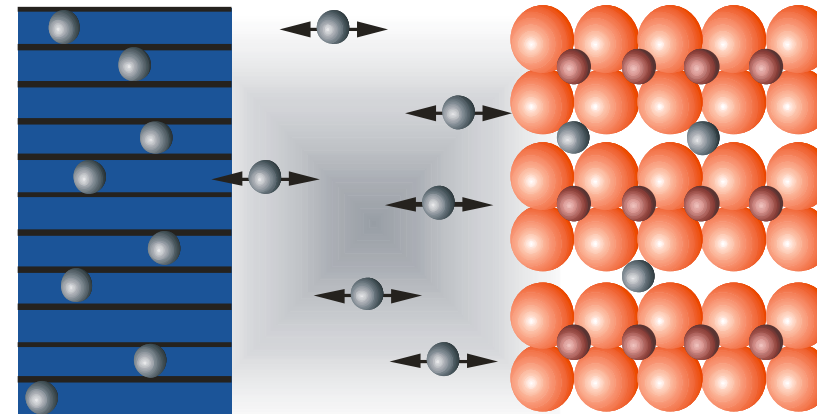

Negative Electrode Electrolyte Positive Electrode



Materials Inside a Lithium-Ion cell 1

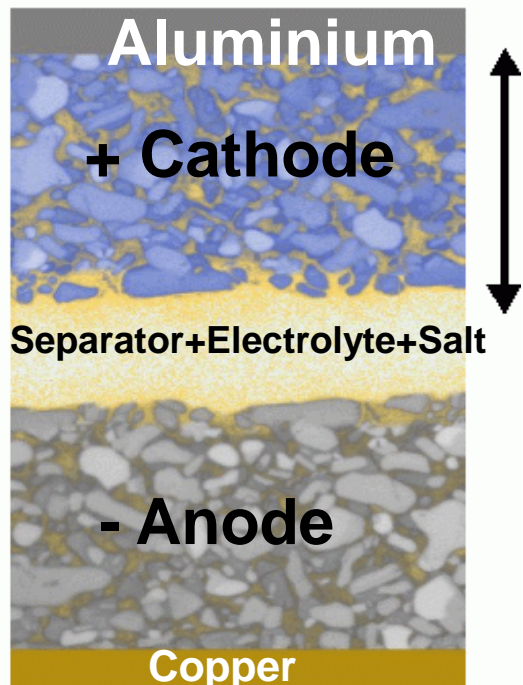

Materials found in commercially available Li-Ion cells:

Anode: Carbon (natural graphite, treated „hard“ carbon...)

Cathode: Lithium Metal Oxides (LiMn_2O_4 ,
 $\text{LiNi}_x\text{Mn}_y\text{Co}_z\text{O}_2$, LiCoO_2 , ...)
 Lithium Iron Phosphate (LiFePO_4)

Separator: Polymer (polyethylene-foil)

Electrolyte: Organic solvents (Ethyl carbonate, Diethyl Carbonate, Dimethyl Carbonate ...)

Conductive Salts: Lithium Hexafluorophosphate (LiPF_6)

Other Materials: Housing case (Al, stainless steel), laminated Al-foil

Lilon - Characteristics of different materials



Example :

Evaluation of different electrode materials

Material	Potential mV vs. Li/Li*	mAh/g	Safety	Stability	Cost
Graphite	10 - 300	320	0	+	+
Hard carbon	10 - 1000	200	+	+	+
Lithium alloy	50 - 800	< 3900 Si < 1000 Sn	0	-	?
$\text{Li}_4\text{Ti}_5\text{O}_{12}$	1400 - 1600	150	++	++	0

Anode material

Material	Energy density	Power density	Safety	Stability	Cost
LiCoO_2	Yellow	Orange	Orange	Green	Red
$\text{LiNi}_{0.8}\text{Co}_{0.15}\text{Al}_{0.05}\text{O}_2$	Green	Green	Red	Green	Yellow
$\text{LiNi}_{1/3}\text{Co}_{1/3}\text{Mn}_{1/3}\text{O}_2$	Yellow	Yellow	Orange	Green	Yellow
LiMn_2O_4	Red	Green	Yellow	Red	Green
LiFePO_4	Red	Green	Green	Green	Green

Cathode material

Evaluation regarding:

- energy density
- safety,
- stability (aging)
- costs



Co-funded by the Erasmus+ Programme of the European Union

Li-Ion – Cell development / Status

- Currently:
Lithium-Ionen Batteries 2. Generation

- liquid electrolyt
- high Cobalt content

- Future:

- Reduction Cobalt content
- Silicium content increase
- **OCV up to 4.4 V**
- **Solid state-Electrolyte**
(leak proof and fire safe)
- **Metal-Air-Electrodes (Li/O₂)**

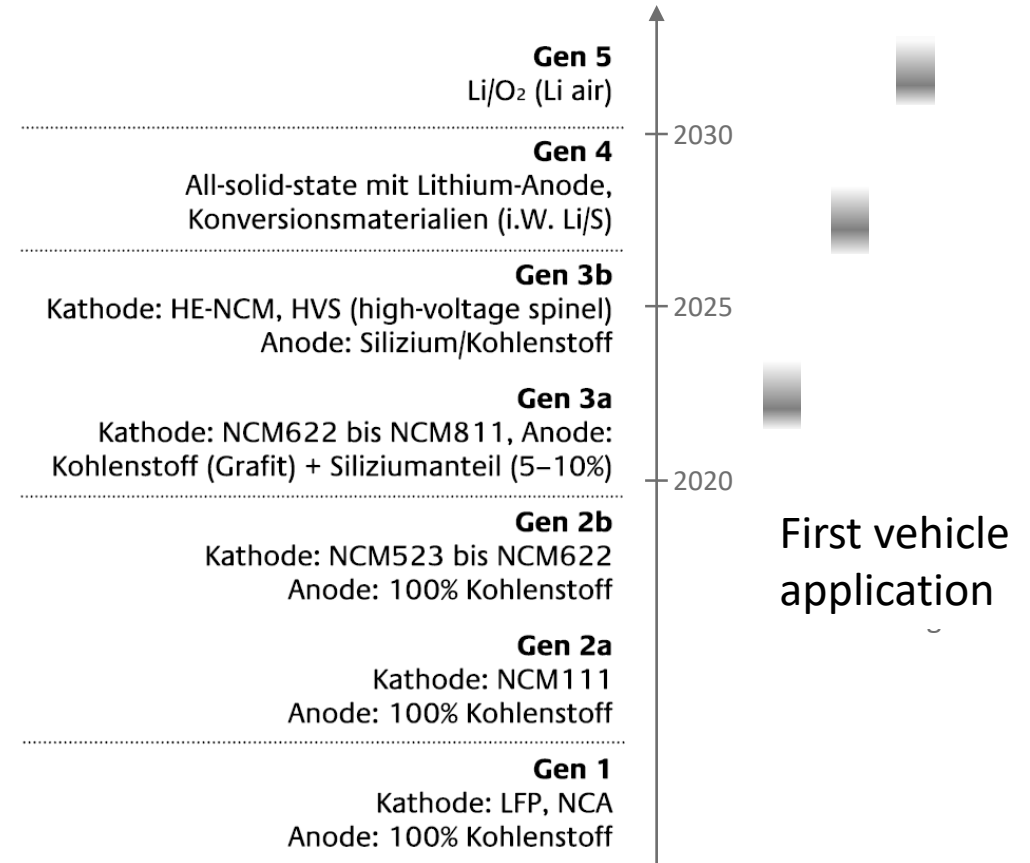

Quelle: NPE, 2016



Battery Key-Performance Parameter

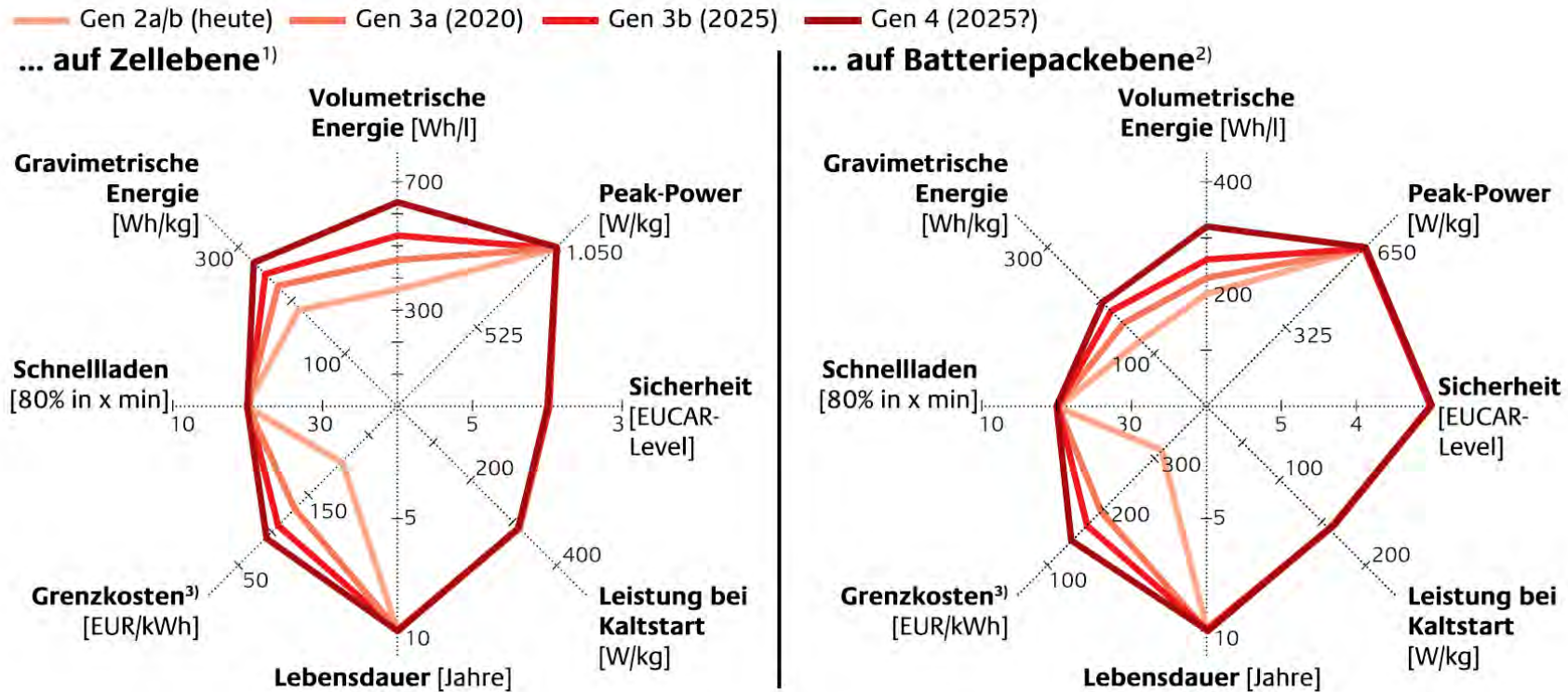

1) Batterie zelle für EV 2) Batterie pack für EV mit 80 kWh 3) Bei 15 Mio. Zellen über Lebenszyklus eines Fahrzeugs oder einer Fahrzeugfamilie (entspricht heute bei Gen 2a ~70k Fahrzeuge mit 20 kWh Energieinhalt)
 Quelle: NPE UAG 2.2 M. Weiss, A. Lamm, P. Lamp (2015)

Which electrode chemistry for which application?

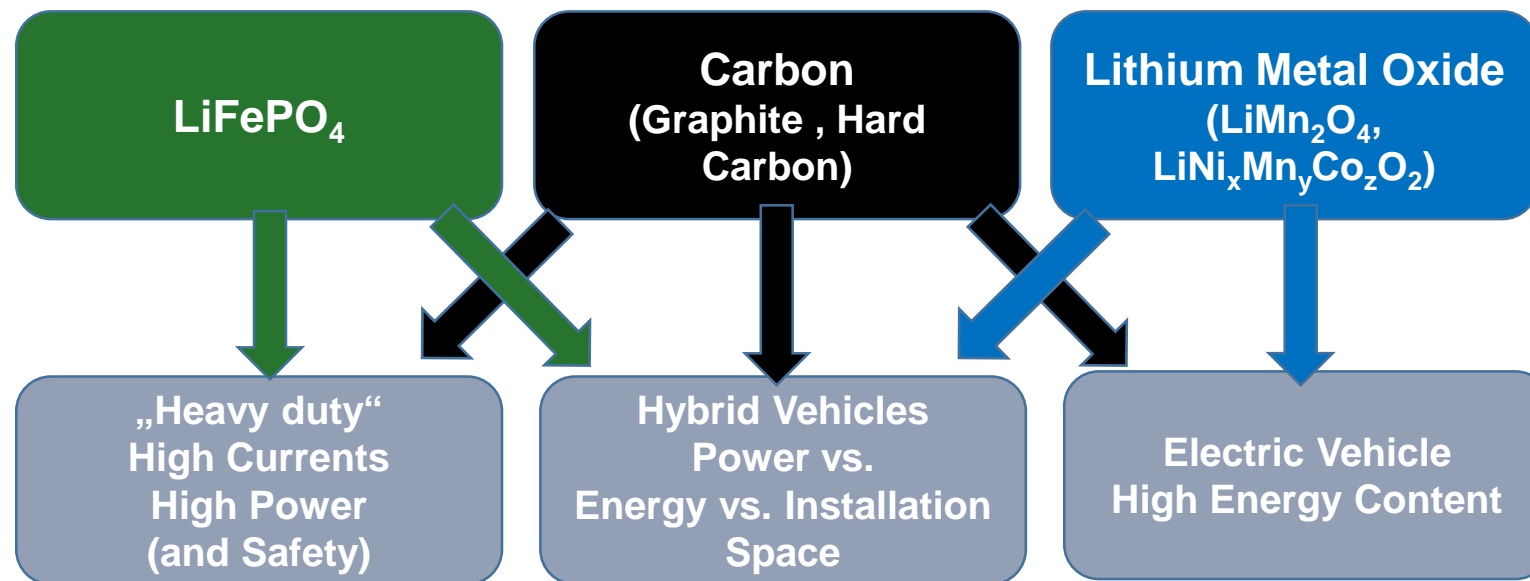

Battery selection & dimensioning

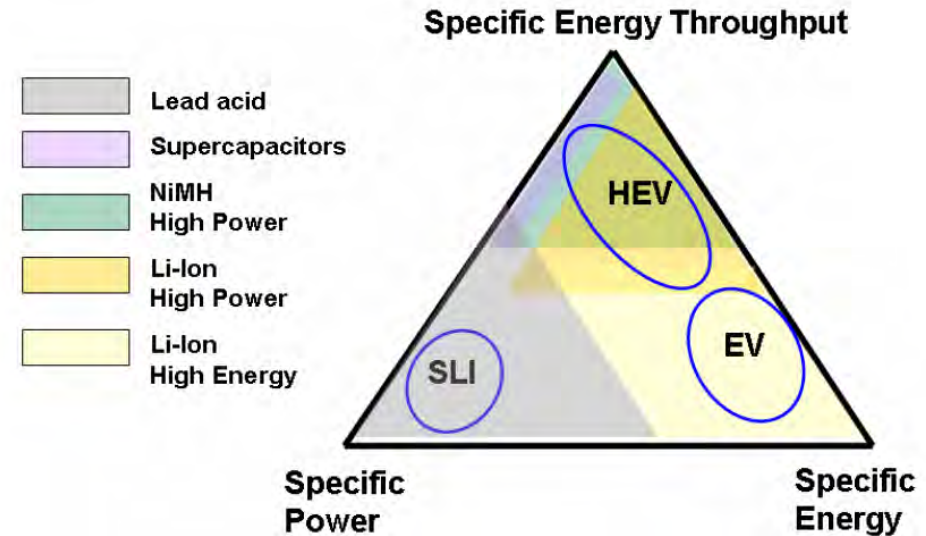
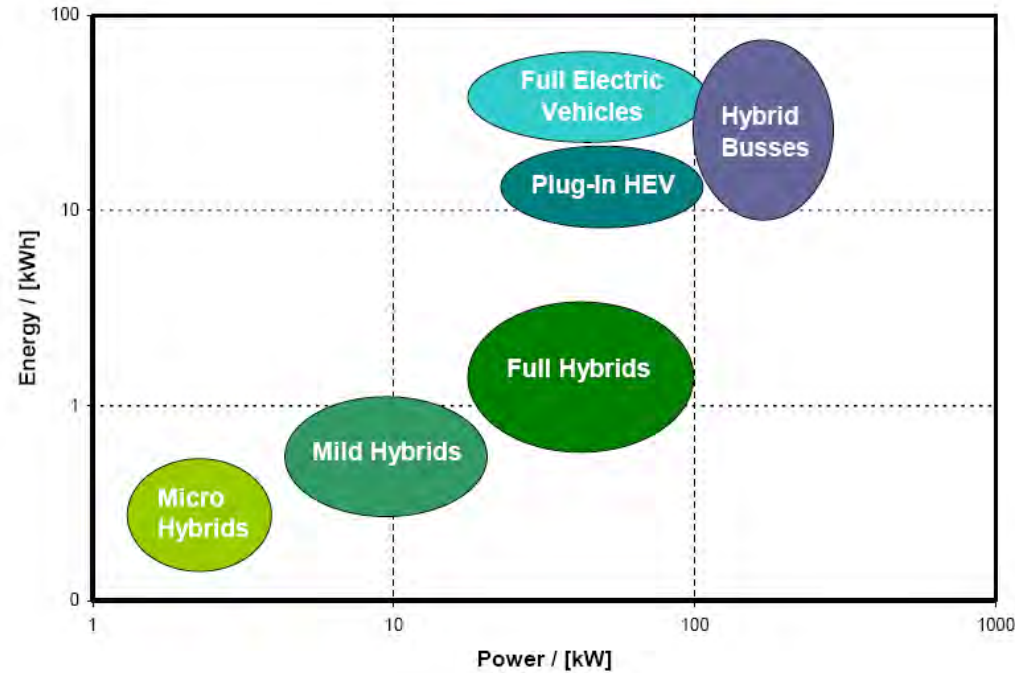

The challenge is to select the correct:

- ✓ cell technology (chemistry)
- ✓ cell size and
- ✓ cell design!



Cell Characteristics for the 3 Automotive Applications

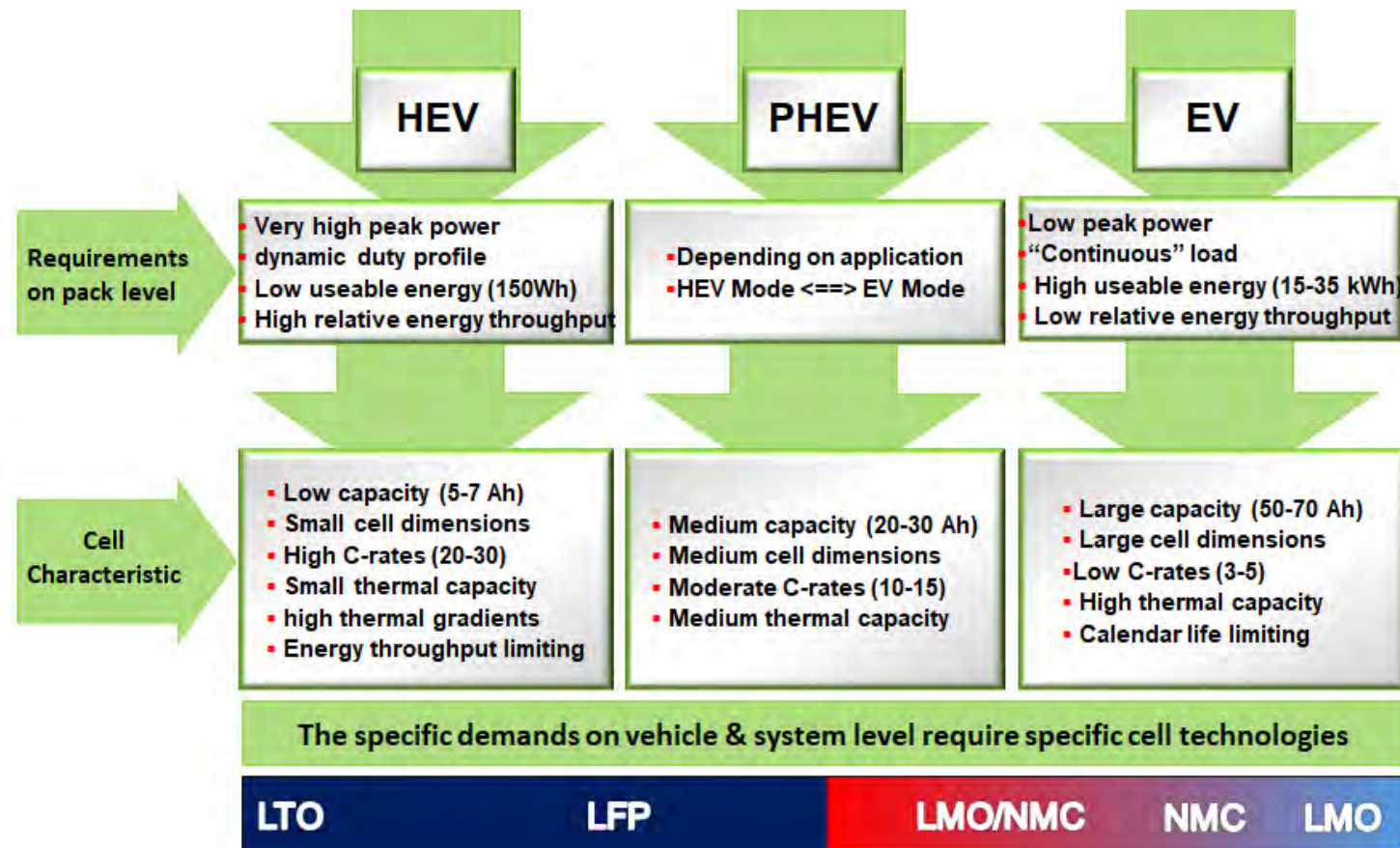

Future Technologies

Comparison of several Lithium-Battery combinations

Lithium-Battery Combination	Theoretical Specific Energy [Wh/kg]	Theoretical Specific Capacity [Ah/kg active material]
Li / $\text{Li}_x\text{Mn}_2\text{O}_4$	428	285
LiC_6 / Li_xCoO_2	570	273
Li / $\text{Li}_x\text{V}_6\text{O}_{13}$	890	412
Li / Li_xTiS_2	480	225
Li-S	2600 (complete reaction to Li_2S)	1672
Li-Air	5200 (with O_2 mass) 11140 (without O_2 mass)	>2500



Lithium-Sulfur Cell

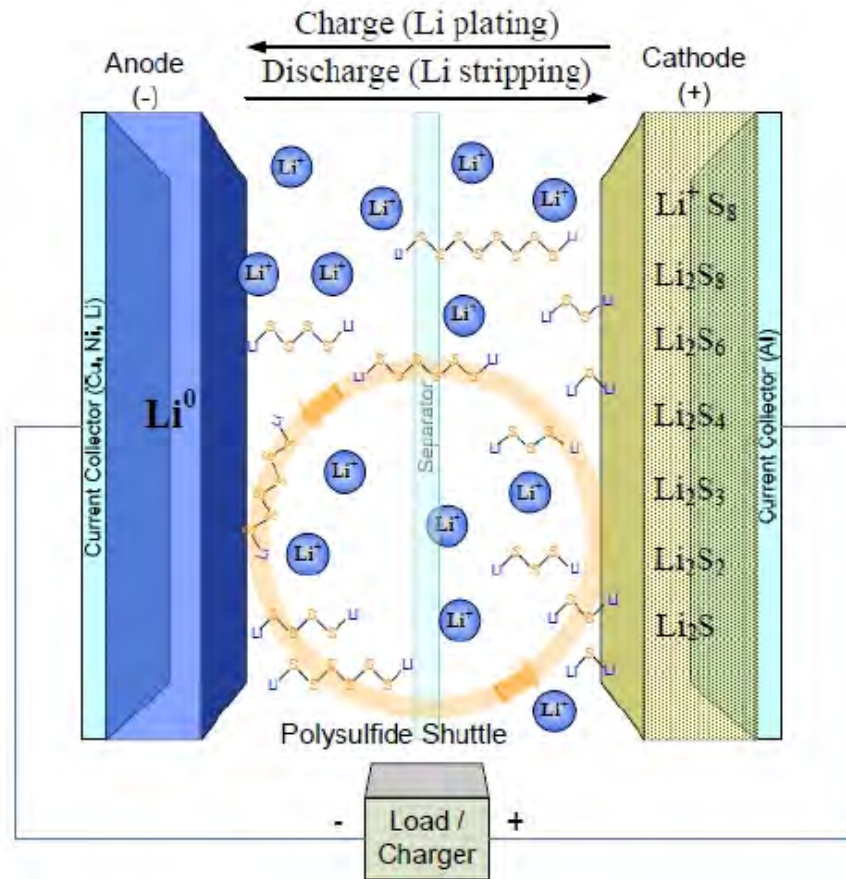

Advantages:

- ✓ High theoretical specific capacity (1672 Ah/kg) and high specific energy (2600 Wh/kg)
- ✓ Low material costs and high availability of sulfur
- ✓ Environmentally friendly materials (non-toxic)
- ✓ Intrinsic protection against overload

State of Development → Sion Power (collaboration with BASF):

- Capacity: 2,4 – 2,8 Ah
- Voltage: 2,1 V
- Specific Energy: 350 – 380 Wh/kg
- Cycles? Temperature?

Expected launch date: 2020

Lithium-Air Cell

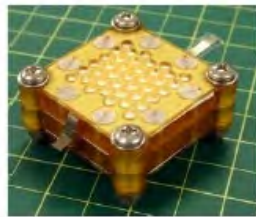
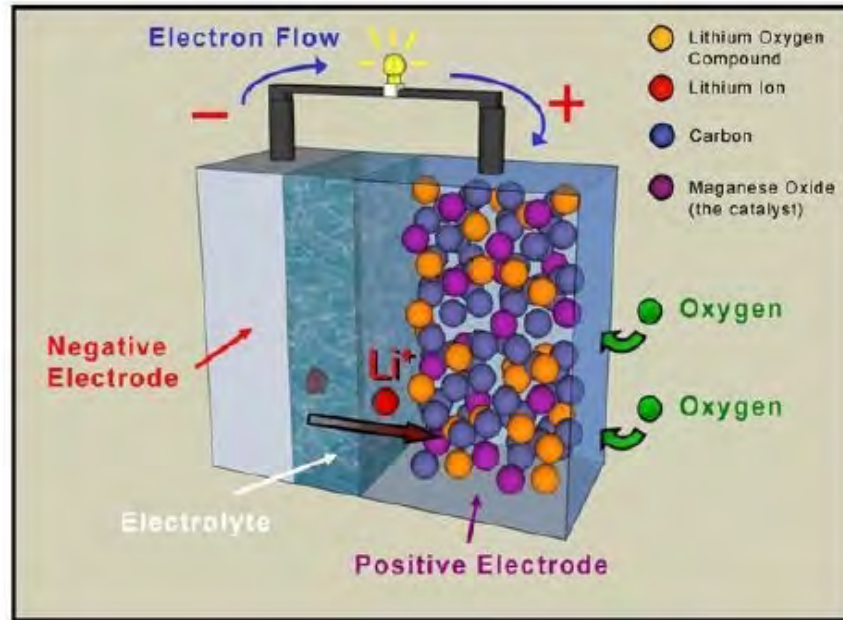

Li/air cell



coin-type Li/air cell

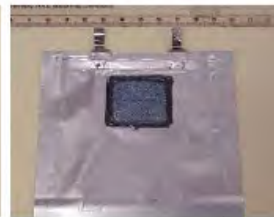

Li/air pouch cell

Advantages:

- ✓ Highest theoretical specific energy (11.140 Wh/kg, 5-10 times higher than Li-ion batteries)
- ✓ Cathodic reactant from the air → no need to be stored
- ✓ Compared to other systems: environmentally-friendly
- ✓ Higher safety compared to lithium-ion batteries (only one reactant in the system)
- ✓ Potential for high number of cycles and long shelf life



Expected launch date: 2030



Conclusion

Lithium-Air and Lithium-Sulfur Batteries



- Both technologies are limited in their cycle life (<100) and constitute insufficient capacity at high discharge rates
- At the present there's a high development potential within these areas
- Development horizon: 10 – 20 years



Hydrogen Storage Systems: Requirements and Challenges

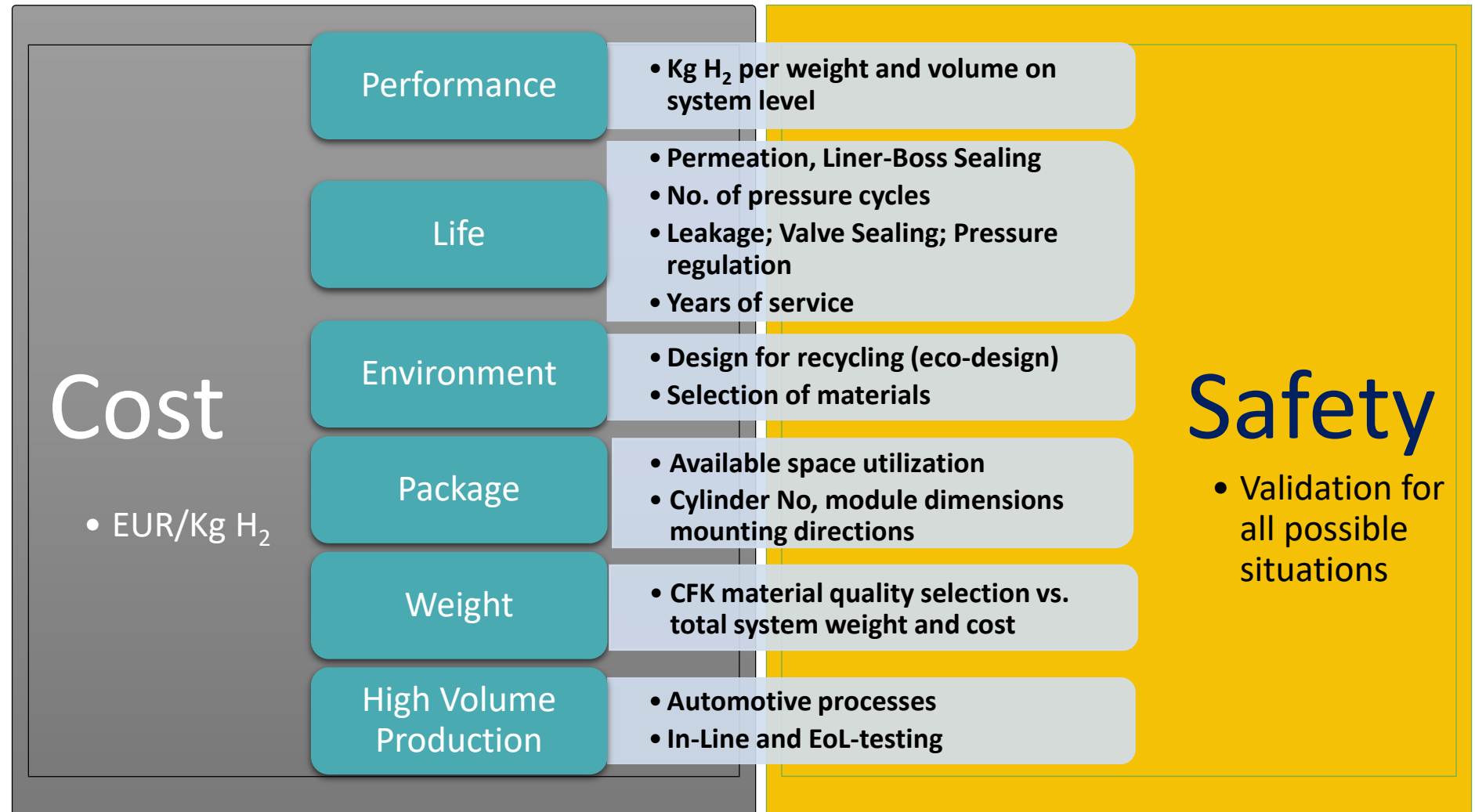

Co-funded by the
Erasmus+ Programme
of the European Union

High Pressure Storage for Hydrogen

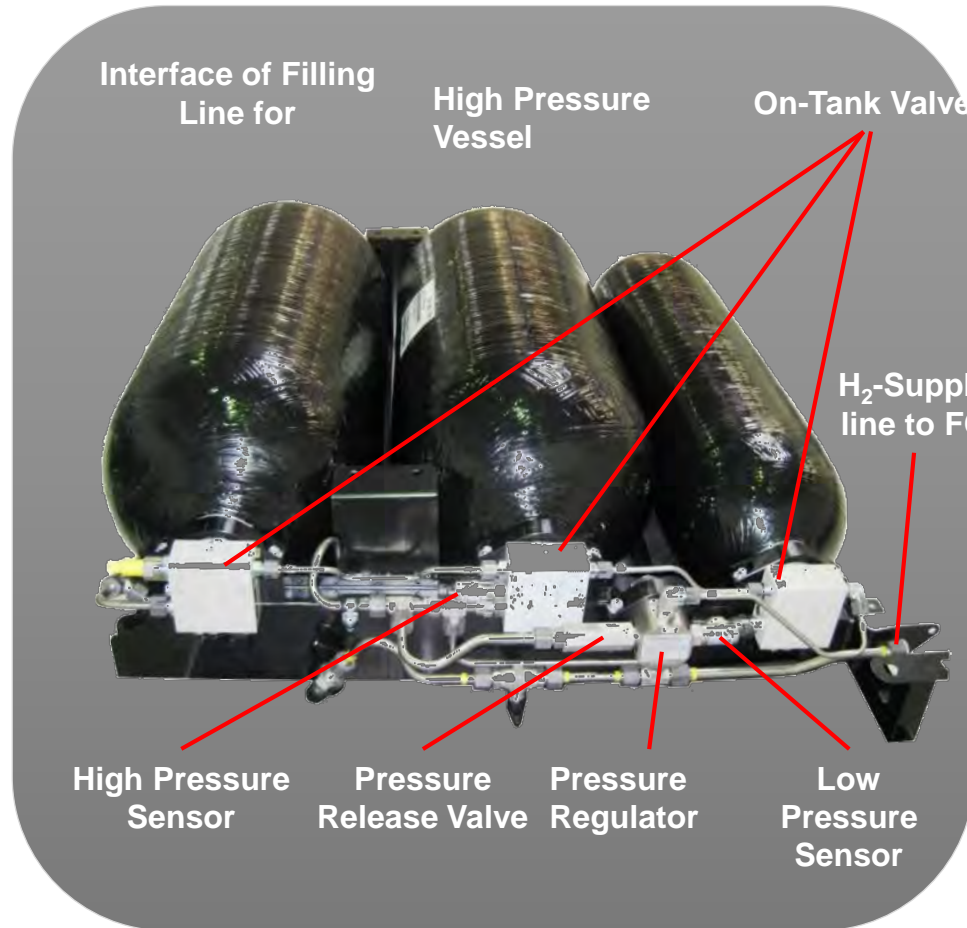

- Fully wrapped composite cylinder with plastic liner (Type-IV) and system components for storage of high compressed Hydrogen (H₂)
- Storage pressure up to 70 Mpa
- Plastic liner as Hydrogen permeation barrier



Schematic H₂-Tank system layout

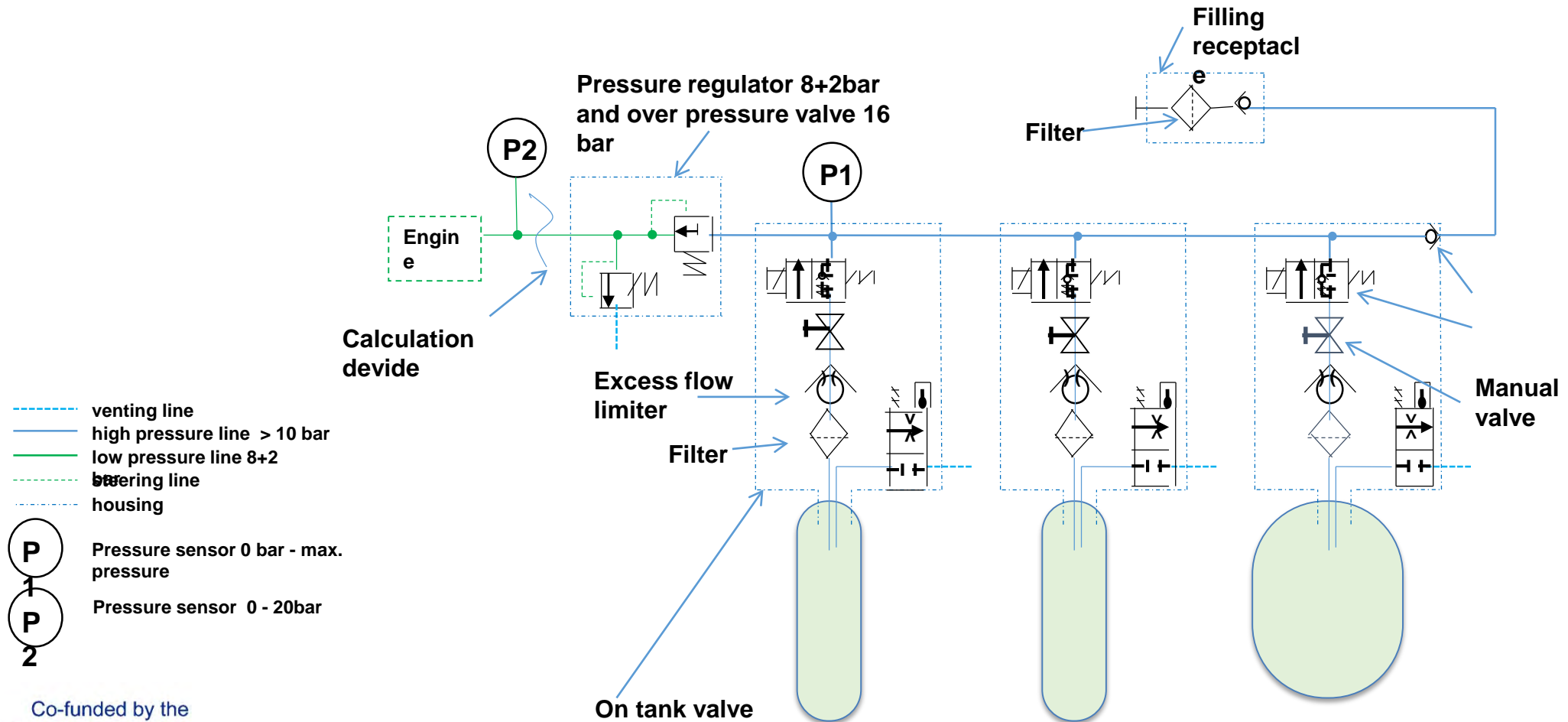



Engineering Knowledge Transfer Units to Increase Student's Employability and Regional Development



<https://www.facebook.com/unitederasmus/>



Co-funded by the
Erasmus+ Programme
of the European Union

This project has been funded with support from the European Commission. This publication reflects the views only of the author, and the Commission cannot be held responsible for any use which may be made of the information contained therein.
598710-EPP-1-2018-1-AT-EPPKA2-CBHE-JP

FOR EDUCATIONAL PURPOSE ONLY



Engineering Knowledge Transfer Units to Increase
Student's Employability and Regional Development

Options for a CO₂ reduced Mobility

Fuel Cell Vehicles



Co-funded by the
Erasmus+ Programme
of the European Union

This project has been funded with support from the European Commission. This publication reflects the views only of the author, and the Commission cannot be held responsible for any use which may be made of the information contained therein.
598710-EPP-1-2018-1-AT-EPPKA2-CBHE-JP

FOR EDUCATIONAL PURPOSE ONLY

Fuel Cell – Basics

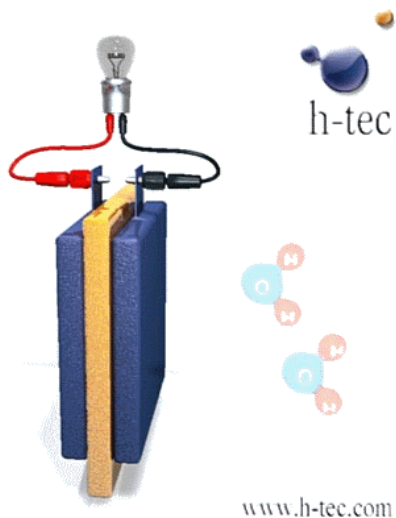

- Fuel cell (FC) is an electro-chemical energy converter with continuous supply of fuel and oxidant (air, similar ICE)
- FC is a „direct energy converter“
- The cell has a very high efficiency up to 90% (in idle)
- Low heat losses = „cold combustion“.
- Except auxiliaries (compressor and pumps) no moving parts, no noise, no CO₂, no pollutants, exhaust only water & steam

Basic overall reaction (hydrogen gas reaction, cold): $\text{H}_2 + \frac{1}{2} \text{O}_2 \Rightarrow \text{H}_2\text{O}$

- **Electrolyte: base** (NaOH, KOH), or **acid** (H₂SO₄, H₃PO₄) or **solid** (polymere, ceramics)
- Electrodes need precious metals i.e. Pt for the activation (rel. expensive!)

Fuel Cell – Base electro-chemical principle



Basic overall reaction (hydrogen gas reaction): $\text{H}_2 + \frac{1}{2} \text{O}_2 \Rightarrow \text{H}_2\text{O}$

At the electrodes (anode, cathode) two reactions happen simultaneously:

- The fuel H_2 enters a gas diffusion electrode (i.e. a porous nickel cylinder (= anode)), is getting absorbed and dissociated to: $\text{H}_2 \gg 2\text{H}^+ + 2\text{e}^-$
- During desorption each H-atom hands over a negative elementary charge e^- to the Ni-electrode (anode) which gets negative charged and the H escapes as a proton H^+ in direction electrolyte.
- Both electrodes are separated by a electrolyte i.e. a polymere (PEMFC) or an aqueous potassium hydrate (KOH), which is not conductive for the electrons but let the proton H^+ pass. On both sides of the membrane is a platin based catalyst.
- The oxygen O_2 (or air) enters the second electrode (cathode), is getting activated to O_2^- ions, by which the cathode is charged positively: $\text{O}_2 + 4\text{H}^+ + 4\text{e}^- \gg \text{H}_2\text{O}$
- At cathode the cations H^+ and anions O_2^- from neutral water (H_2O).



Fuel Cell – Base working principle

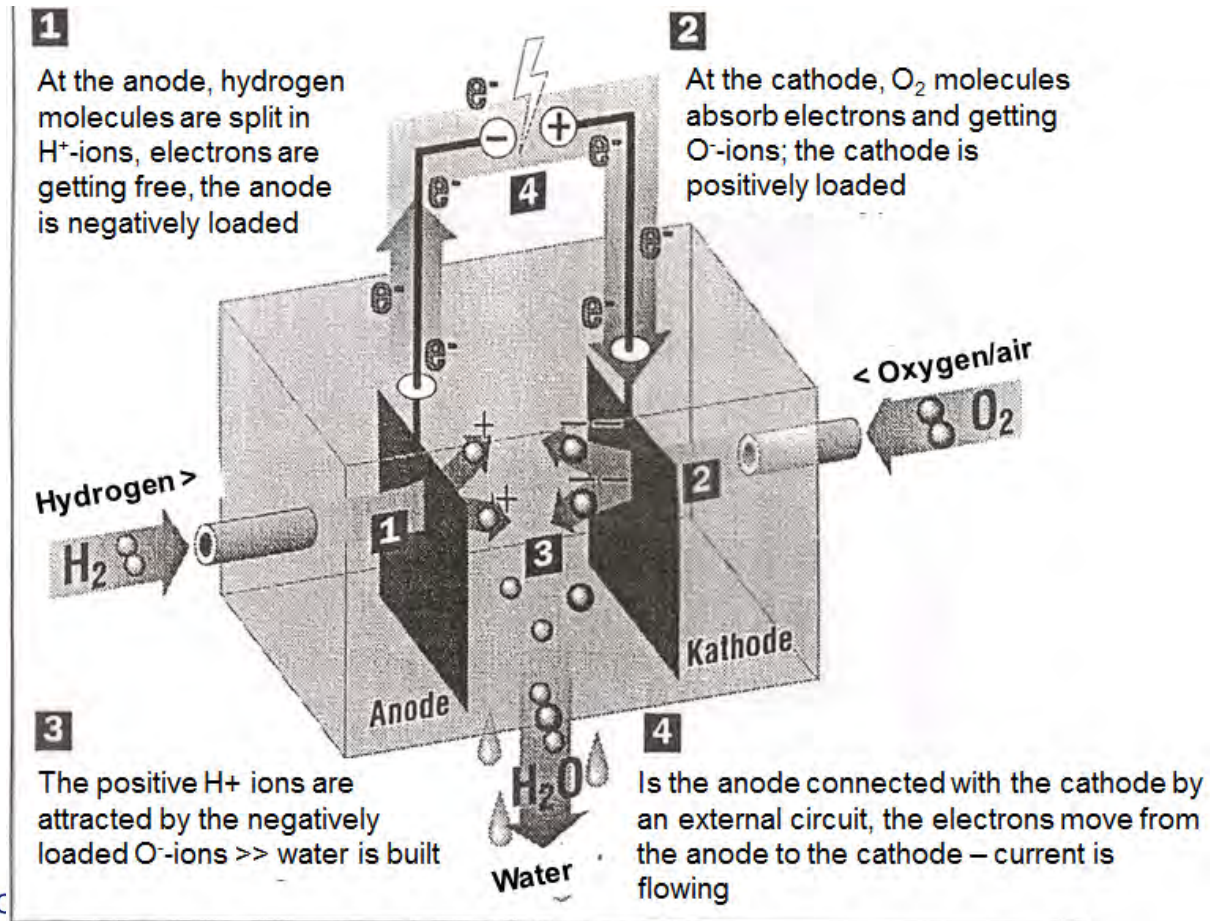

Basic principle:

- Anode and cathode are separated by an electrolyte (which also widely defines the type of fuel cell!)
- The electrolyte can be a base ($NaOH$, KOH), or an acid (H_2SO_4 , H_3PO_4) or solid (polymer, ceramics)
- The electrolyte must not be conductive for electrons but shall let (H^+)-ions pass through
- This property is very decisive for the FC, the permeability for (H^+) ions shall be very high
- The water built must be eliminated on the other hand the reaction needs a certain humidity to work well

Fuel Cell – Principle

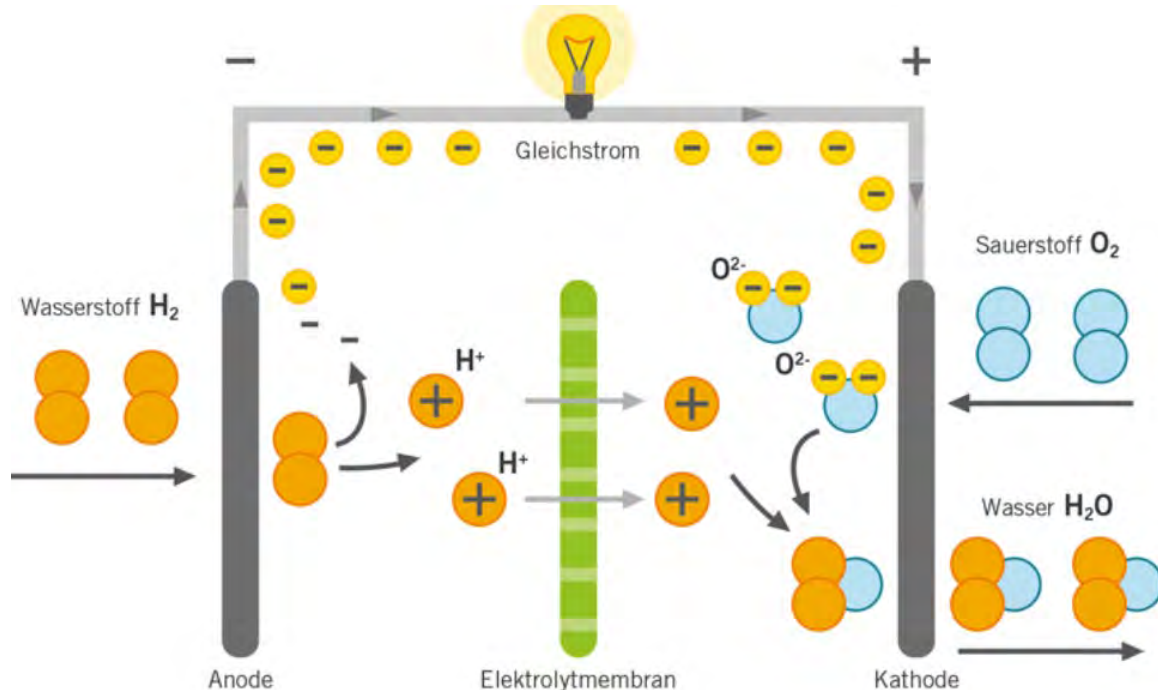

- The theoretical voltage of an hydrogen/oxygen fuel cell is 1,23 V at a temperature of 25°.
- In real fuel cells voltages between 0.5 – 1 V can be achieved – only in quiescent state voltages (OCV) higher than 1 V are measured.
- The voltage depends on the fuel, the quality of the cell and on the temperature.
- To get higher voltages a lot of cells are connected in series >> so called stacks (~400)
- Under load the chemical and electrical processes result in lowering of the voltage
- A fuel cell delivers approximately the same amount of energy in electricity and in heat
- Compared to a internal combustion engine the temperature level of the dissipated heat is relatively low, that means the delta T is low and the cooling of a fuel cell is difficult, as it requires big cooler surfaces

Types of FCs

Fuel Cell Type	Operating Temperature	Electrolyte	Ionic Conduction	Fuel gas	Oxydant	CO ₂ Tolerance	Electric Efficiency	Application	Remarks
AFC Alkaline Fuel Cell	60 - 80 °C	KOH(OH ⁻)	OH ⁻	H ₂	O ₂	< 1 ppm	Cell: 60 - 70 % Syst.: 60%	Space, Military, Vehicles	needs pure H ₂ and O ₂ corrosion!
DMFC Direct Methanol FC	~ 80 °C	Proton conduct. Membran	H ⁺	CH ₃ OH	O ₂ (Air)		Cell: 20 - 30 %	Small devices, Camping	low efficiency
PEMFC LowTemp Polymer Membran FC	60 - 120 °C	Proton conduct. Membran	H ⁺	H ₂	O ₂ (Air)	< 100 ppm	Cell: 50 - 75 % Syst.: 45 - 60%	Vehicles, Space, Stationary devices	high power density
PEMFC HighTemp Polymer Membran FC	120 - 200 °C	Proton conduct. Membran	H ⁺	H ₂	O ₂ (Air)	< 500 ppm	Cell: 50 - 75 % Syst.: 45 - 60%	Vehicles, Space, Stationary devices	high power density
PAFC Phosphoric Acid FC	160 - 200 °C	Concentrated Phosphoric Acid	H ⁺	H ₂	O ₂ (Air)	< 1 %	Cell: 55 % Syst.: 40%	smaller power stations big vehicles	corrosion problems
MCFC Molten Carbonate FC	~ 650 °C	Alkali carbonate	CO ₃ ²⁻	CH ₄ ; Coal & bio gas, H ₂	O ₂ (Air)	ok	Cell: 55 % Syst.: 50%	power stations big vehicles	Complex operating, corrosion problems
SOFC Solid Oxide FC	~ 1000 °C	doped Zirconium oxide	O ²⁻	H ₂ , CO, Hydrocarbon	O ₂ (Air)	ok	Cell: 60 - 65 % Syst.: 55 - 60 %	power stations, Auxilliary power units	

Fuel Cell types: Temperature ranges

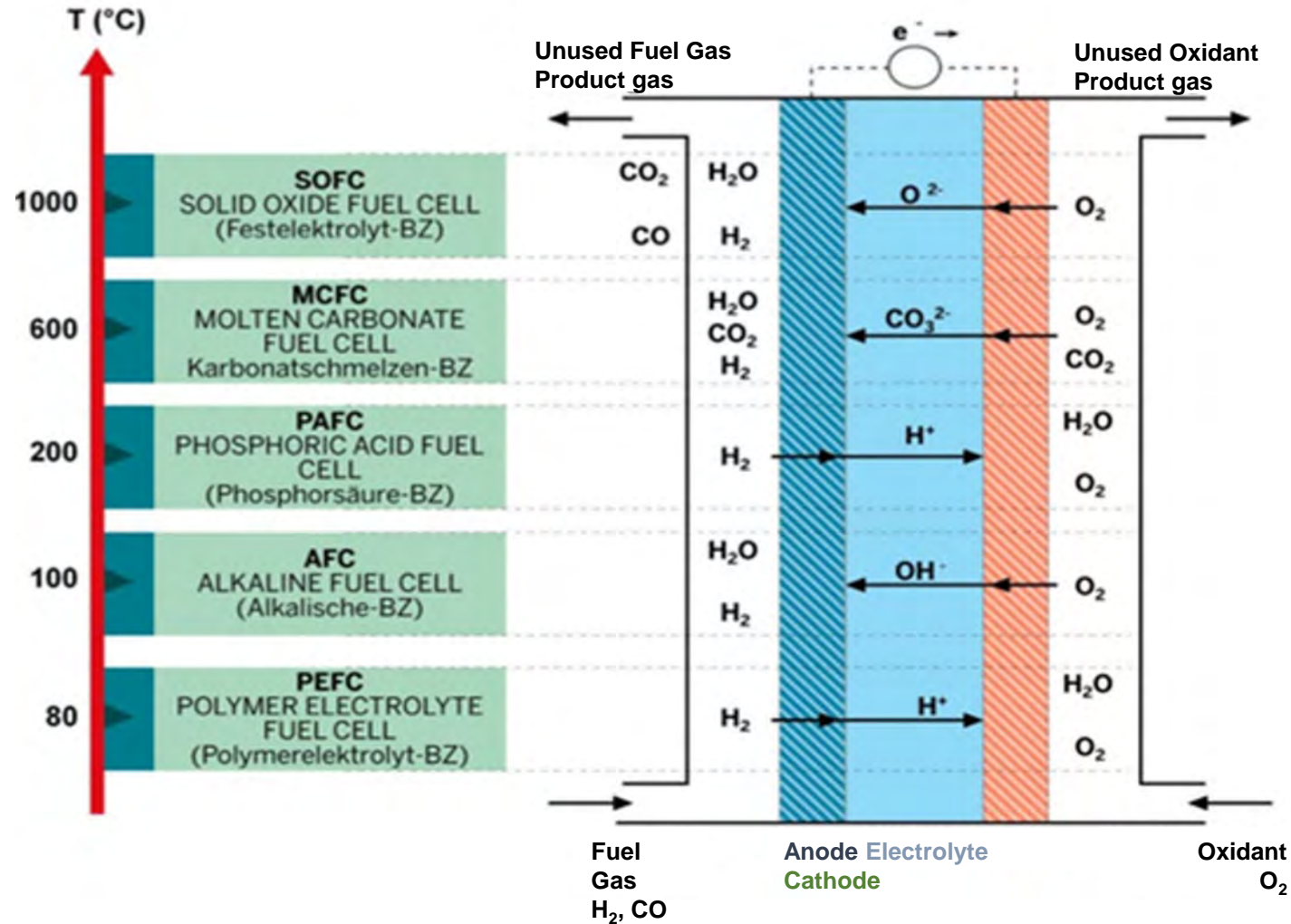

PEM Stack Design

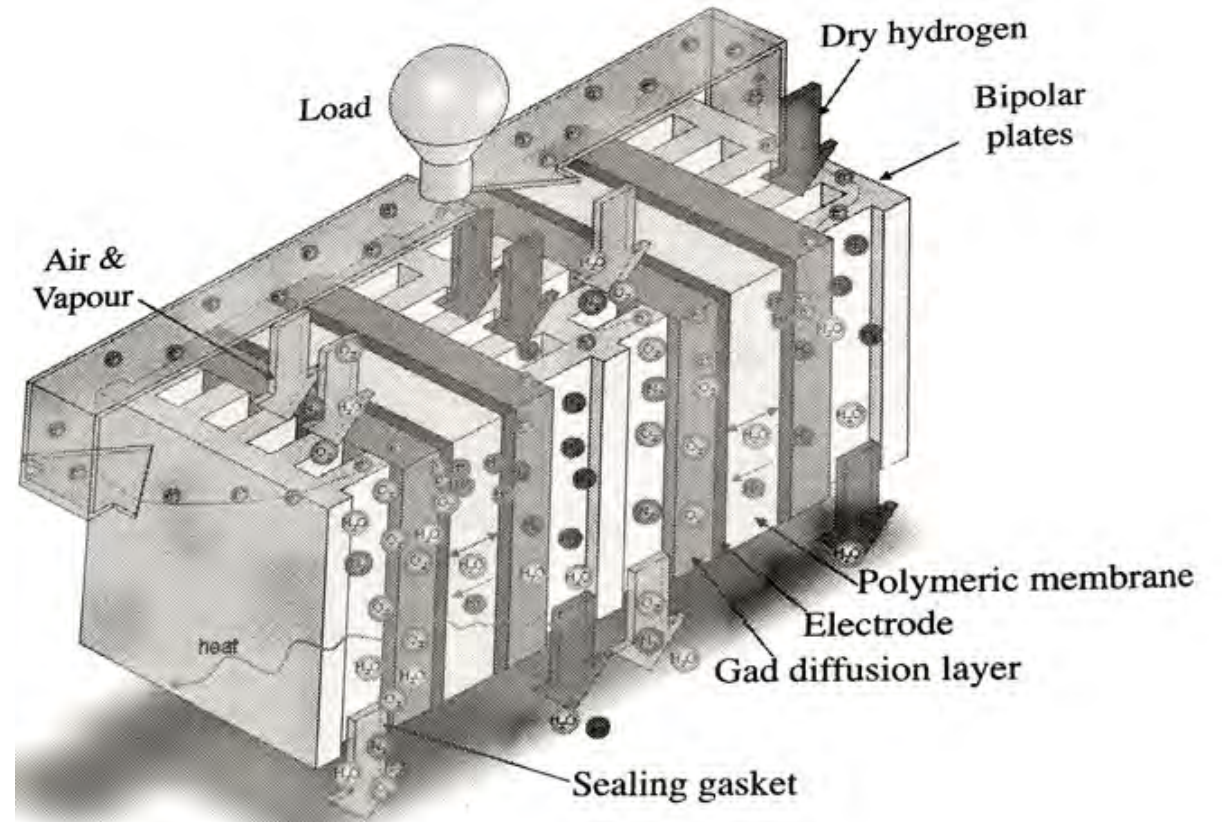
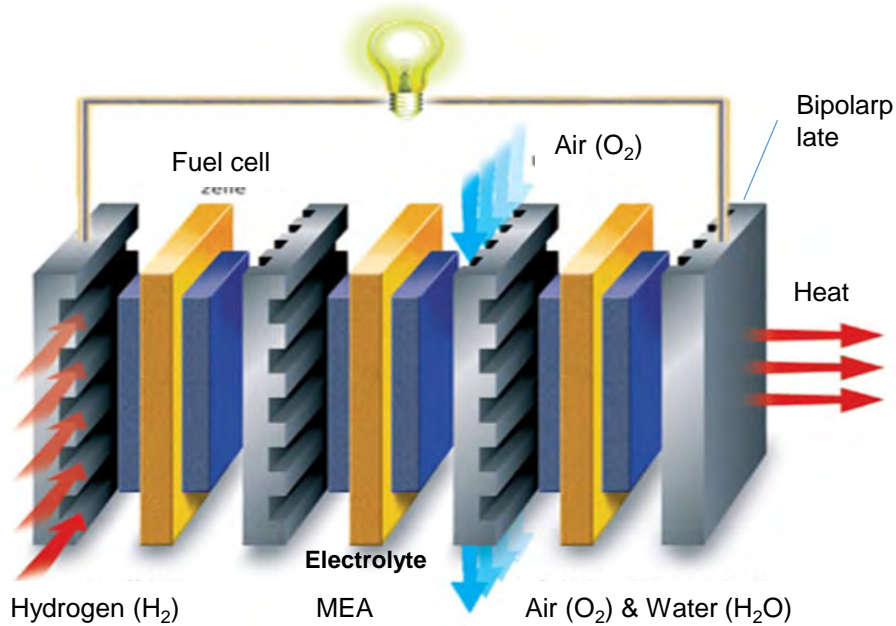

PEM FC Design

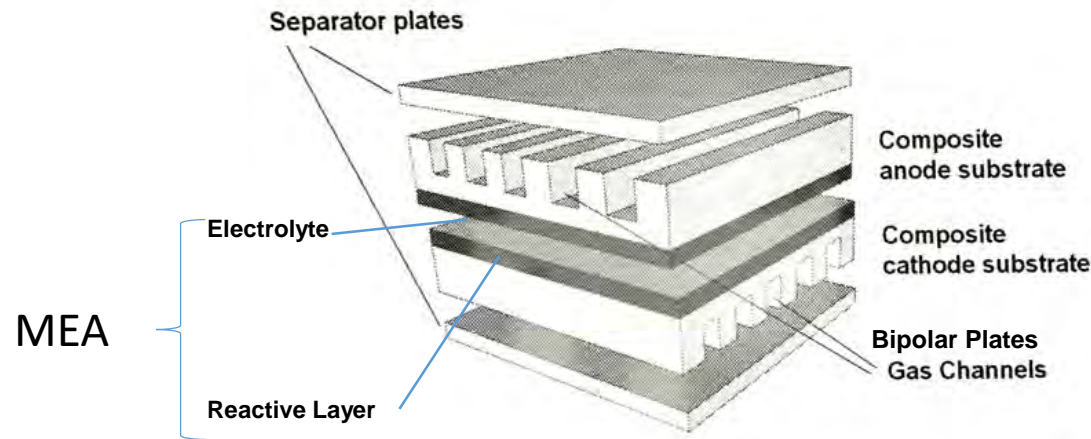

MEA (membrane electrode assembly) is an assembled stack of proton exchange membranes (PEM) used in fuel cells and electrolyzers

PEMFC Proton Exchange Membrane Fuel Cell:

- Bipolar plate as electrodes with milled gas channels (CFD optimised gas flow!), made from metal or conductive synthetics eventually „reinforced“ or made conductive by nano carbon pipes
- porous carbon-papers (high surfaces – 1g carbon 200m²)
- Reactive layer, in most cases on the Ionomer membrane; then four phases are in porous contact: catalysator (Pt), electron conductor (soot or carbon-nano materials), proton conductor (Ionomer)
- Proton conductive Ionomer membrane: gas tight and not conductive for electrons

Fuel cell-System – H₂ / Air

Major components/auxiliaries

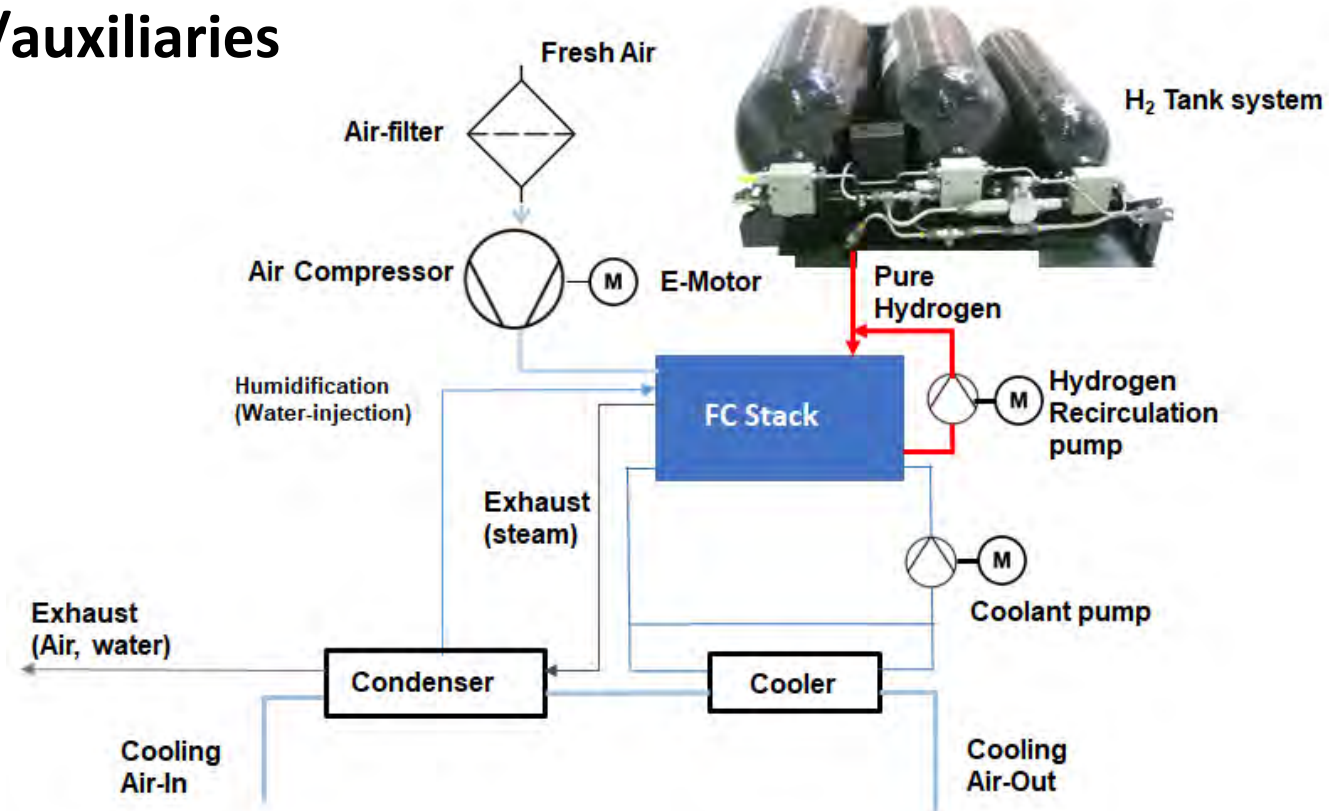

Auxiliaries: air filter, compressor, hydrogen recirculation system, cooling pump, condensator, cooler, humidifier



Fuel Cell System – Methanol / Air

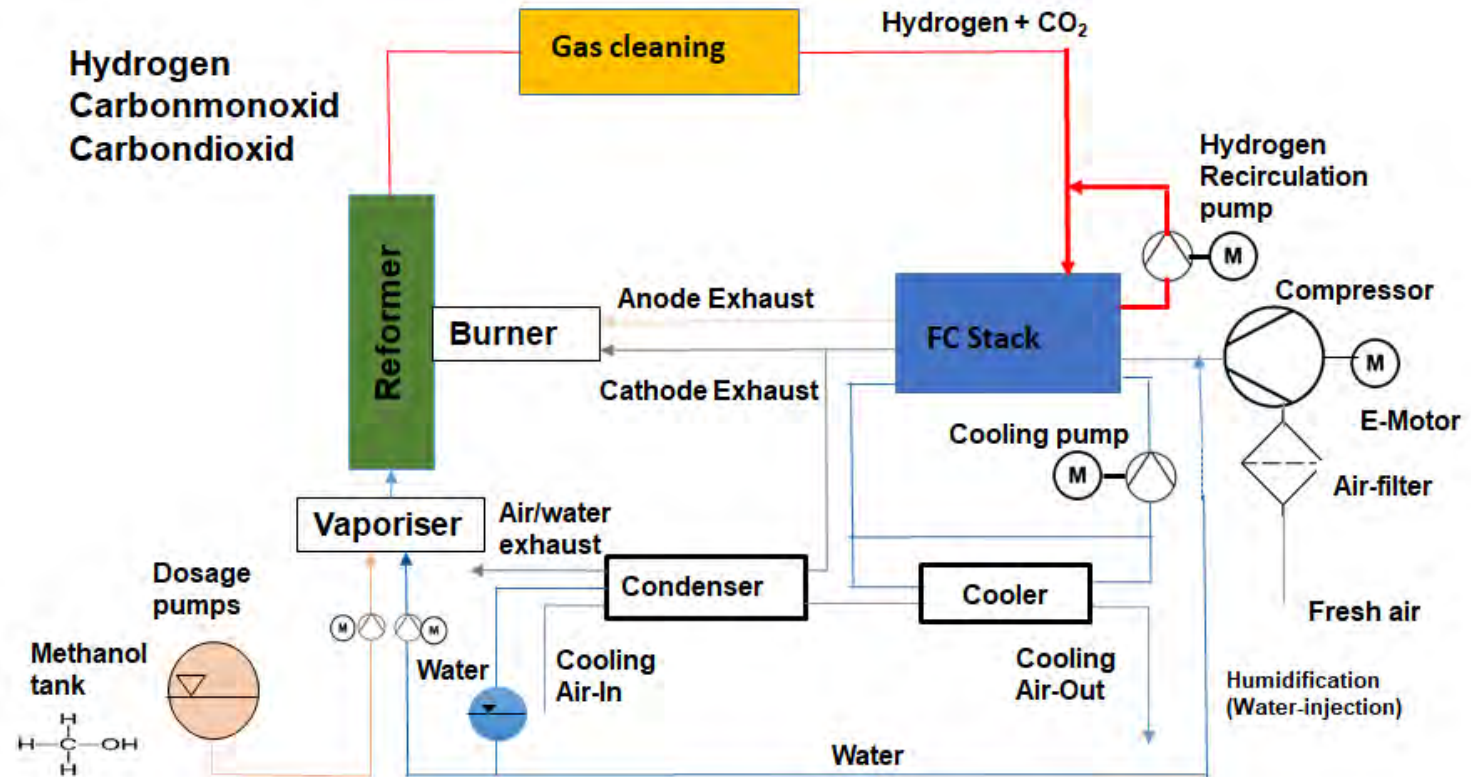

Auxiliaries: methanol tank, dosage pumps, vaporizer, reformer, CO cleaner, air filter, compressor, cooling pump, compensators, cooler, humidifier

FC Cell / Stack / System Efficiency

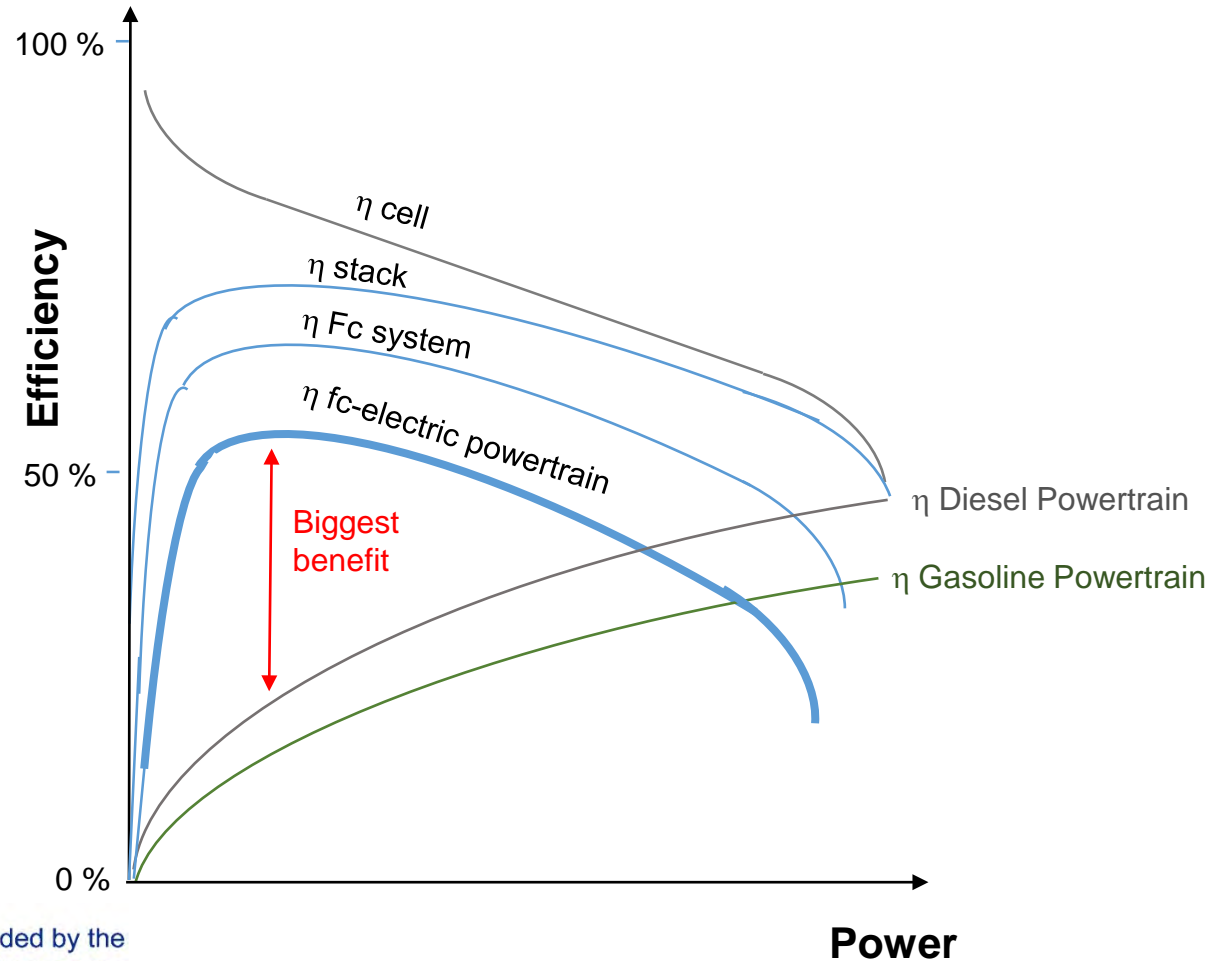

- Compared to diesel or gasoline powertrain, better efficiency in part load condition (up to 60%) = city driving
- For higher power demand use multiple stacks



Key development issues / open questions



- **Costs:** Reduction of Pt content ongoing (target: not more than in a standard ice catalyst!); attempts to create “Pt-free” PEMs by substitution cat materials by using nickel (?)
- Electrolyte membrane in the hand of a few companies (3M) > high price

Efficient Auxiliaries:

- High sensitivity against dust (very efficient air filters needed) and impure hydrogen need to be avoided
- Suitable oil-free compressors with highest efficiency (biggest parasitic loss!), compressor noise (encapsulation)! new types?
- Efficient recirculation pump (exchanged by ejectors/venturi nozzles) and coolant pumps
- Humidifier necessity(?, life time issue), dynamic behavior (?)

- Cooling of low temperature PEM (80-100°C); DT small against ambient > big surfaces in cooler; space availability in the car?; this can limit possible vehicle peak power!
- Improving water management (water out!); purging!; necessary for cold start
- Condenser design for avoiding freezing

- **Efficiencies over lifetime (avoid catalyst degradation);**
- **Life time / catalyst degradation (up to 20%, acceptable?)**
- **Hydrogen fuel related questions:** production, transport, fuel stations (infra structure build up)



Applications by power ranges

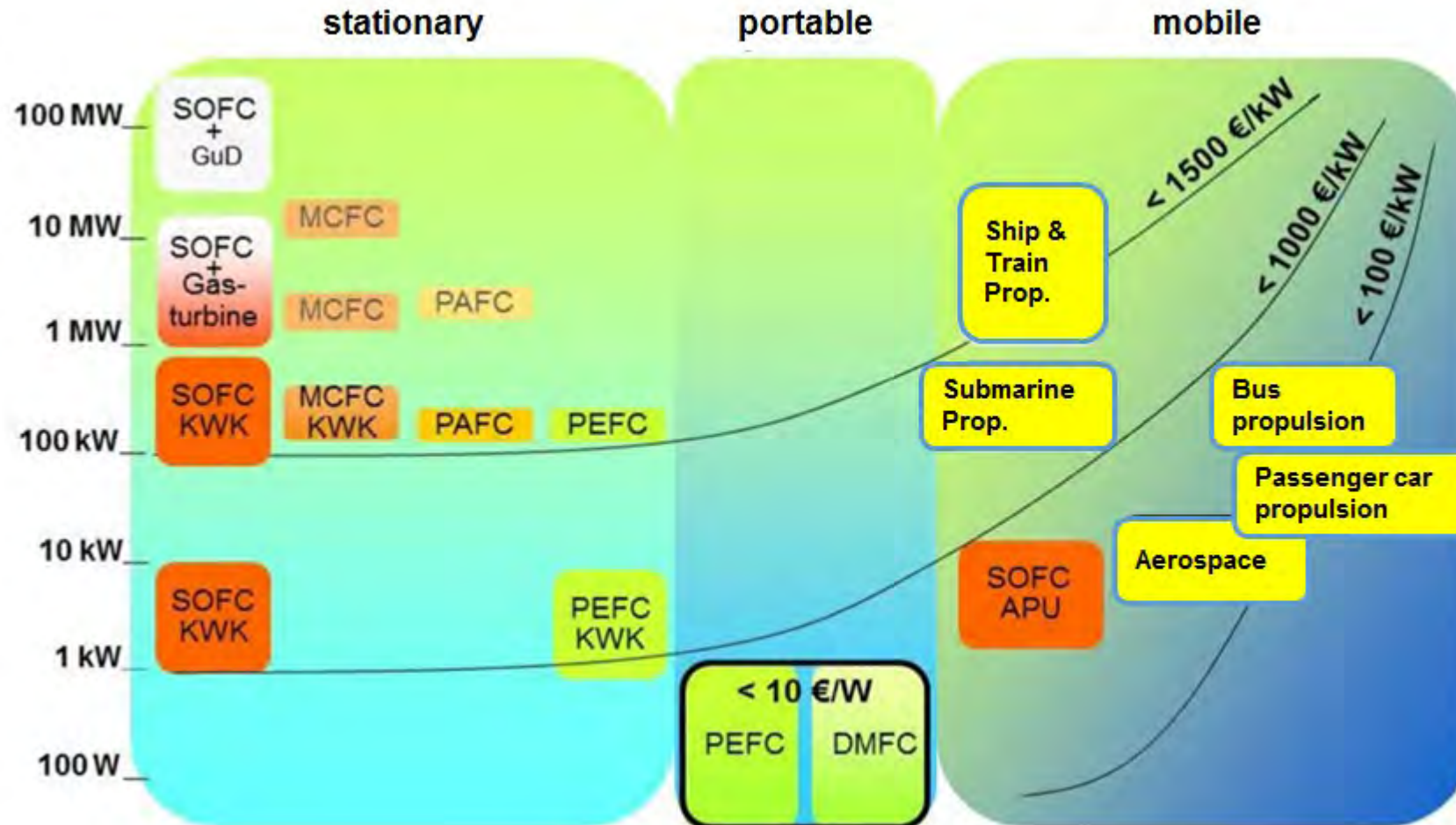

Applications – Roles in Mobility

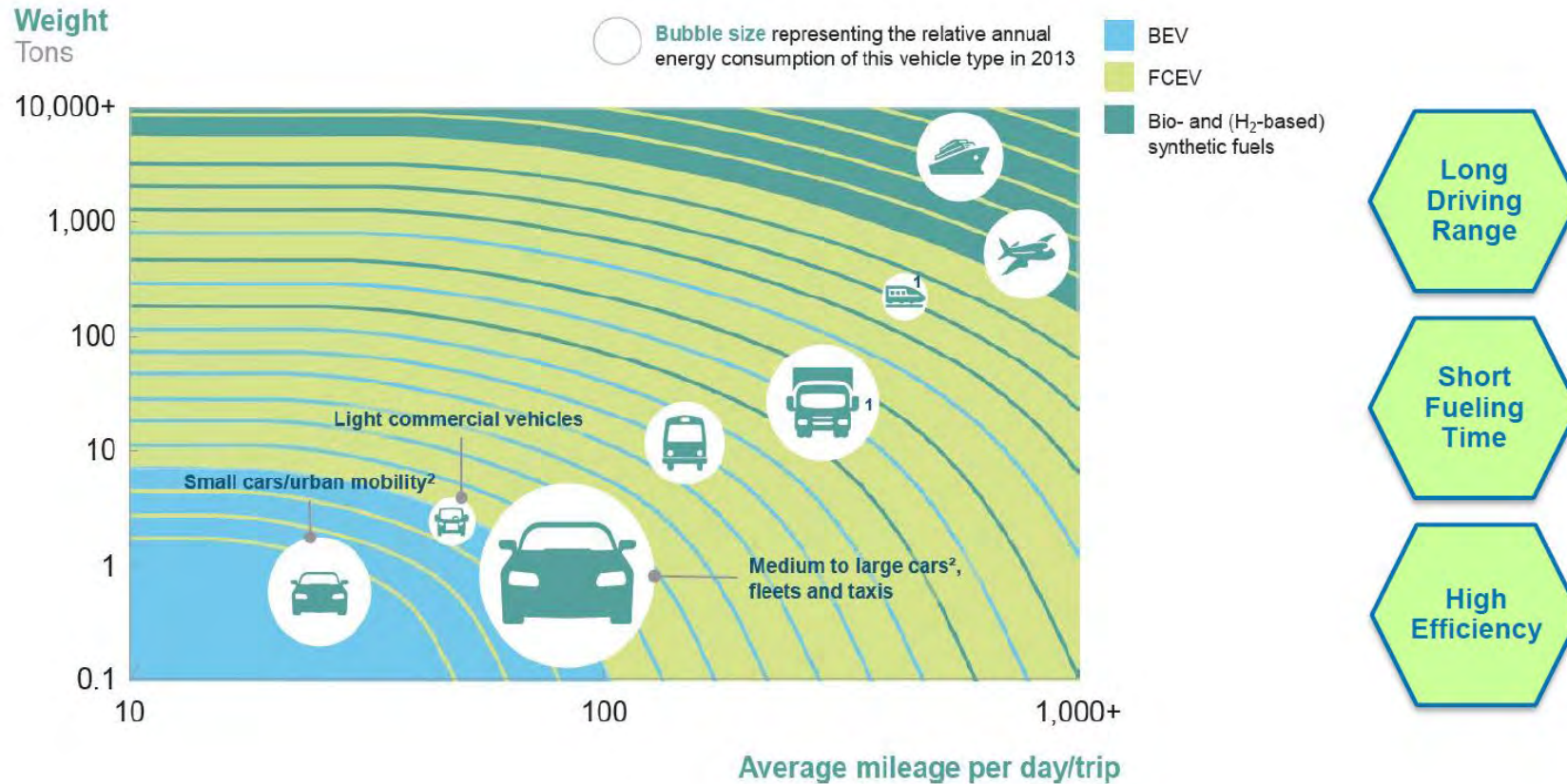

Source: Hydrogen Council 2017



Co-funded by the
Erasmus+ Programme
of the European Union

FOR EDUCATIONAL PURPOSE ONLY

Other Application of FCs - Rail

First narrow-gauge railway in the world powered by „green“ hydrogen



Mayrhofen

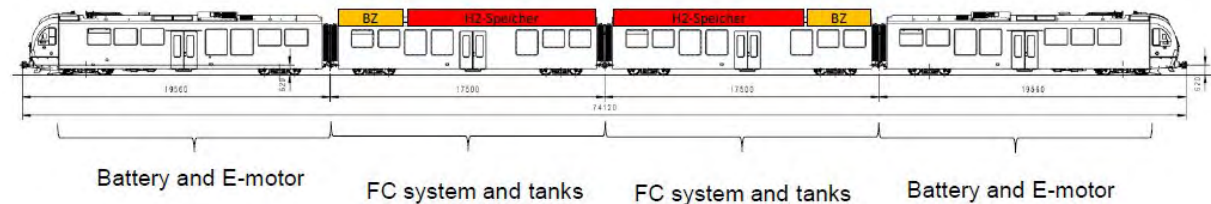
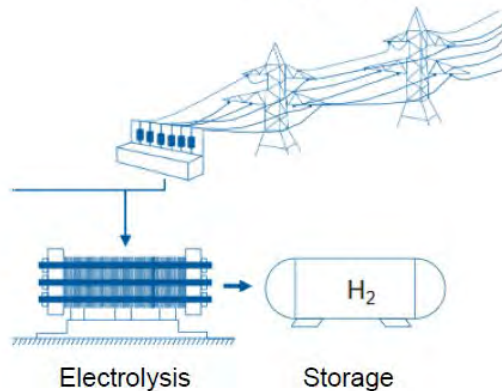

Fuel Cell Powertrain

Principal Layout / Components:

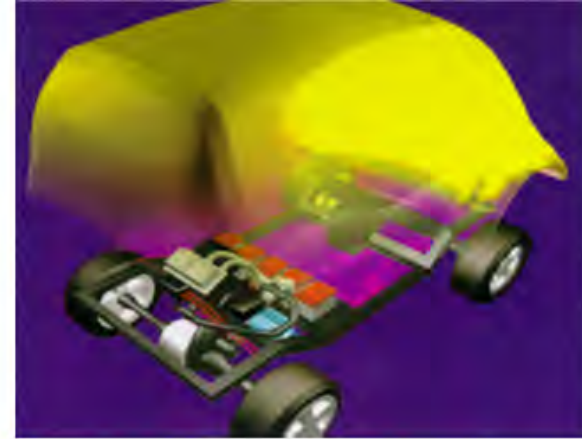
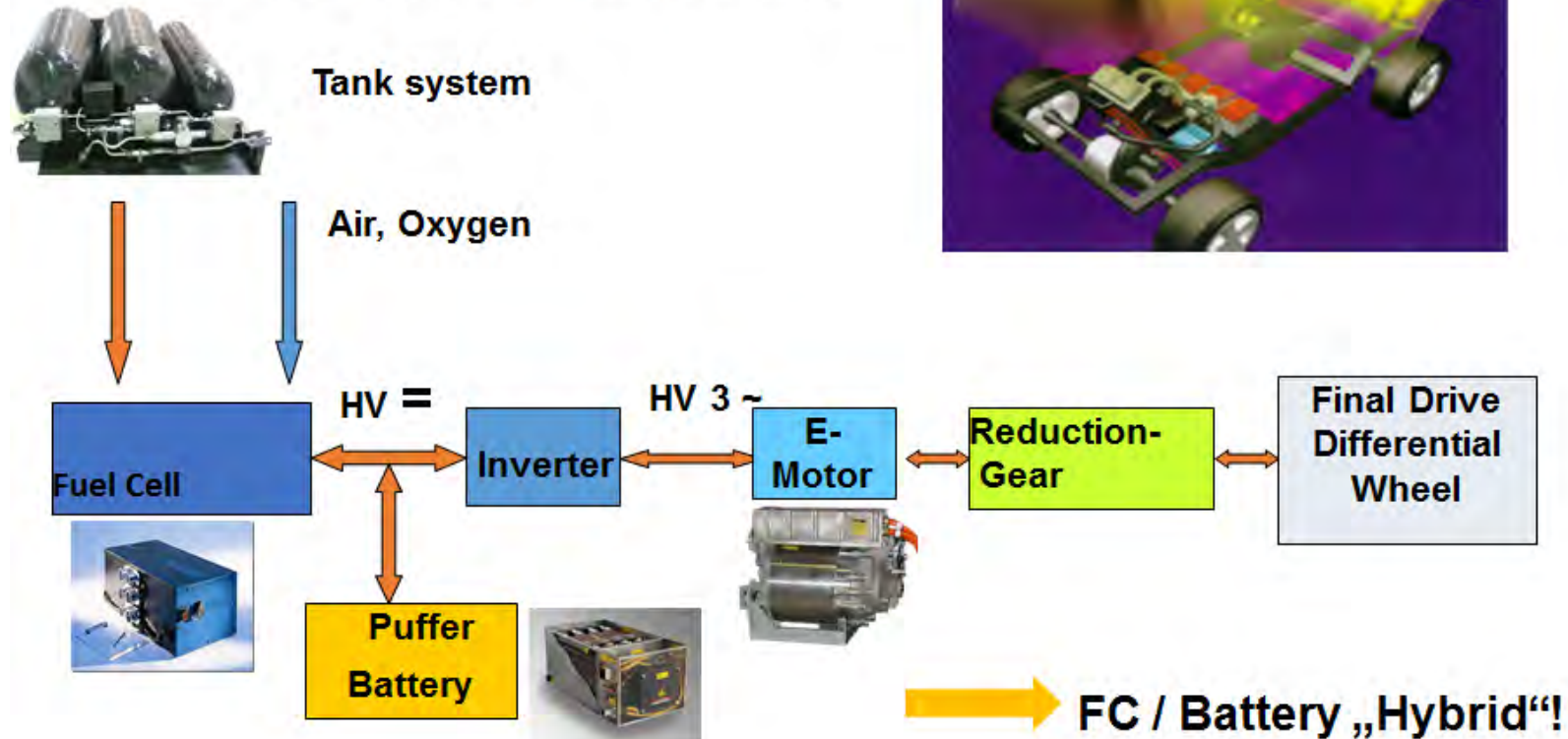

Overview current Fuel Cell Vehicles



- Typical today's Fuel Cell Vehicle Specs:

- PEM Fuel cell
- Appr. 5 kg H₂ in gas tanks @700 resp. @350bar
- SUV, mid & compact class configured as FC – Battery Hybrid, no transmission
- „all performance vehicle“: Range >500km, typ. power 100kW full transport capability

- Almost all OEMs are developing FCVs!

Comittment for development and market introduction of FCVs in 2015 - 2017 by:

Daimler AG, Ford Motor Company, General Motors Corporation/Opel, Honda Motor Co., Ltd., Hyundai Motor Company, Kia Motors Corporation, die Allianz Renault SA und Nissan Motor Co., Ltd. und Toyota Motor Corporation



Co-funded by the
Erasmus+ Programme
of the European Union

Hyundai ix35 Fuel Cell



First series production hydrogen fuel cell vehicle



Co-funded by the
Erasmus+ Programme
of the European Union

Hyundai iX35 Fuel Cell

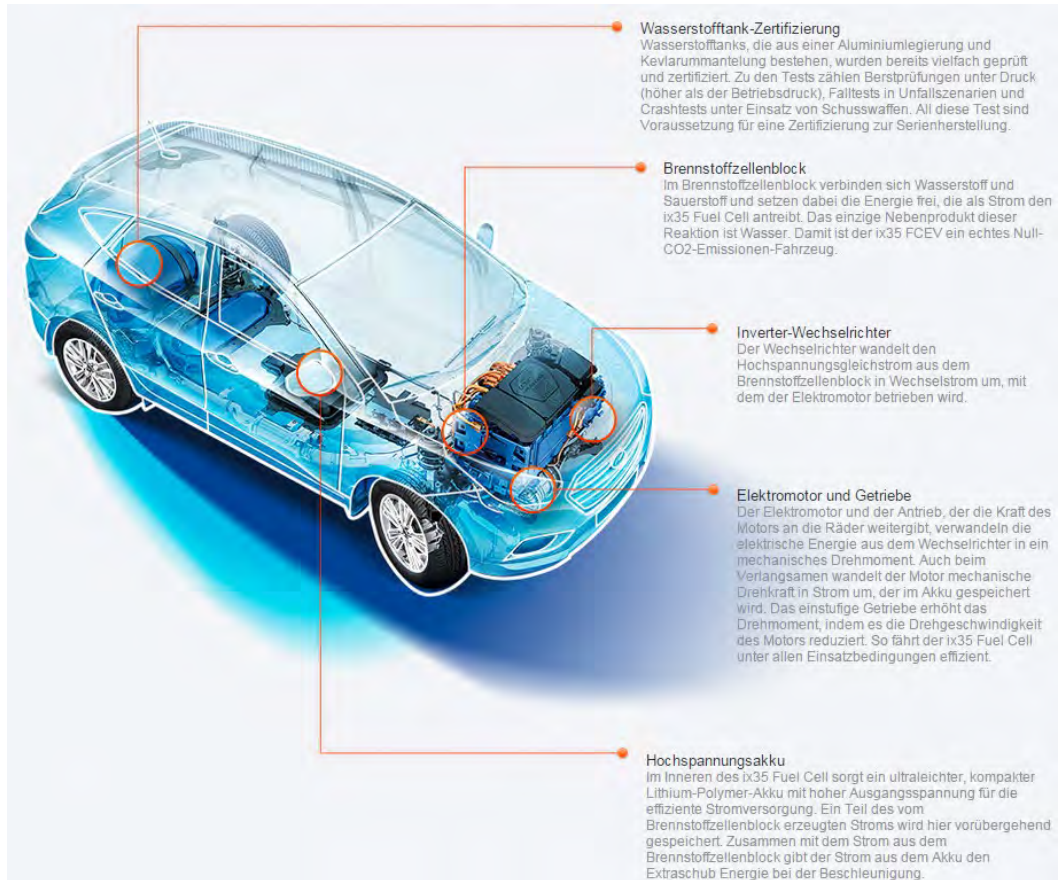

Fuel cell	Max. Power (kW)	100
Battery	Lithium-Polymer-Akku (kW)	24
Asynchronous motor (front motor)	Max. Leistung (PS)	136
	Max. Torque (Nm)	300
	Max. Power (kW)	100
	Max. Speed (km/h)	160
	Acceleration (0–100 km/h in sec.)	12,5
Drive train	Transmission type	reduction transmission
	Fuel	Hydrogen
Fuel consumption	Fuel Consumption (City traffic, in kg per 100km)	0,8896
	Fuel consumption (extra urban/highway, in kg per 100km)	0,9868
	Fuel Consumpt. total (in kg per 100 km)	0,9512
	CO ₂ -Emission (total, in g per km)	no, only water steam
	Volume hydrogen tank total (l)	144



Co-funded by the
Erasmus+ Programme
of the European Union

Hyundai NEXO – the successor of iX35



Co-funded by the
Erasmus+ Programme
of the European Union

Hyundai NEXO - the successor of iX35



Mit dem Hyundai NEXO schon heute in die Zukunft.

Enorme Reichweite, unvergleichliche Dynamik, zukunftsweisendes Design: Der neue Hyundai NEXO ist das Ergebnis unserer 20-jährigen Pionierarbeit auf dem Gebiet der Wasserstoff-Antriebe – das perfekte Null-Emissions-Auto für jeden Tag! Der hocheffiziente Antrieb des Hyundai NEXO verbindet CO₂-freie Wasserstoff-Technologie mit der Robustheit und der Dynamik eines SUV. So meistert er Einkauf, Dienstreise oder Wochenendreise gleichermaßen souverän.



Maximale Leistung
120 kW



Reichweite bis zu
756 km



Maximales Drehmoment
395 Nm



Tankzeit (Schnell)
<5 Min.



Beschleunigung (0-100 km/h)
9,5 Sek.



Höchstgeschwindigkeit
179 km/h



Volldigitales Display.
Das Armaturenbrett beherbergt ein 12,3 Zoll großes Navigations-Display und eine weitere 7-Zoll-Instrumentenanzeige.



4.670 mm



1.860 mm



1.630 mm

Kraftstoffverbrauch (Wasserstoff) Hyundai NEXO 120 kW (163 PS) innerorts: 0,77 kg H₂/100 km; außerorts: 0,87 kg H₂/100 km; kombiniert: 0,84 kg H₂/100 km. CO₂-Emission kombiniert: 0 g/100 km; CO₂-Effizienzklasse: A+. Die angegebenen Verbrauchs- und CO₂-Emissionswerte wurden nach dem vorgeschriebenen WLTP-Messverfahren ermittelt und in NEFZ-Werte umgerechnet.



Co-funded by the
Erasmus+ Programme
of the European Union

Hyundai NEXO - tank system integration



Plastik „exhaust pipe“



Pressure regulator



Co-fu
Erasmus+ Programme
of the European Union

Hyundai NEXO - engine compartment & battery



Toyota FCHV - Vehicle Integration



FCHV-4 (older)

- Hydrogen fuel
- 90kW PEM FC stack with high power density ($>1.2\text{kW/kg}$)
- 80kW e-motor
- High pressure hydrogen tank
- NiMH battery (=Prius)

FCHV-5 : CHF Clean hydrocarbon fuel reformer

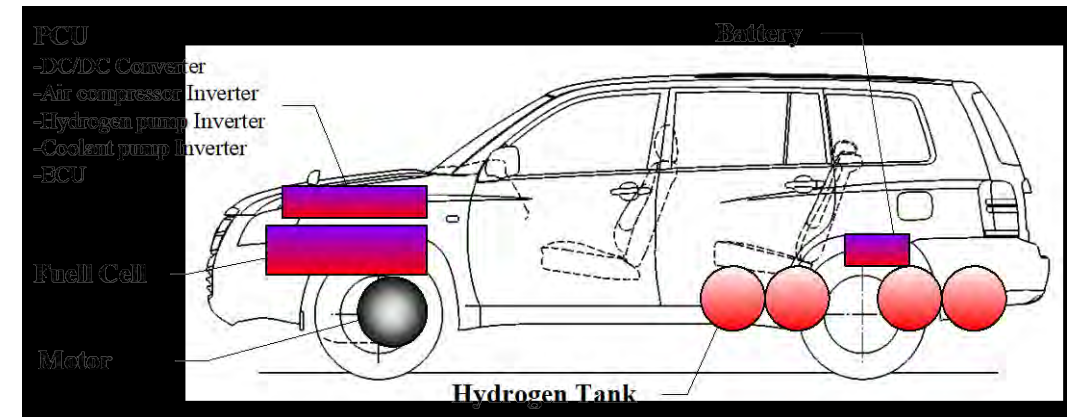

Toyota Mirai 2015



Co-funded by the
Erasmus+ Programme
of the European Union

Toyota Mirai Specifications



- P=100 kW; 65% eff.; 3kW/Lit
- Range: 500 to 700 km (Jp08)
- Cold start: - 30°C
- Price:< 80.000.-€
- The costs of the fuel cell have been reduced to 20 % compared to FCHV-adv (2008) and is double powerful at same size!



Honda FCX - Clarity



- 100 kW Honda Vertical Flow (V Flow) hydrogen fuel cell
- electric motor rated at 100 kW and 256 Nm from 0 to 3056 rpm
- Hydrogen tank (4.1 kg @ 350 bar)
- 60 miles per kilogram of hydrogen
- Range 372 (589) km
- Refueling 5 min

Vehicle	Model year	Combined fuel economy	City fuel economy	Highway fuel economy	Range
Honda FCX Clarity	2014	59 mpg-e	58 mpg-e	60 mpg-e	231 mi (372 km)
Honda Clarity Fuel Cell	2017	67 mpg-e	68 mpg-e	66 mpg-e	366 mi (589 km)



Co-funded by the
Erasmus+ Programme
of the European Union

Honda FCX - Clarity FC&Tank Appl.



- 100 kW e-motor in front
- hydrogen fuel cell in tunnel
- Big hydrogen tank over rear axle compromising luggage compartment

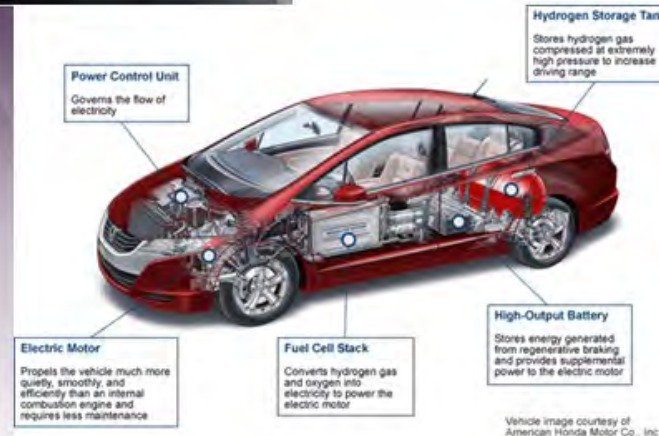
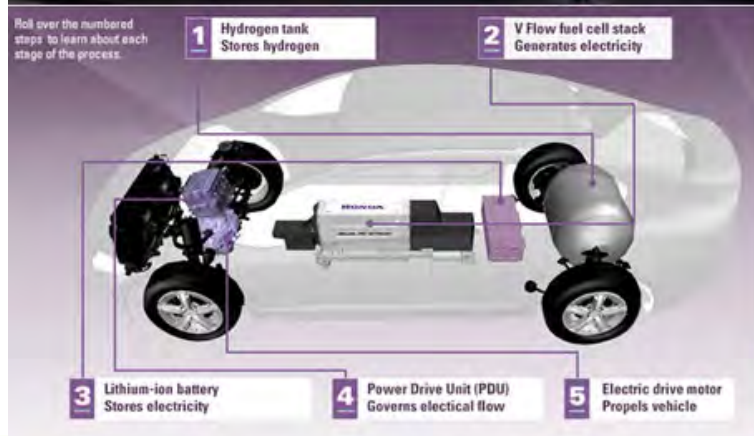

Co-funded by the
Erasmus+ Programme
of the European Union

Honda FCX - Clarity Tank location



Co-funded by the
Erasmus+ Programme
of the European Union

FOR EDUCATIONAL PURPOSE ONLY

Mercedes-Benz FCV

Mercedes-Benz GLC F-CELL: Fuel Cell Electric Vehicle with Plug-in-Technology



Co-funded by the
Erasmus+ Programme
of the European Union

Mercedes-Benz Plug-In FCV



Next Generation Fuel Cell Vehicle:
„The Fuel Cell gets a Plug!“



Co-funded by the
Erasmus+ Programme
of the European Union

Mercedes-Benz Plug-In FCV



Next generation fuel cell powertrain

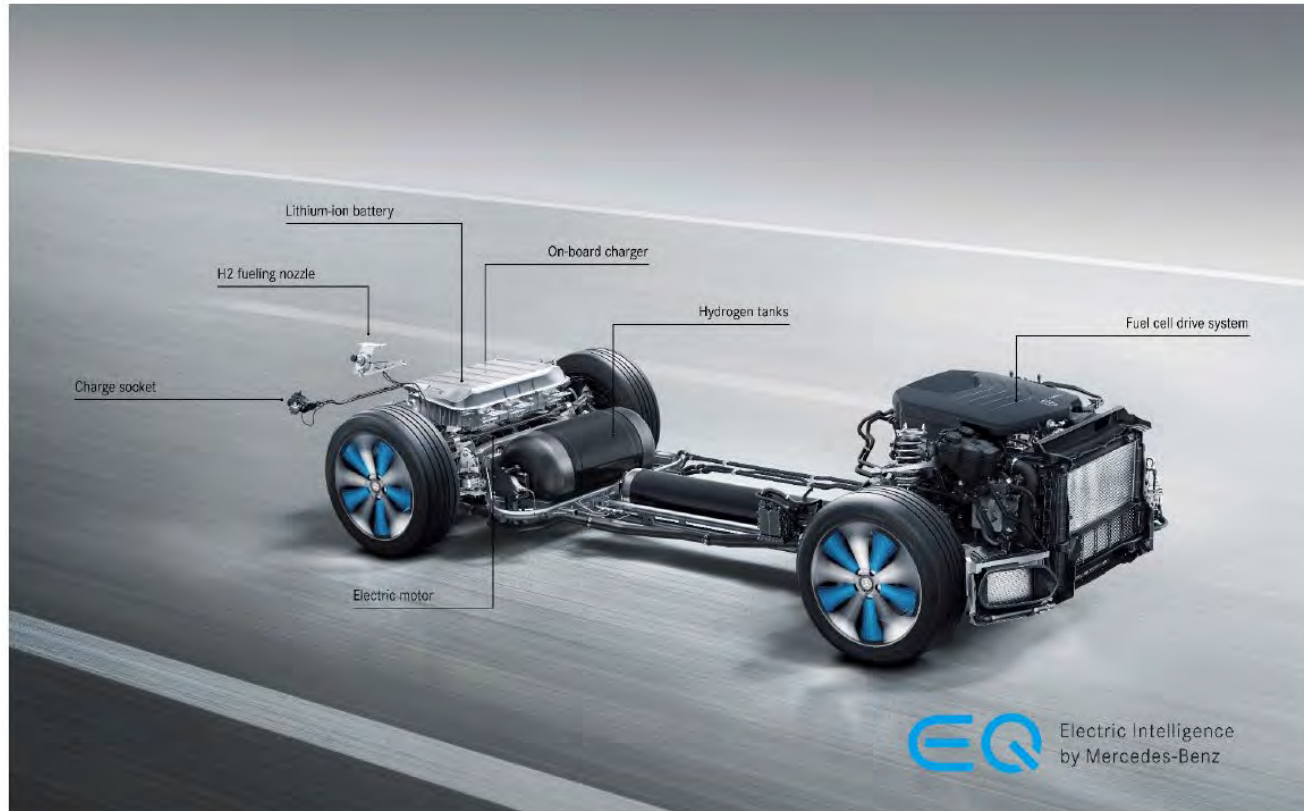

Combined electrical consumption (kWh/100 km)	13,7
H ₂ -Range in hybrid mode (NEDC) (km)	478
Battery electric range in battery mode (NEDC) (km)	51
Engine	Electric motor
Rated output (kW/PS)	155 (211)
Peak torque (Nm)	365
Battery	Lithium-Ion
Energy content (gross/net) (kWh)	13,5 /9,3
Fuel cell	PEM
Hydrogen tank capacity (kg) (usable for SAE J2601, 2014 or more recent)	4,4
top speed (km/h)	160 (governed)



Co-funded by the Erasmus+ Programme of the European Union

Daimler AG

FOR EDUCATIONAL PURPOSE ONLY

Mercedes-Benz Plug-In FCV

Daimler's Next Generation Fuel Cell Engine

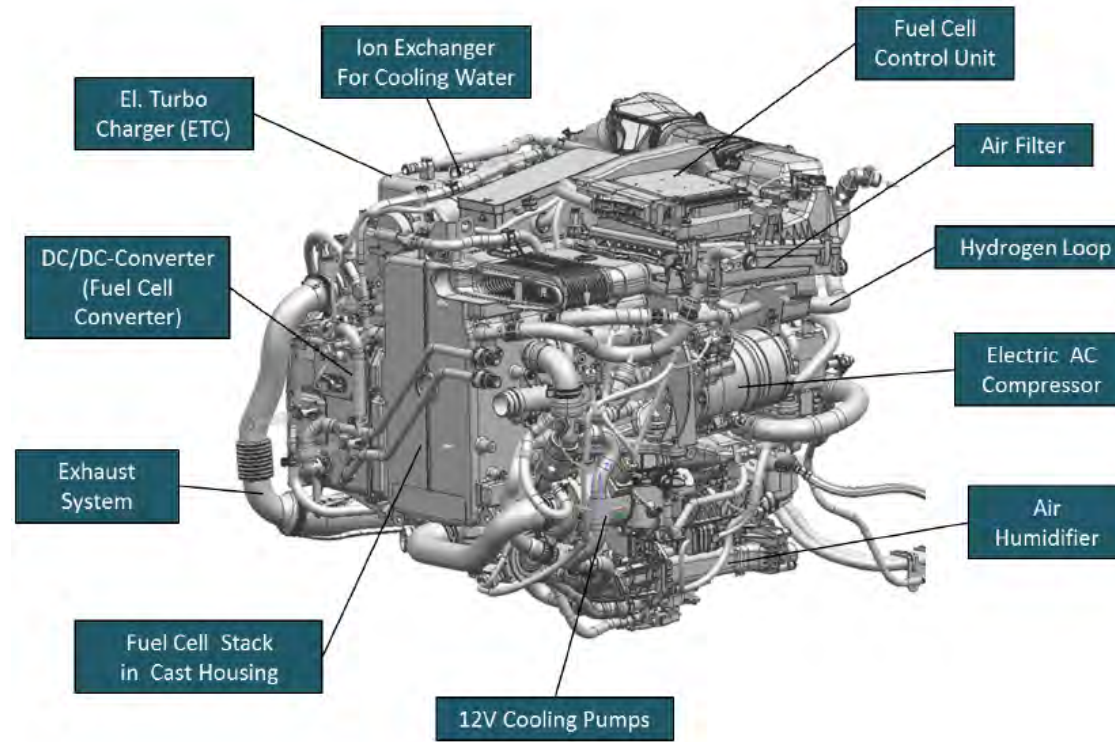

- High level of component integration
- Increase in fuel cell stack power density by ~ 100 % compared to B-Class F-CELL
- Introduction of electric turbo-compressor for air supply
- Absolute platinum content in fuel cell stack reduced by 90% compared to B-Class F-CELL
- Increased amount of series-produced carry-over parts (e. g. air filter, coolant pump)



Audi A7 h-tron (2015)



Main Specs:

- Plug-In FCV
- PEM FC (kW?) operating @ $\sim 80^{\circ}\text{C}$;
- Cold start ability: -28°C
- 4 Hydrogen tanks (5 kg @ 700 bar)
- ~ 100 km per kilogram of hydrogen
- 2 PSM electric motors rated at 85/114 kW and 270 Nm; planetary gear 7,6:1
- Battery: Li-Ion 8,8 kWh
- Range 500 (50 pure electric) km
- Efficiency powertrain $\sim 60\%$
- 0 – 100 km/h 7,9 sec



Co-funded by the
Erasmus+ Programme
of the European Union

Light Commercial FC-REEV (Magna Steyr) FC Range Extended Electric Vehicle (FV- Plug-In)



- Base Mercedes E-Vito (Bolt)
- Combination of a bigger capacity battery with a smaller power FC (=REX)
- Application: delivery van for more than one shift

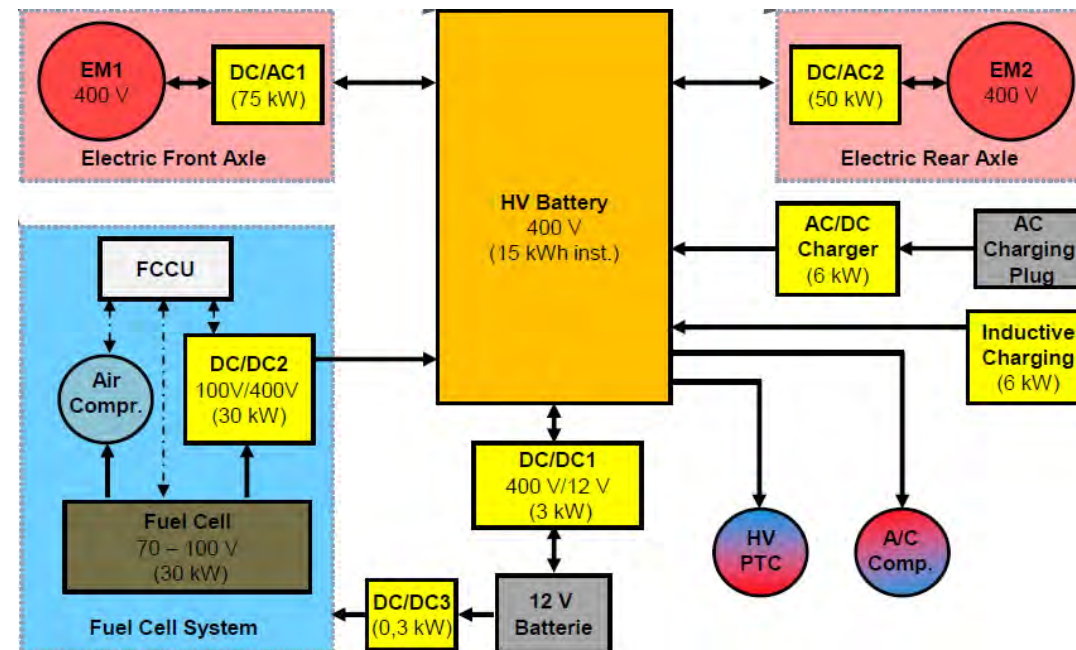

Nicola FC- Truck



- System Power 735 kW.
- 320 kWh Lithium-Ionen-Battery
- Range with one tank hydrogen 1.280 and 1.930 kilometer
- 13.000 pre-orders received
- Bosch development know-how and components involved

Source: electrive net (Branchendienst für Elektromobilität) 18.04.2019



Co-funded by the
Erasmus+ Programme
of the European Union

Nicola NZT



- E-Off-road vehicle
- Offroad-EV combines Buggy look with comfort features like sealed driver cabin with air condition and high tech operating elements
- SOP shall be 2021
- Start price 80.000 \$
- Performance 434 kW
- 4 Sec 0 - 100 km/h
- 125-kWh-Battery for a range of 240 km

Source: electrive net (Branchendienst für Elektromobilität) 18.04.2019



Co-funded by the
Erasmus+ Programme
of the European Union

Hydrogen – Infrastructure /Fuel Stations



Average fuel consumption of a FCV: **< 1 kgH₂/100km**

Players:



DAIMLER



- No. of stations in Germany (100) > target 400 by 2023
- Currently 6 stations in Austria

- Delivery to station 200 bar gaseous or liquid
- Storage pressure up to 100 Mpa
- Delivery 70 Mpa - Temperature -40°C at nozzle
- Tank time 3-5 min
- Fuel price 6- 9.-€ / kg (political price ~ ice price for the same distance)



Co-funded by the Erasmus+ Programme of the European Union

Source: O. Bishop/ Shell: "The challenges of future Mobility – Hydrogen as a solution!", A3PS Conference Oct. 2014

Fuel Cell Power Train - Conclusion



Advantages:

- no emissions (real ZEV!) – Hydrogen production from renewables
- no moving parts, less noise (except compressor!)
- high efficiency in part load condition (city traffic!)
- part of the upcoming hydrogen economy society/age
- big potential in FC- Plug-Ins

Disadvantages:

- still a bit expensive (precious materials (Pt) & catalyst metals)
- difficult to manage (especially water management)
- dynamic operation (control, i.e. humidifier)
- stability and degradation of catalyst
- starting problem (duration until ready), solved!?
- cold start problem (freezing!), solved!?
- necessity of a start / puffer battery (= battery hybrid)
- hydrogen generation & storage „on board“ or H₂- tank



FCVs – the ultimate Future?!



A few questions:

- **Give me an instant feedback on the content!**
- **What is your opinion & teaching attitude regarding hydrogen and FCVs?** Are people thinking the advanced BEV or the Hydrogen/FC Vehicle will make the race? Battery against Fuel cell or Battery + FC???
- **Hydrogen fuel path is long and the efficiency is not the best – but FCs offer long distance electric mobility without long charging** (do you think battery technology will improve quickly and overcome the shortcoming of long recharging?).
- **Are professors and students interested at all in this sophisticated topic?**
 - Are you willing to invest in labs/infrastructure that you can test fuel cells and electric powertrains?
 - Will you do fc simulations and experiments ?
- **Learning targets for students in “Fuel Cell vehicles”**
 - Get an Overview about all possible fuel cells, major component characteristics and application issues
 - Understand the different pros and cons for fuel cells and their complexity
 - Understand technical, societal and environmental impact





Engineering Knowledge Transfer Units to Increase Student's Employability and Regional Development



<https://www.facebook.com/unitederasmus/>



Co-funded by the
Erasmus+ Programme
of the European Union

This project has been funded with support from the European Commission. This publication reflects the views only of the author, and the Commission cannot be held responsible for any use which may be made of the information contained therein.
598710-EPP-1-2018-1-AT-EPPKA2-CBHE-JP

FOR EDUCATIONAL PURPOSE ONLY



Engineering Knowledge Transfer Units to Increase
Student's Employability and Regional Development

Options for a CO₂ reduced Mobility

Workshop Comparison Conclusion Discussion



Co-funded by the
Erasmus+ Programme
of the European Union

This project has been funded with support from the European Commission. This publication reflects the views only of the author, and the Commission cannot be held responsible for any use which may be made of the information contained therein.
598710-EPP-1-2018-1-AT-EPPKA2-CBHE-JP

FOR EDUCATIONAL PURPOSE ONLY

Discussed Analyses: WtW, WtT, TtW, LCA



- A **Well-to-Wheel-Analysis** (WtW) is an exact investigation of the whole chain from fuel production and transport to the supply of driving energy (in the use phase) without material production, vehicle production, maintenance and recycling.
- A **Well-to-Tank-Analysis** (WtT) focuses on the fuel production, storage and transport, up to the fuel dispenser
- A **Tank-to-Wheel-Analysis** (TtW) covers the use phase in the vehicle and is an exact investigation of energy consumption and emissions in this phase (efficiency and environ. impact)
- A **Life Cycle Analysis (LCA)** covers WtW plus material production, vehicle production, maintenance and recycling

Especially the energy consumption and the green house gas emissions are analyzed in each step!



Life Cycle Thinking – LCA (Ecobalance)



**Determination of the CO₂-
„Footprints“ in all life stations**



Co-funded by the
Erasmus+ Programme
of the European Union

LCA: production, operation (use phase) & recycling

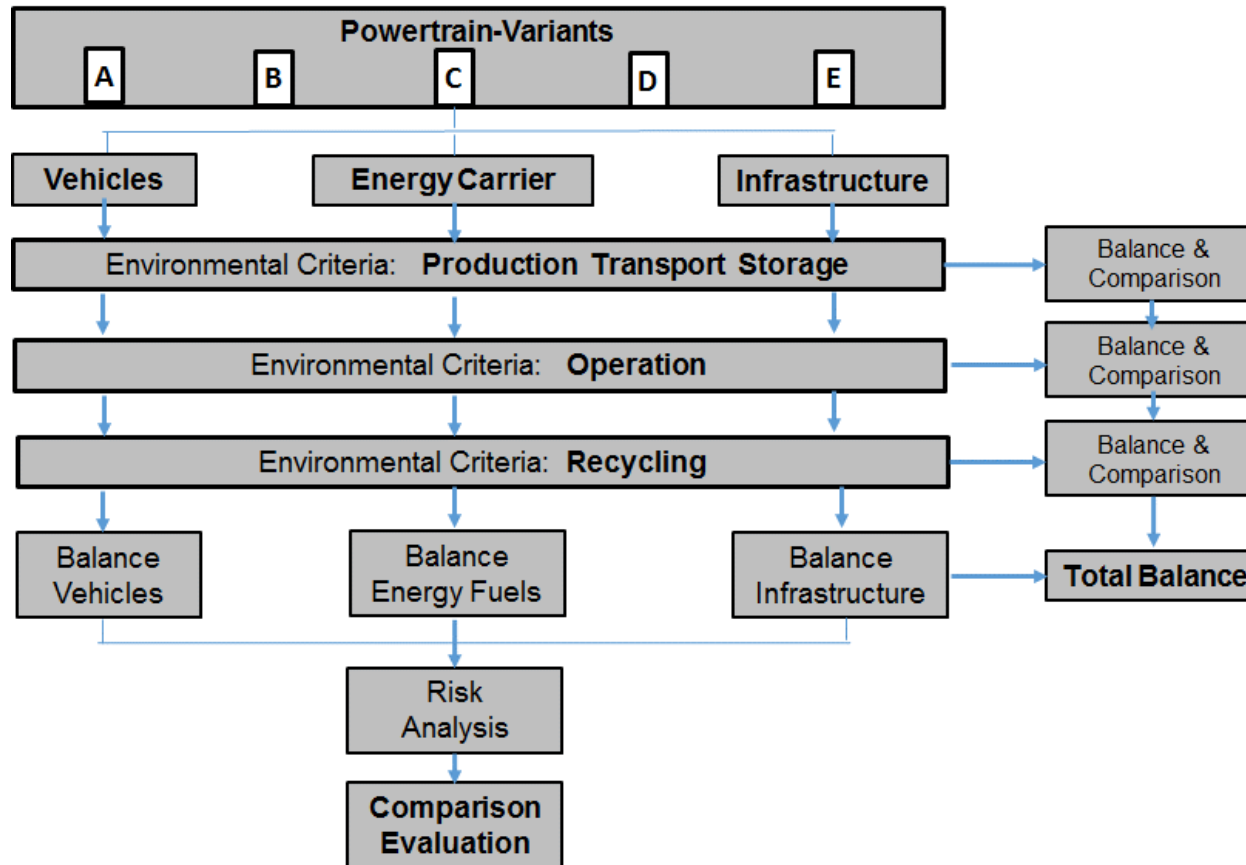

LCA covers complete vehicle life

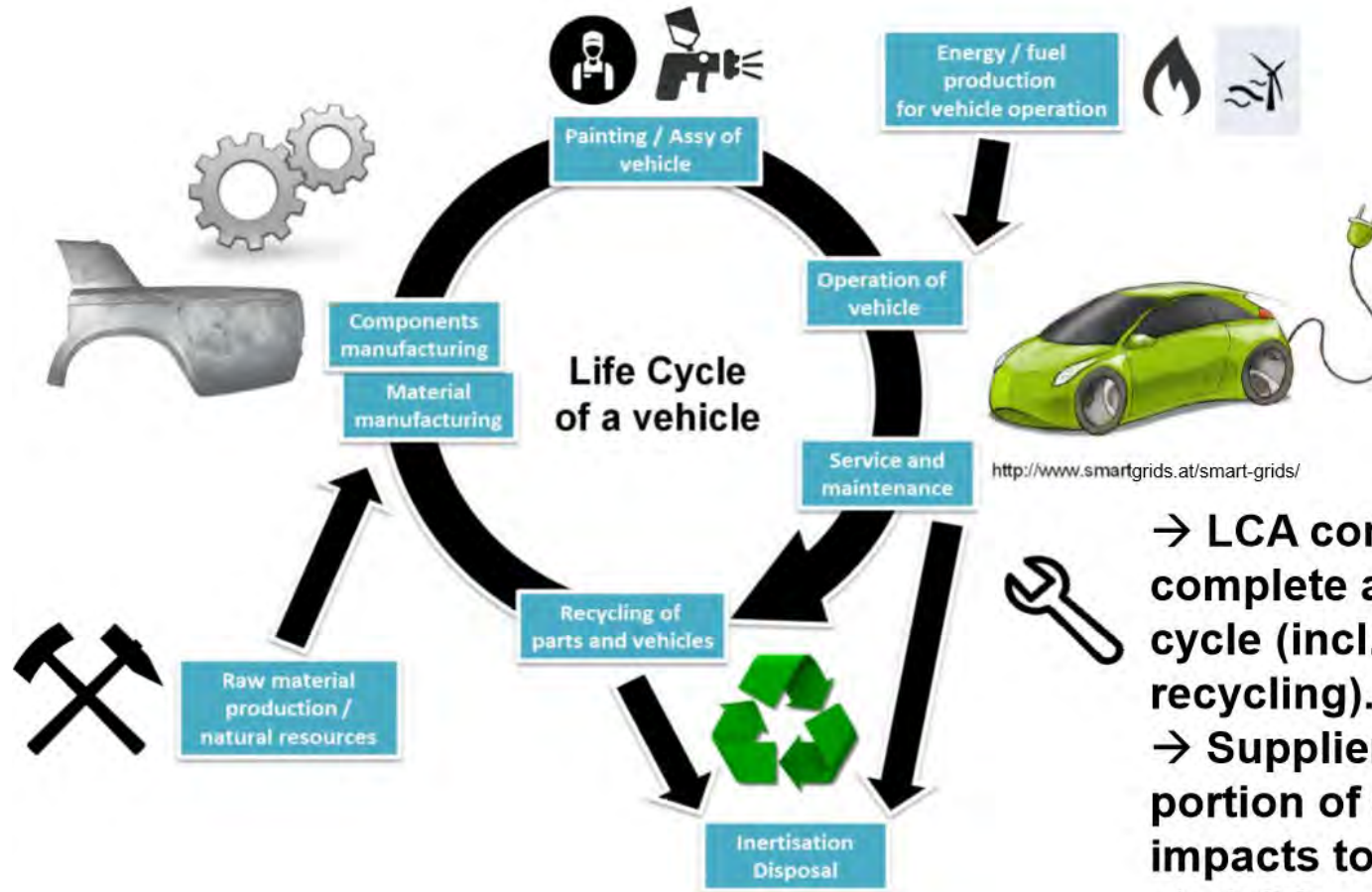

→ LCA considers complete automotive life cycle (incl. production & recycling).

→ Supplier's significant portion of environmental impacts to be estimated via LCA.

Vehicle Life Cycle environmental aspects & regulations in force (EU)

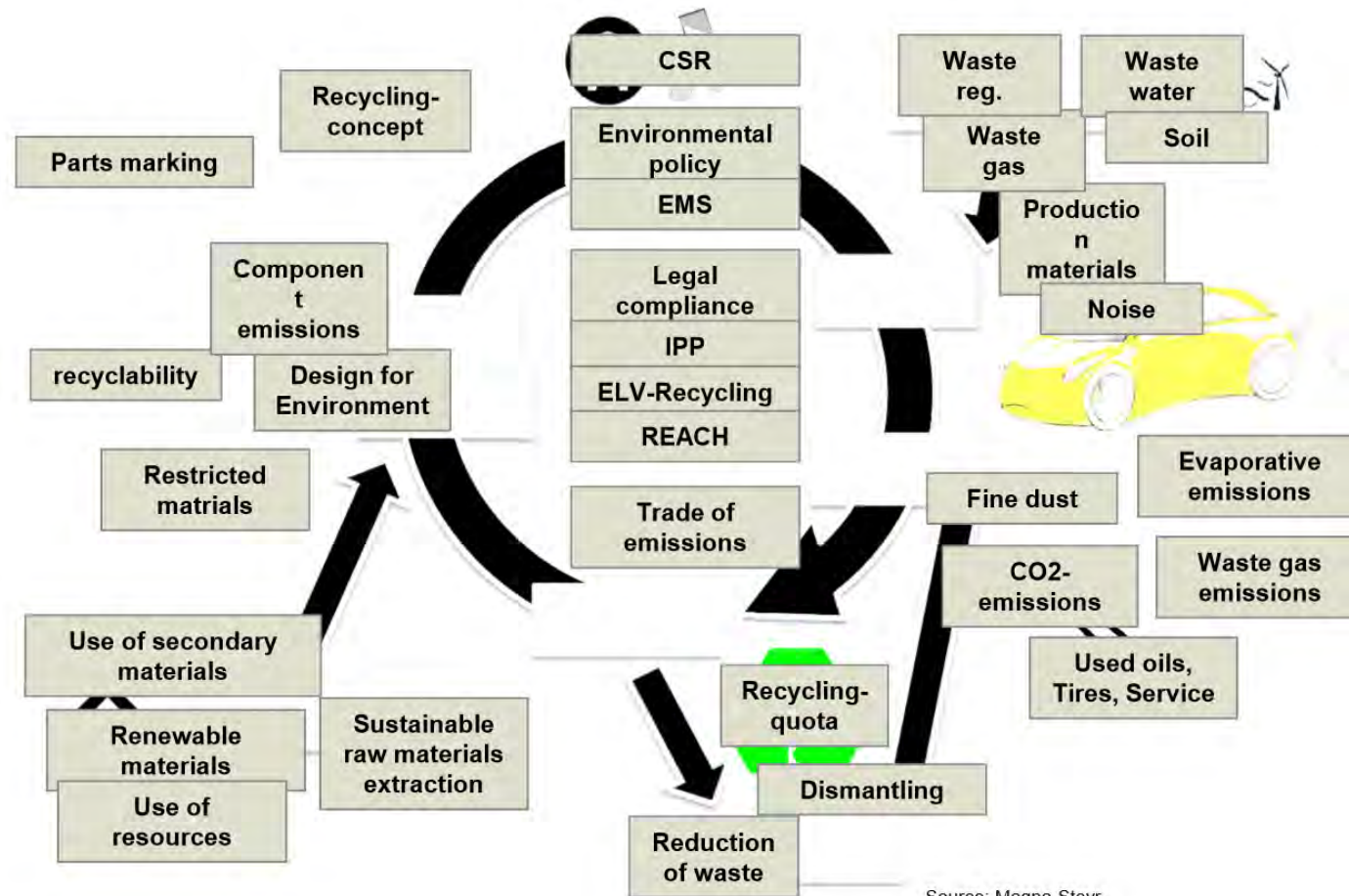

Source: Magna Steyr

Well-to-Wheel-Analyse – Conventions I



- Energy Comparison: **Gasoline eq.(univalent) [l/100km]:**

Conversion factor between gasoline and other fuels (ie. CNG, Diesel)

Example:

Natural compressed gas (CNG) is measured and sold in kg. To realize a comparison possibility to other fuels it is put in a relation to liter of gasoline. 1kg natural gas corresponds ~ 1.47l Gasoline equivalent

- Emission comparison: **Green house gas emissions [g CO₂eq.(uivalent)]**

Carbondioxid (CO₂) serves as comparison value. Especially methane (CH₄) and laughing gas (N₂O) are also considered as green house relevant gases. By this method all known contributions can be added and compared.

Example:

Methane is 21 times worse in regards green house effect than CO₂, ie. 1 kg Methane corresponds a CO₂-equivalent of 21 kg!



Well-to-Tank-Analysis - Conventions II



- **Fuel „Path“**

Well to Tank describes the production process as well as the storage, transport of the fuel from oil well to the dispenser nozzle.

Example: for the comparison of vehicle concepts different paths of fuels have to be evaluated:

Fuel Hydrogen:

- Fuel condition:

- Liquid hydrogen in cryogenic-tank at -253° Celsius (“LH”)
- Compressed gaseous hydrogen in pressure tank 700 bars (“CH”)

- Fuel (hydrogen) production:

- by electrolysis (electricity used with EU production mix)
- out of NG (natural gas) by steam reforming, average transport distance of gas from near eastern gas fields with pipelines of 4000 km (pipeline 4000 km)

Fuel path CNG (compressed natural gas)

- Fuel origin:

- Average transport distance from near eastern gas fields, pipeline length 4000 km (pipeline 4000 km)
- European source (i.e, Norwegian fields et. al. acc. EU Mix)



Total carbon footprint of an average car

Green house gas (GHG) emissions (metric ton CO₂-equivalents)

**Total Σ 60 ton GHG
per vehicle**

(150.000mls, 200Wh/km, US LV Mix)

Powermix US LV

(low voltage consumer mix):

0,66 kg CO₂-Eq/kWh

GWP100a // CML2001, IPCC2007

Base data from Ecoinvent V3.1

Specific data by Magna Mila vehicles

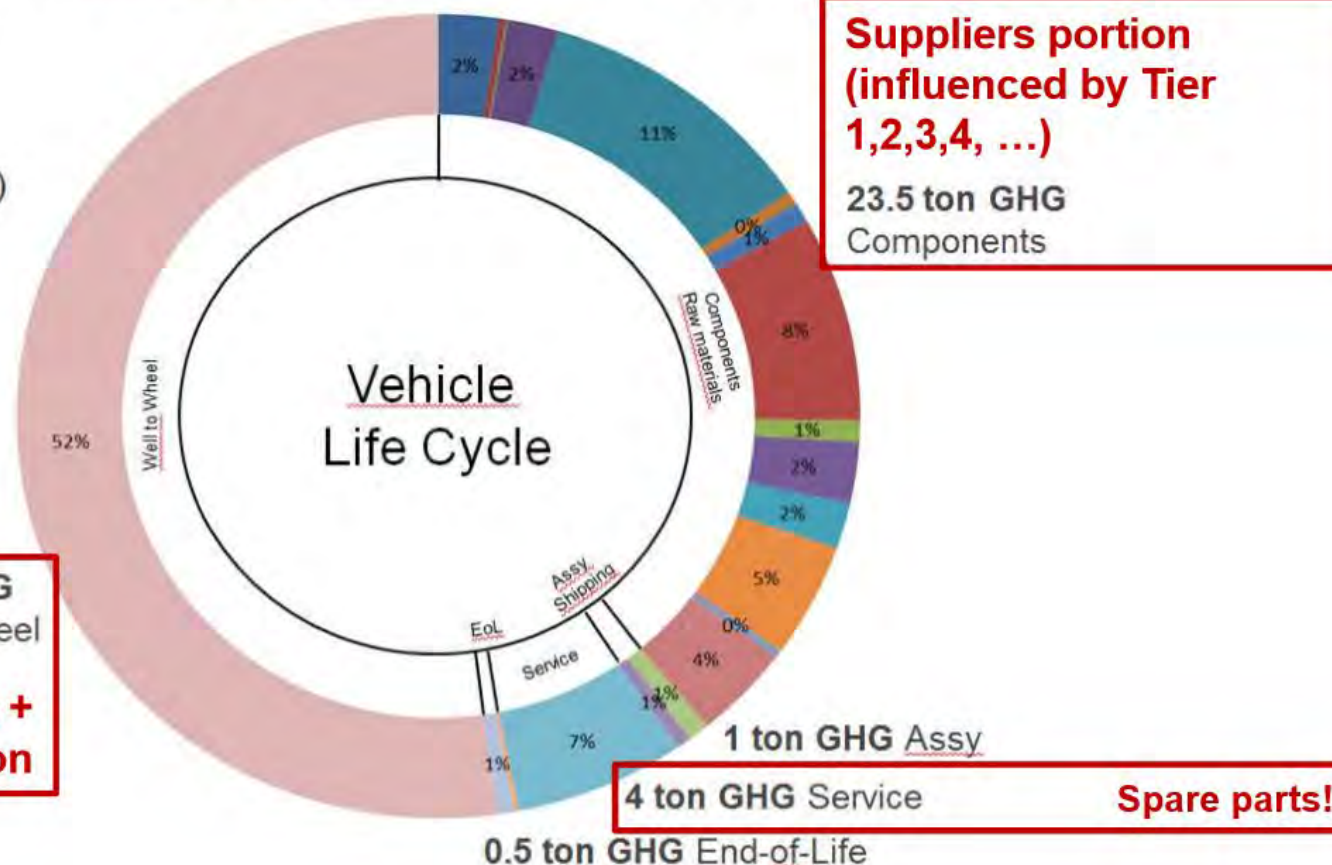

**Suppliers portion
(influenced by Tier
1,2,3,4, ...)**
23.5 ton GHG
Components

**31 ton GHG
Well to Wheel**
**Car makers portion +
Fuel/energy producers portion**

1 ton GHG Assy
4 ton GHG Service
0.5 ton GHG End-of-Life
Spare parts!

Which Powertrain will win the race?

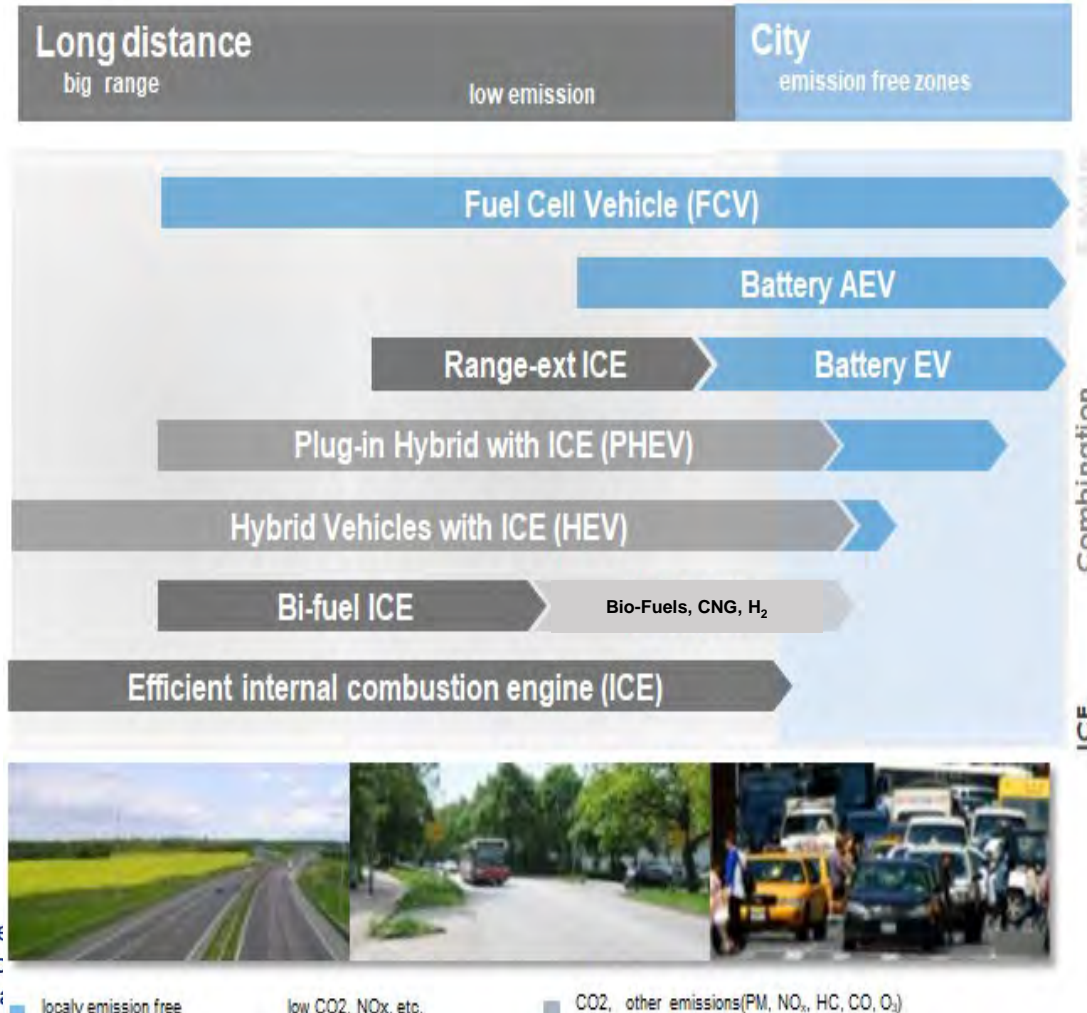

Diversification of powertrains and fuels to fulfil CO₂ legislation

Advanced powertrains

- High Engineering demand
- New Components & Systems
- Electrification needs new **battery systems with high energy density**
- CNG and hydrogen needs new infrastructure and **high pressure gaseous storages**

Future powertrain concepts in comparison

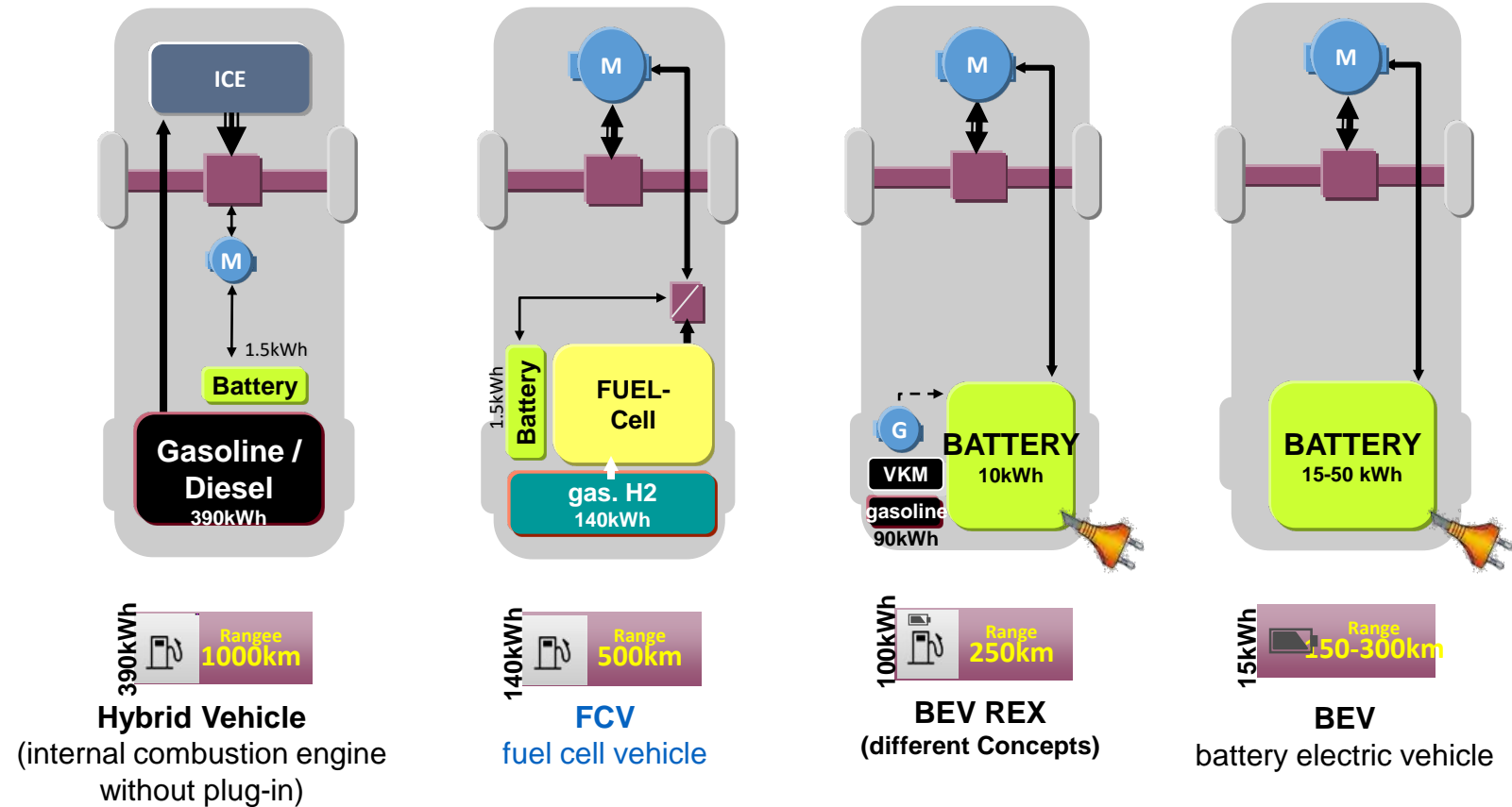

When is transition to electrified powertrain meaningful?

BEV and environment (old data from the 1990s):

CO₂ emissions of BEVs considering primary energy consumption:

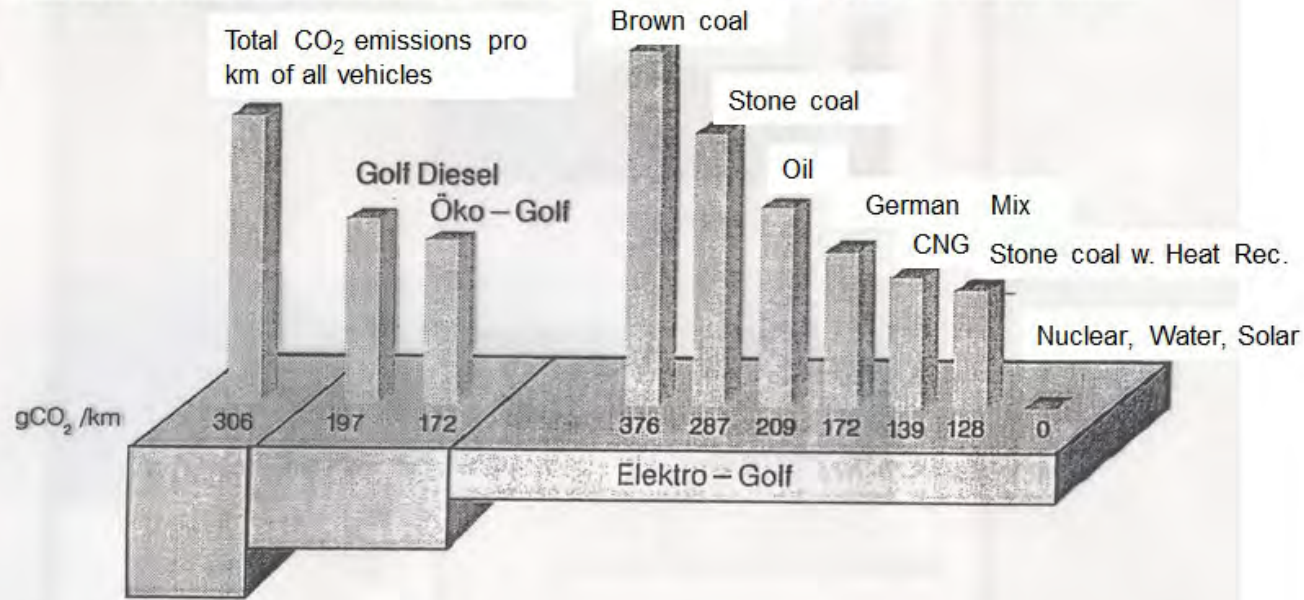

 **VOLKSWAGEN**

Konzernforsch.

The answer depends strongly on the local situation!

Today: BEV – with Euro-Mix CO₂ = ~ 80 g/km !

Germany succeeded in an CO₂ increase by stopping nuclear power and discriminating diesel engines!

CO₂ Comparison of powertrains - Potentials

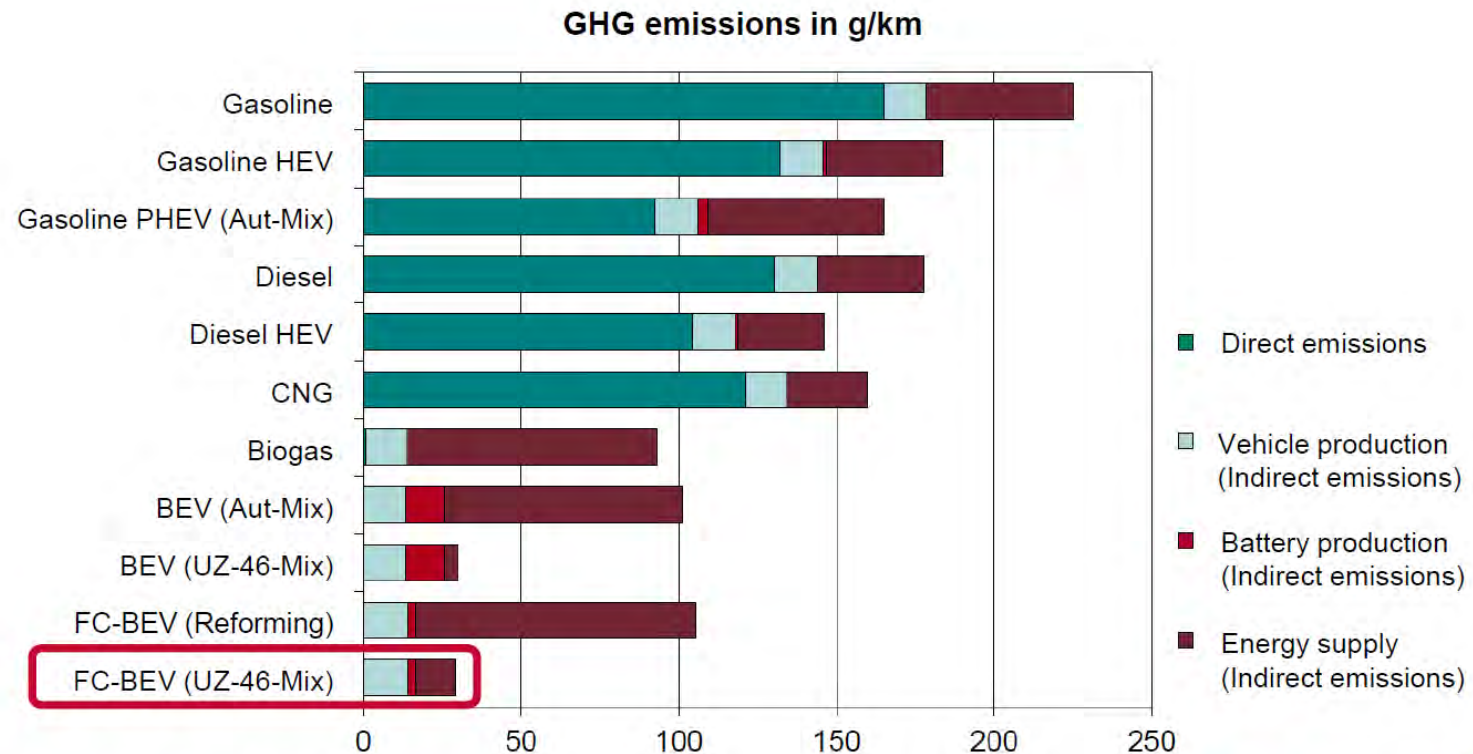

Source: Umweltbundesamt (2017)

umweltbundesamt⁰



Co-funded by the
Erasmus+ Programme
of the European Union

CO₂ Comparison of powertrains - Potentials

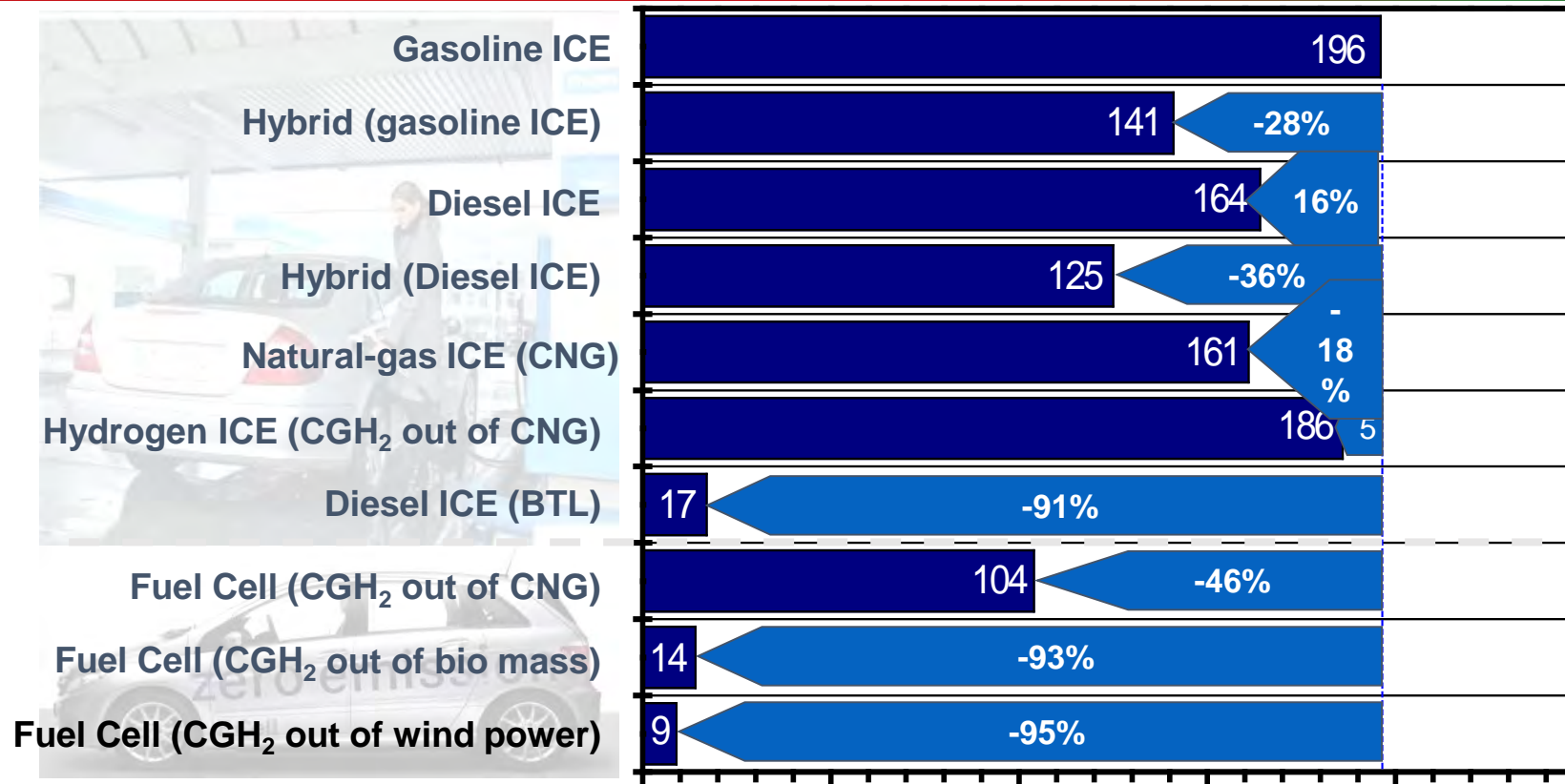

Reference: Compact sedan, NEDC

Source: EUCAR/CONCAWE/JRC, 2005



Co-funded by the
Erasmus+ Programme
of the European Union

Efficiency of vehicles in comparison

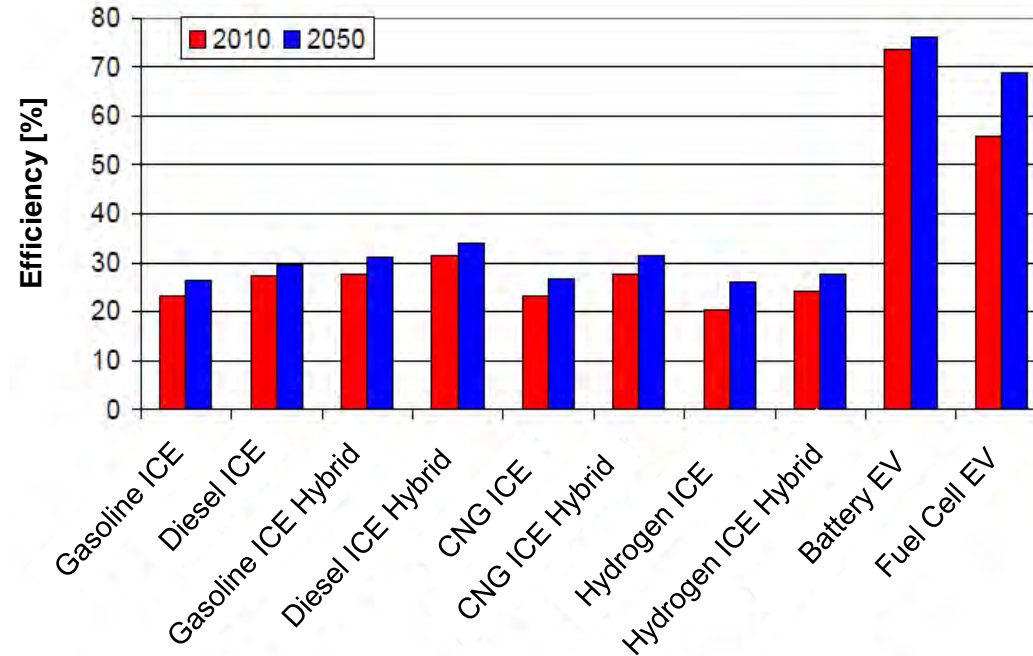

Source: Altankra Study, 2008 Techn. University Vienna/JR/AVL

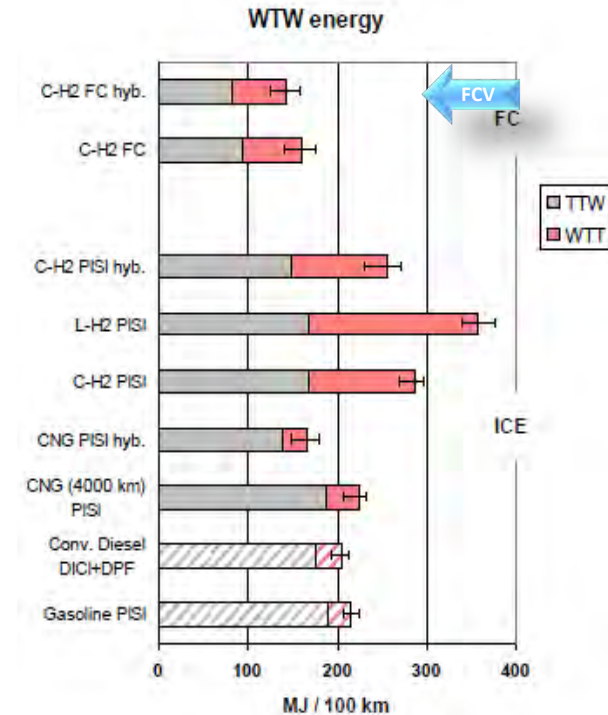

Source: Well-to-Wheel Report Concawe/Eucar/EC 2007

Data from WTW Report :

Gaseous Hydrogen produced by steam reforming at site incl. 4000km long pipeline; Passenger car comfort class
 Energy for FC-Vehicle: **0.837 MJ/km**, eta=53%
 Comp. with Diesel car: **1.77MJ/km**, eta=25%



Diesel passenger car consume double the energy compared to FCVs!
Total efficiency of 60% has been achieved!

Effect of lightweight design in vehicles accumulated over the complete life

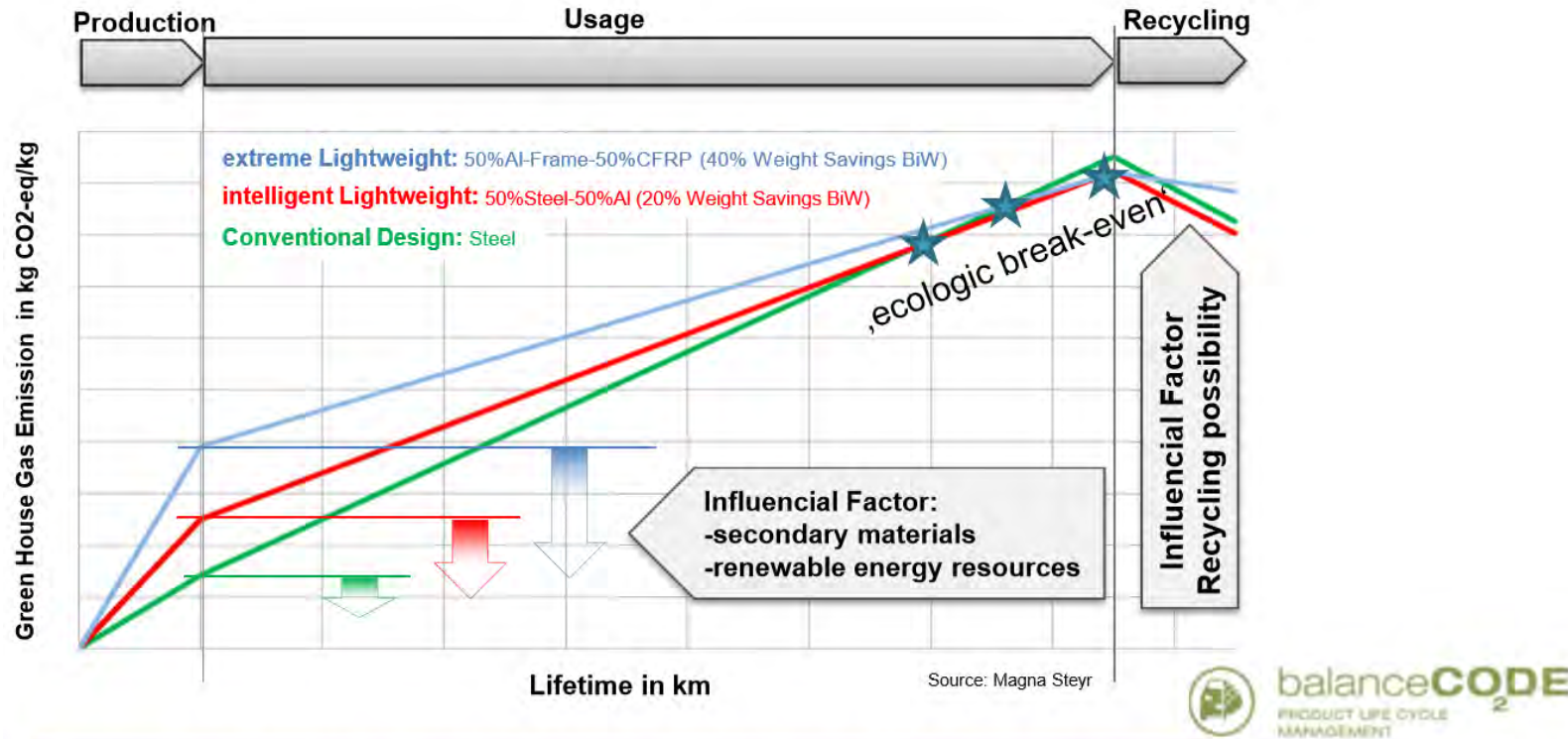

Best ecologic solution has to be investigated via LCA of entire life cycle!

Source: Jungmaier, Joanneum Research Graz

Well to wheel considerations – Energy & CO₂ emissions

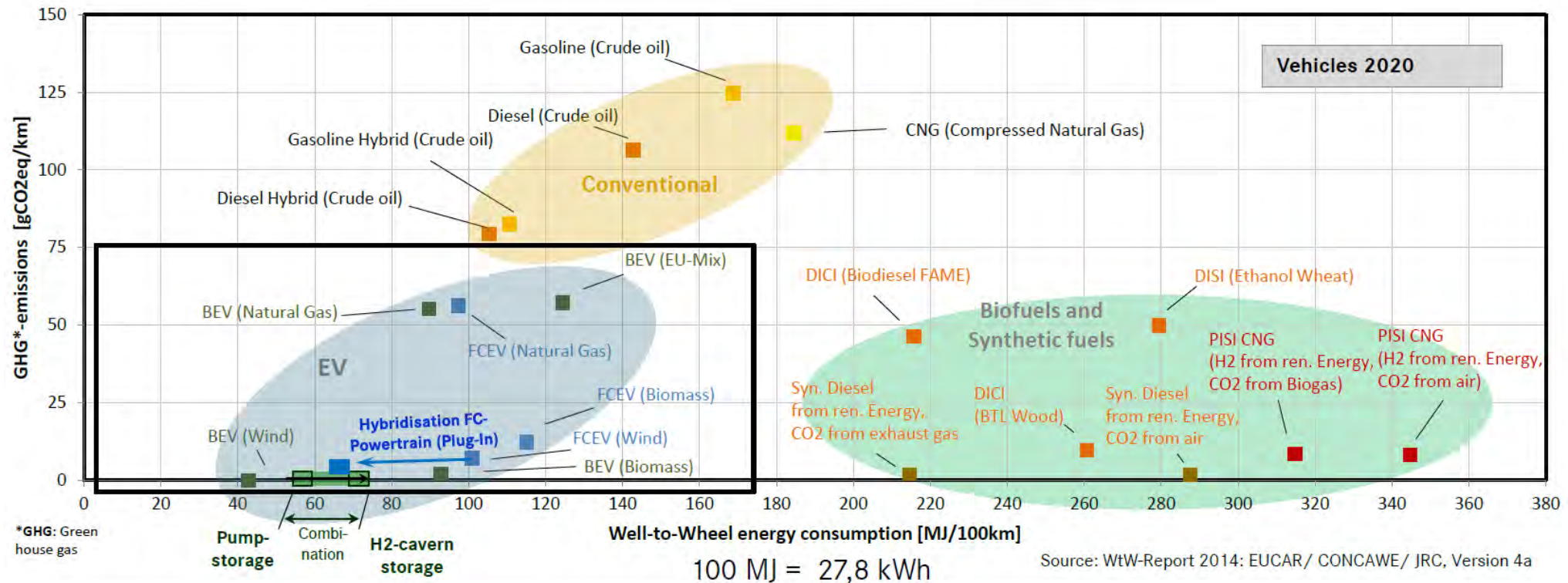

Well to wheel considerations – Energy & CO₂ emissions

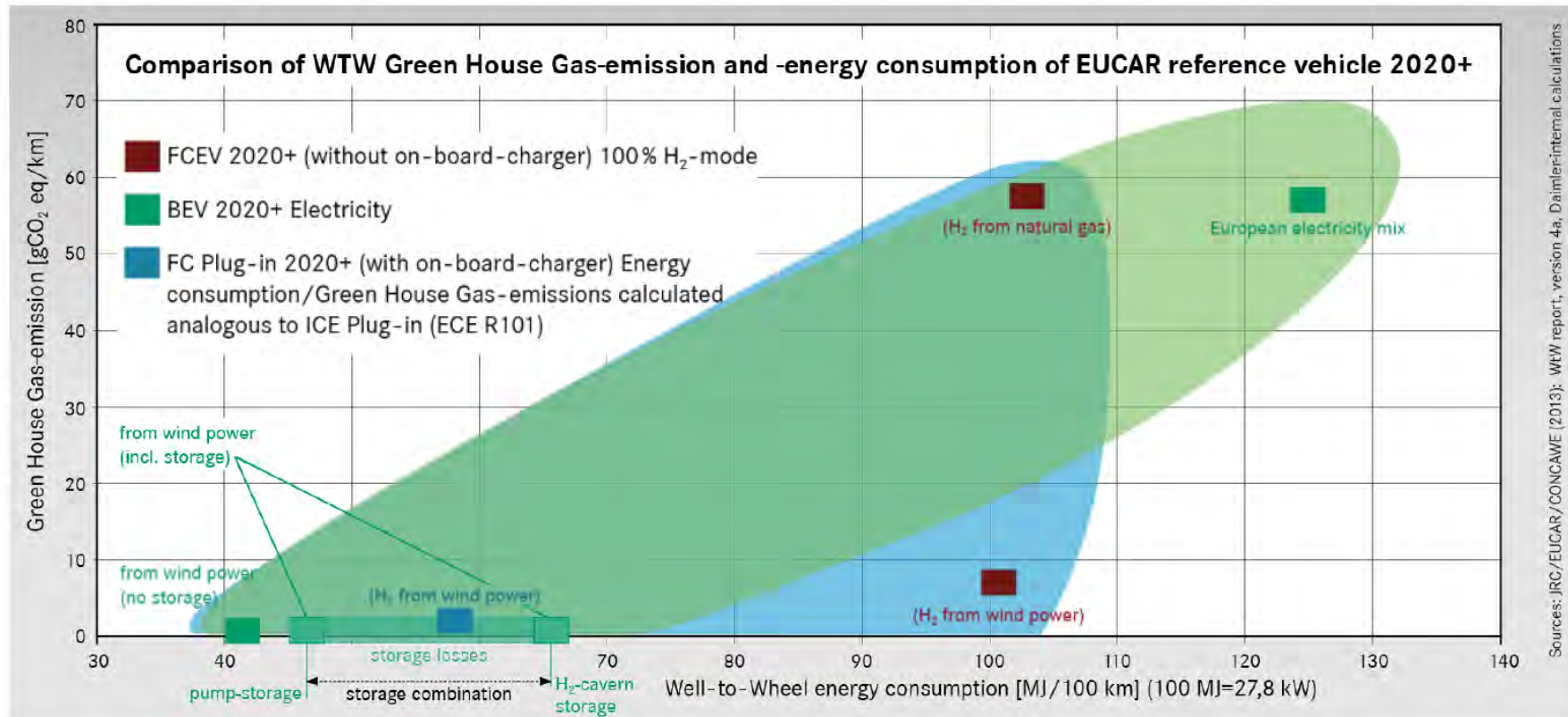

Well to wheel considerations – Energy & CO₂ emissions

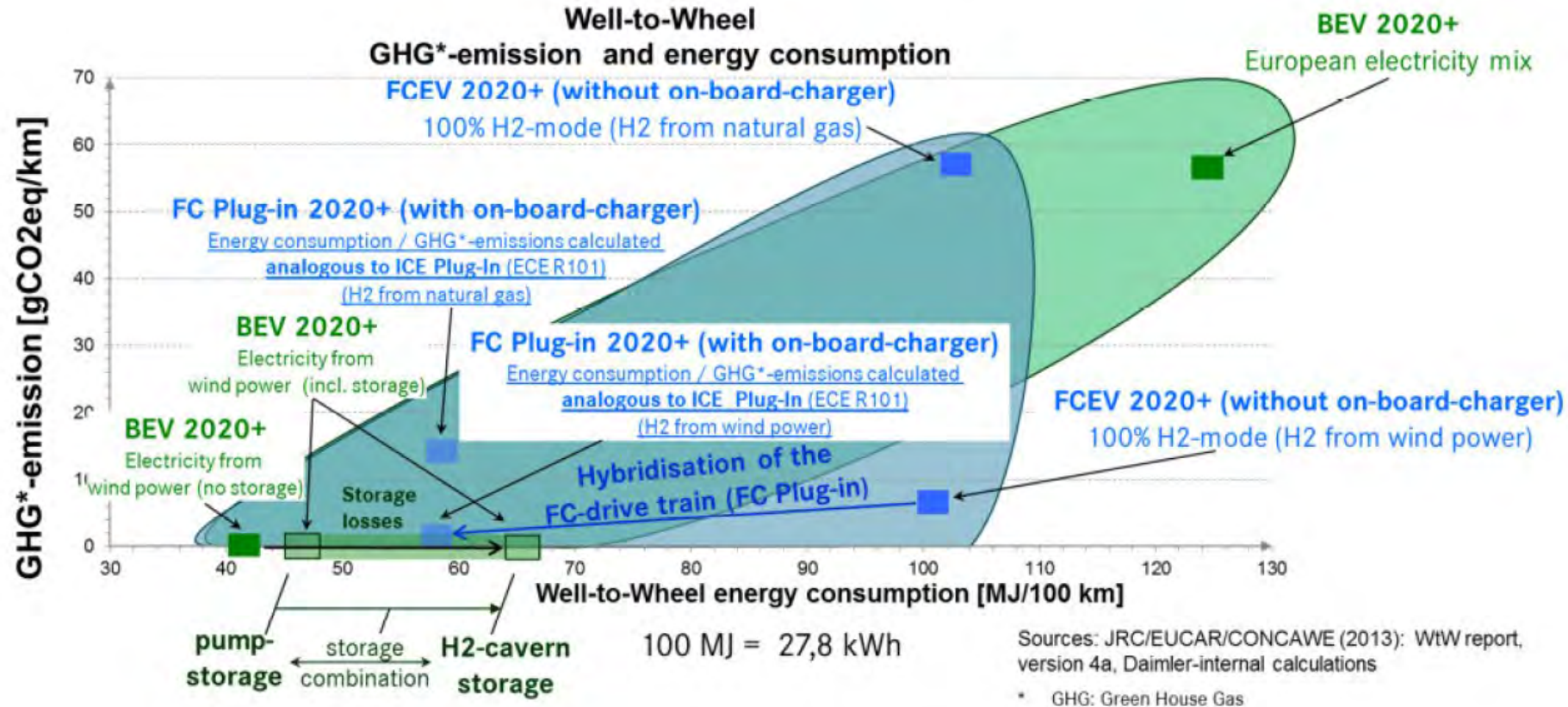

Co-funded by the Erasmus+ Programme of the European Union

ICE (gasoline/Diesel), BEV, FCV

GHG Emission Comparison over lifetime



Cumulated GHG Emissions of Passenger Vehicles with Different Fuels

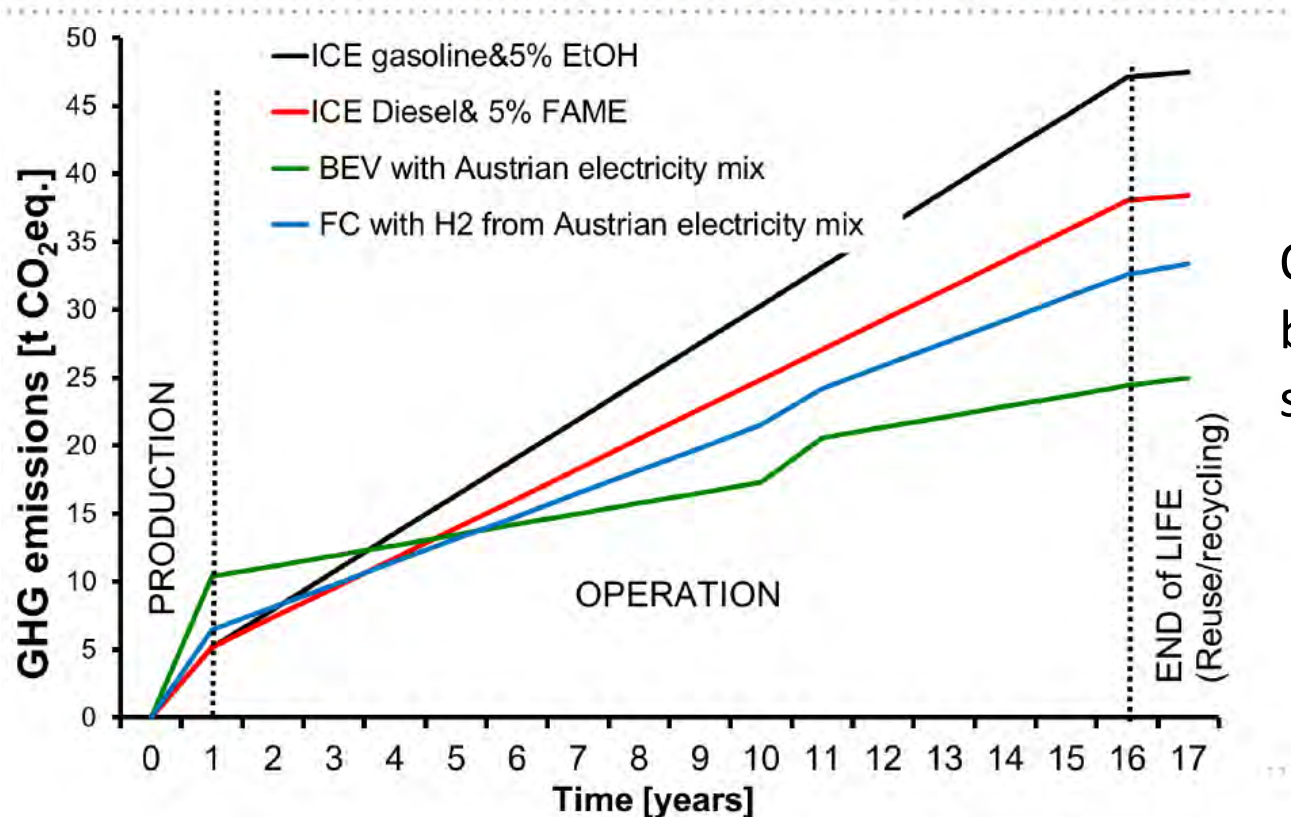

Only after 3-5 years the BEV becomes better than a standard diesel vehicle!!!

Conclusion on Powertrain and Fuel Comparisons



Target:

Continued process for improving air quality especially in areas which suffer from high density of traffic and need CO₂ (poor?)-free mobility without range limitation;

“Zero environmental impact!”

- EVs followed by fuel cell electric powertrains with **electricity produced by renewable sources** seem to have the best CO₂ footprint and the lowest energy demand
- Bio-fuel and synthetic fuels can have very low carbon footprints too, but need more than double the energy for their production – their economical viability is doubtful (??)
- Most likely in the future alternative powertrains will coexist and their spread will be dictated by the local (energy-)situation and local availability of fuels or feedstock (??)
- OEMs will have to cope with that situation and provide the full spectrum of variants (??)



Future of advanced powertrains ?



The future of advanced powertrains depends on:

- How important and serious are we taking ZERO-Emission? Will we/Can we achieve the Climate Goals?!
- Battery technology evolution and cost development
- Improvement potentials for emission reduction and efficiency improvements of conventional powertrains particular in Hybrid applications
- Affordable introduction of (PHEV-) hybrid-technology in basically conventional vehicles in high numbers
- How quick an introduction of a hydrogen economy can be introduced > base for hydrogen/fuel-cell vehicles
- Can we achieve a global understanding on sustainability and necessity for a change in Mobility (??)



CO₂ reduced (free) Mobility – Prerequisite

- A prerequisite for CO₂ reduced or free Mobility is the **linkage of Energy- and Mobility Change!**

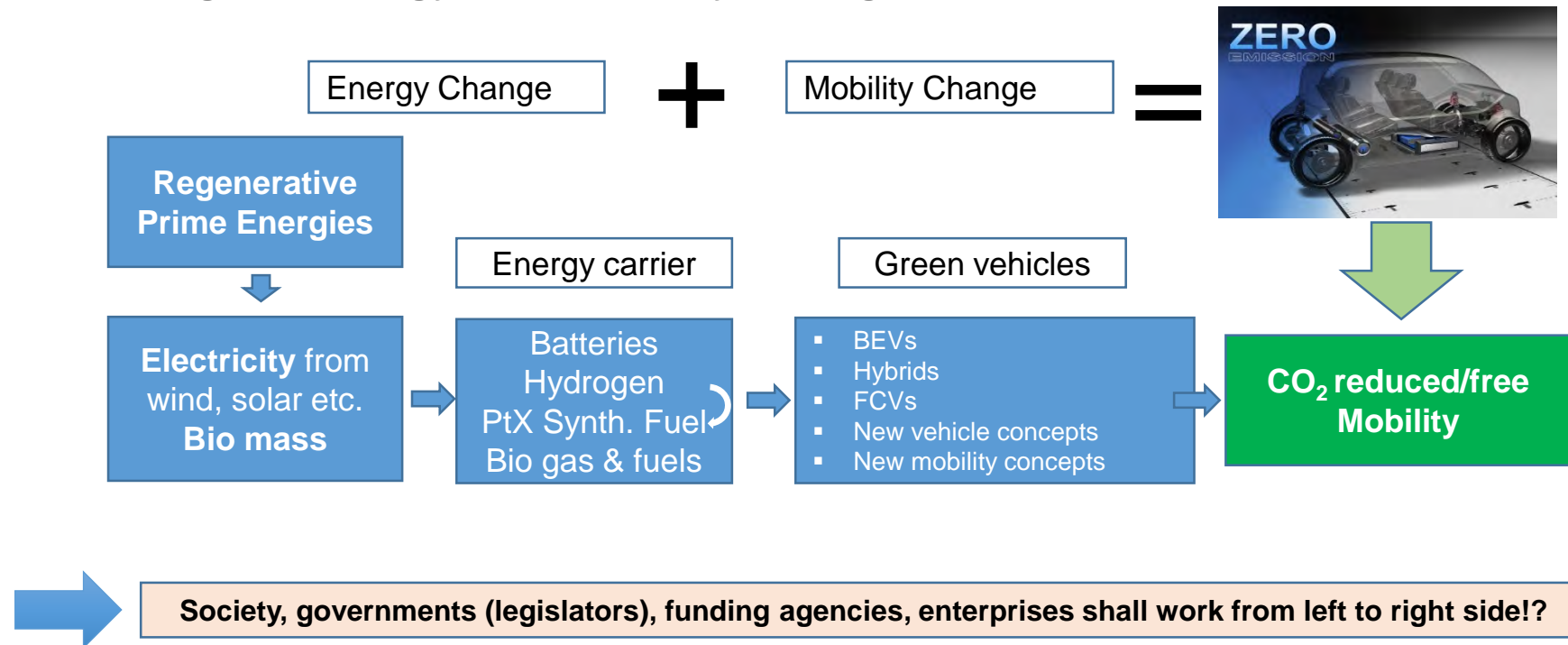

Workshop 0



Procedure:

- Each university elects a “Speaker”!
- Questions sheets are displayed at the canvas
- Discuss the answers with your team members (approximately 5 to 10 minutes)
- The speakers one by one present their answers and let the audience discuss it.
- The major common findings are being noted and added to the MoMs
- Repeat the procedure with the next question sheet. Three questions sheets are prepared



Workshop – Questions I



Environmental Awareness in South East Asia:

- Are the government/countries in SE Asia just following the global trends (with a reasonable time delay)?
- Are there any signs of an “energy change” to renewables in your country?
- For individual mobility: are they overtaking the CO₂ and emission legislation from EU, JP or US??
- Is there any chance for an individual way of Malaysia, Indonesia, etc ?? (more progressive or moderate?)
- Are people informed about global warming and the consequences in your region?
- Are the government doing any measures to reduce CO₂ in your countries (not only mobility)?
- How do you think about the “panic” mood in Europe spread out by Greta Thunberg and her followers about global warming – do you agree or do you think it is exaggerated, hyperbolized and too much wind about nothing???
- Could you imagine that young people in your country go to the streets for protest as well??



Workshop – Questions II



Mobility Behaviour in South East Asia:

- Find out what are the differences compared to Europe?
- Is the climate “preventing” sustainable modes of mobility?
- Are there Cities in SE Asia of short distances? (remember Thorsten 1st day)
- Do municipalities enough to reduce the need of mobility (city planning, planning of public transport)?
- Is it possible in your cities to bring living place and workplace together?
- Are people flexible enough to follow work place or long commuting is common & increasing?
- How is the attitude of young people? Are they eager to have their own car for individual mobility, or are they preferring “digital mobility”???
- Give a short assessment on the status of public transport in your country – is it a reasonable alternative to individual transport or not??
- Can SE Asia countries learn from outside and avoid mistakes done abroad (i.e. US or Europe)



Workshop – Questions III



Powertrain Technologies in South East Asia:

- Which “fuel” resources are available and should be used in future (in the next 20 years) in your country??
- Do you see potential for renewable sources like solar, wind, hydro-power and other bio sources (additional to palm oil)?
- Which additional and reasonable infra-structures can be build up realistically?
- Finally which car technology will fit best for South East Asia and your country? EVs (cars and scooters), Hybrids, Fuel cell cars??





Engineering Knowledge Transfer Units to Increase Student's Employability and Regional Development



<https://www.facebook.com/unitederasmus/>



Co-funded by the
Erasmus+ Programme
of the European Union

This project has been funded with support from the European Commission. This publication reflects the views only of the author, and the Commission cannot be held responsible for any use which may be made of the information contained therein.
598710-EPP-1-2018-1-AT-EPPKA2-CBHE-JP

FOR EDUCATIONAL PURPOSE ONLY